

This manual is a living document that will be updated frequently.  
Please visit [www.moogmusic.com/moogone](http://www.moogmusic.com/moogone) to find the most up to date manual. If you are having trouble finding specific information about your Moog One in this manual please email: [moogonemanual@moogmusic.com](mailto:moogonemanual@moogmusic.com) for assistance.

**THIS VERSION WAS PUBLISHED ON 1/10/19.**

Revisions made to:  
Page 52 - Spread Parameter  
Page 100 - Stereo Width  
Page 129 - Noise Reduction

**one**

“Musical instruments provide  
the most efficient and refined  
interface between human and  
machine of anything we know.”

**- Dr. Robert Moog -**

## IMPORTANT SAFETY INSTRUCTIONS

**WARNING - PLEASE BE ADVISED THAT THIS INSTRUMENT WEIGHS 45 POUNDS, AS SUCH WE RECOMMEND THAT TWO PEOPLE REMOVE THE INSTRUMENT FROM THE BOX AS A SAFETY PRECAUTION. PLEASE DON'T ATTEMPT TO MOVE THE INSTRUMENT BY YOURSELF.**

**WARNING - WHEN USING ELECTRIC PRODUCTS, THESE BASIC PRECAUTIONS SHOULD ALWAYS BE FOLLOWED.**

1. Read all the instructions before using the product.
2. Do not use this product near water - for example, near a bathtub, washbowl, kitchen sink, in a wet basement, or near a swimming pool or the like.
3. This product, in combination with an amplifier and headphones or speakers, may be capable of producing sound levels that could cause permanent hearing loss. Do not operate for a long period of time at a high volume level or at a level that is uncomfortable.
4. The product should be located so that its location does not interfere with its proper ventilation.
5. The product should be located away from heat sources such as radiators, heat registers, or other products that produce heat. No naked flame sources (such as candles, lighters, etc.) should be placed near this product. Do not operate in direct sunlight.
6. The product should be connected to a power supply only of the type described in the operating instructions or as marked on the product.
7. The power supply cord of the product should be unplugged from the outlet when left unused for a long period of time or during lightning storms.
8. Care should be taken so that objects do not fall and liquids are not spilled into the enclosure through openings.

*There are no user serviceable parts inside. Refer all servicing to qualified personnel only.*

**NOTE:** This equipment has been tested and found to comply with the limits for a Class B digital device, pursuant to part 15 of the FCC Rules. These limits are designed to provide reasonable protection against harmful interference in a residential installation. This equipment generates, uses and can radiate radio frequency energy and, if not installed and used in accordance with the instructions, may cause harmful interference to radio communications. However, there is no guarantee that interference will not occur in a particular installation. If this equipment does cause harmful interference to radio or television reception, which can be determined by turning the equipment off and on, the user is encouraged to try to correct the interference by one or more of the following measures:

- Reorient or relocate the receiving antenna.
- Increase the separation between the equipment and receiver.
- Connect the equipment to an outlet on a circuit different from that to which the receiver is connected.
- Consult the dealer or an experienced radio/TV technician for help.

**CAUTION:** Please note that any changes or modifications made to this product not expressly approved by Moog Music Inc. could void the user's authority granted by the FCC to operate the equipment.

# TABLE OF CONTENTS

## 07 UNPACKING AND INSPECTION

## 07 SETUP AND CONNECTIONS

## 08 MOOG ONE OVERVIEW

09 Presets, Synths, And Performance Sets

09 Voice Architecture

## 10 PILOTING MOOG ONE

10 Front Panel

17 Keyboard And Left Hand Controller

19 Rear Panel

## 22 MOOG ONE MODULES

22 Oscillators

29 Noise

31 Mixer

33 Filters

40 Envelopes

46 Low Frequency Oscillators

51 VCA

53 Output

57 Performance Set

61 Master Clock

63 Voice Allocation (Hold/Chord/Polyphony)

67 Modulation

78 Arpeggiator

82 Sequencer

96 Effects

112 Left Hand Controller

## 118 THE BROWSER

119 Loading A Preset

119 Loading A Timbre

120 Saving Presets And Synth Timbres

## 122 EDITING AND SAVING

122 Compare

122 Snapshot

123 Autosave

## 124 SETTINGS

124 Global

129 MIDI Control

132 CV Inputs

133 CV Outputs

134 Utilities

135 Library

140 Tuning

## 141 SPECIFICATIONS

## 143 SERVICE AND SUPPORT

*This page left intentionally blank*

## UNPACKING AND INSPECTION

Use caution when unpacking your new Moog One, and be sure that nothing is lost or damaged. Moog recommends saving the carton and all packing materials in case you ever need to ship the instrument for any reason.

### CONTENTS

In addition to the instrument itself, your new Moog One also ships with the following items:

1. Power adapter and connecting power cord
2. Owner's Manual
3. Registration Card

### SETUP AND CONNECTIONS

Before you begin exploring your Moog One, you will need to provide the instrument with power, and connect it to an audio monitoring system so that you can hear it.

### WHAT YOU WILL NEED

1. A stand or table capable of supporting Moog One (which weighs about 45 lbs.)
2. A properly wired and grounded AC outlet
3. Two 1/4" balanced TRS to TRS or TRS to XLR cables for connecting Moog One to an audio monitoring system, or stereo headphones outfitted with a 1/4" TRS (Tip/Ring/Sleeve) plug may be used in either of the front Headphone jacks.

**NOTE:** *Moog One is equipped with balanced outputs, so use either 1/4" TRS to 1/4" TRS cables or 1/4" TRS to XLR cables for the best results. Unbalanced 1/4" TS to 1/4" TS instrument cables may also be used, but are not recommended.*

### CONNECTING THE POWER SUPPLY

Moog One uses a universal power supply that can accommodate AC power sources ranging from 100 to 240 volts, and either 50 or 60 cycles (Hz). The included power supply features a detachable IEC-style power cable.

1. Connect the included IEC power cable to the Moog One power supply.
2. Connect the power supply cable to the 19-volt DC locking connector on the rear panel of Moog One.
3. Connect the other end of the power cable to a suitable AC wall outlet with a protective earth ground connection.
4. Finally, use the power switch on the rear panel to turn on your new Moog One.

**NOTE:** *The power supply connects to your Moog One using a locking connector. To release this connector from the instrument, simply press the locking tab at the base of the connector and gently slide out the connector plug. Never pull on the cable, only the plug.*

### AUDIO MONITORING

With the Moog One **MASTER VOLUME** knob turned all the way down, connect one 1/4" cable to the **MAIN L** output, and the other 1/4" cable to the **MAIN R** output, then connect the opposite ends to a pair of L/R inputs on an amplified speaker system or mixing console. Adjust the Moog One volume level by slowly turning the **MASTER VOLUME** knob clockwise while playing the keyboard.

If you're using headphones, turn the **HEADPHONES** knob all the way down before plugging them into either of the two headphone jacks (located on the front edge of the Left Hand Controller panel). Adjust the volume level by slowly turning the **HEADPHONES** knob clockwise while playing the keyboard.

**NOTE:** *It may take up to 5 minutes for Moog One to warm up before Oscillator tuning has stabilized, especially if it has been outside in a car on a cold night. (Although its Oscillators are very stable, Moog One is an analog synthesizer, after all.)*

## **MOOG ONE**

Designed to exceed every expectation, Moog One is the first polyphonic instrument from Moog in decades. From the original napkin sketches to the day we boxed the first unit for shipment from the Moog Factory here in Asheville, North Carolina, the goal has remained to create an analog, polyphonic, programmable, and multitimbral synthesizer that is without equal. Realizing the Moog One vision has been a journey of collaboration and discovery; a sharing of ideas between the Moog Team and countless artists, sound designers, and synthesizer enthusiasts from around the globe. In crafting Moog One, it was paramount to keep the interface intuitive and tactile. The hope is that your sonic explorations will transcend the separation of artist and instrument, allowing Moog One to be the conduit for your own creative voice.

Moog One is an analog, polyphonic, programmable, and multitimbral synthesizer; each of these terms carries its own significance and its own legacy.

### **ANALOG**

The heart of the Moog One sound is its analog signal path. Since the development of the first Moog Synthesizer in 1963, Moog analog circuits have been renowned for their rich harmonic qualities and for the organic nature of their expression.

### **POLYPHONIC**

Synthesizers changed forever with the advent of polyphony. As a polyphonic synthesizer, Moog One can independently articulate numerous voices simultaneously; up to 8 or 16, depending on the configuration of your instrument. This voice-count designation is stamped on the serial number label on the underside of your Moog One.

### **PROGRAMMABLE**

Moog One is a wonderland for sound designers and tweekers, with a Front Panel hosting over two hundred knobs and buttons. The status of each knob and button – plus countless below-the-surface parameter settings – are stored and saved in memory in near limitless numbers of Presets. Find your favorites using the searchable Browser. These saved Presets can also be assigned to the Front Panel's Performance Set for instant recall.

### **MULTITIMBRAL**

As a three-part multitimbral instrument, Moog One is capable of playing up to three distinct Synths simultaneously – split, layered, or zoned across the keyboard – all from within a single Preset. With each Synth able to access its own sound parameters, note range, arpeggiator, and sequencer, Moog One can create its own ensemble performances or deliver a richly layered arsenal of sound.



## OVERVIEW

By design, Moog One is both intuitive and efficient. The iconic angled Front Panel groups single-function knobs together by module – Oscillators, Filters, Envelopes, LFOs, etc. – in a way that is reminiscent of the original Moog modular synthesizers, as well as the legendary Minimoog Model D. Under the hood, a robust operating system keeps track of voice assignments, modulation routings, and other housekeeping tasks. The interactive LCD center panel provides quick access to global settings and reveals a second level of sound-creation parameters via the **MORE** button located in the top right corner of most modules. This fluid combination of hands-on control and precision parameter editing establish Moog One as both a powerful performance instrument and a serious sound-design station.

And, of course, there's more. Moog One provides 61 expressive keys that respond to both velocity and aftertouch. The enhanced Left Hand Controller (LHC) features a unique three-axis touchpad, and a pair of aluminum pitch and modulation wheels. Two control pedal inputs and a sustain pedal jack offer further opportunities for real-time expression. Onboard sequencing, arpeggiating, and effects processing – including premier reverbs from Eventide® – add depth and motion to your sonic creations. Best of all, Moog One can communicate with your other gear via MIDI, USB, and through analog Control Voltage (CV) inputs and outputs. Finally, Moog One encourages you to dive deeply into the world of music synthesis with a programmable Matrix Modulation page connecting dozens of modulation sources and destinations – in various amounts – using a virtual patchbay. Purists can even bypass the entire digital Effects section to achieve a 100% analog audio path - from the Oscillators, Filters, and Amplifier, to the final analog output jacks.

## PRESETS, SYNTHS, AND PERFORMANCE SETS

Moog One allows every Preset to contain up to three separate Synths. These Synths can be split and layered across the keyboard, while maintaining multitimbral MIDI control, and the total number of hardware voices can be allocated between them at will. Each Synth is equipped with its own Arpeggiator and Sequencer. Either (or both) can be easily synced to the Master Clock, or allowed to run freely. In addition, each Synth contains its own distinct sound settings, note range, voice count, MIDI Channel, and more. Collectively, these settings and parameters that define an individual Synth are referred to as a Timbre.

There are two types of audio effects in Moog One: Synth Effects and Master Effects. Each Synth has a dedicated Synth Effect that can be applied to the currently selected Synth voice only. Unlike Synth Effects, Master Effects can be accessed by all three Synth voices simultaneously through dedicated Send level controls located in the Master Effects module.

**NOTE:** *Master Effects work similarly to the Send/Return architecture found on a traditional mixing console.*

Time-stamped, Auto-Saved “Snapshots” keep track of your in-progress edits, and prevent accidental loss of any modified data. Moog One can store thousands of Presets. As a way of providing quick access to specific Presets in a live performance or session environment, Moog One allows the building and saving of up to 128 Performance Sets, which are shortcuts that select specific collections of Presets within the vast Moog One memory. Functionally similar to traditional Bank and Preset selection, each Performance Set offers instant access to up to 64 Presets through the 8x8 matrix of assignable Bank (**A - H**) and Preset (**1 - 8**) buttons found in the Performance Set module.

## VOICE ARCHITECTURE

Moog One provides three incredibly agile and advanced Voltage Controlled Oscillators (VCO). These uniquely Moog Oscillators offer creative access to increased wave-generating dexterity and rich harmonic content. Each Oscillator simultaneously generates a variable-width Pulse wave, plus a Saw or Triangle (switchable) wave, also with variable shape control. Selecting Triangle allows continuous change of the wave's rise and fall times via the **WAVE ANGLE** knob -- sweeping from a Sawtooth to a symmetrical Triangle to a Ramp (Reverse Sawtooth) wave. Selecting Saw varies the reset time of the wave. Individually each wave offers a diverse palette of tonalities. The **MIX** knob sets the blend between the Triangle/Sawtooth wave and the variable-width Pulse wave, creating a world of new and complex wave shapes not traditionally found on an analog synthesizer. Each Oscillator is highlighted by an OLED screen that displays a static image of the resultant wave.

## **VOICE ARCHITECTURE** *(Continued)*

Hard Sync is available on Oscillator 2 and Oscillator 3, with Oscillator 1 being the default source of sync. Oscillator-derived ring modulation, a multi-mode noise generator, and external audio signals are also available as sound sources. In the Mixer module, each sound source can be routed to either a pair of State Variable Filters (SVF), the Ladder Filter, or both. The SVF and Ladder filters can operate in series or parallel with one another, while a dedicated **MIX** knob specifies the output balance between Filters.

In addition, each Synth also has access to four Low Frequency Oscillators (LFO) and three Envelope Generators (EG) per-voice, each equipped with a wealth of extended functions that greatly expand the synthesis capabilities of Moog One. Commonly used modulation routings are hardwired through dedicated front-panel controls. Further assignments can easily be made via the **DEST** buttons located within each LFO and Envelope module.

From the central LCD panel, modulation routings can be tweaked and reassigned using the vast potential of the Modulation Matrix. Assignments can stand alone, or can be mapped through a controller (such as the **MOD WHEEL**, **X/Y PAD**, and **AFTERTOUCH**). Assignable modulation modifiers called Transforms can also be utilized to morph the source signal, providing even greater creative control over modulation.

## **PILOTING MOOG ONE**

As with the Minimoog and Memorymoog before it, Moog One features an angled control panel for improved visibility and ease of operation. This Front Panel provides immediate access to the Moog One sound engine and all of its synthesis parameters. Below the Front Panel you will find an ultra-playable 61-note velocity-sensitive keyboard with aftertouch, and an expressive Left Hand Controller that further extends the dynamic playability of this powerful analog instrument. Around back, the Moog One Rear Panel is home to a vast array of audio, analog control voltage, and expression input and output jacks, as well as MIDI, USB, and Ethernet ports.

## **FRONT PANEL**

The Front Panel is divided into three sections – the Left Panel, the Center Console, and the Right Panel. The Front Panel is always active, in that turning a knob or pressing a button will have an immediate effect. Because Moog One is a fully programmable instrument, however, the position of the Front Panel knobs and buttons will rarely match their currently loaded values. The exceptions are the **MASTER VOLUME** and **HEADPHONES** knobs, which are unaffected by the loading of Presets and Timbres.

***NOTE:** The response behavior of the Front Panel knobs can be specified using the **HARDWARE** settings in the **GLOBAL** menu.*

## **LEFT AND RIGHT PANEL CONTROLS**

The Left and Right Panels are populated with dedicated single-function hardware knobs and buttons that offer immediate control of the Moog One sound engine. These controls are grouped together by module, and modules are grouped together by type. Contained in the Left Panel are the Oscillators, Low Frequency Oscillators (LFO), Noise Generator, Ring Modulator, Arpeggiator, Sequencer, Master Clock, Chord, and Polyphony modules. A distinctive feature of each Oscillator module is the dedicated OLED window, which provides a graphic representation of the composite waveform being output to the Mixer. Contained in the Right Panel are the Mixer, State Variable Filters, Ladder Filter, Envelope Generators (EG), VCA, and Output modules. Also found in the Right Panel are the Synth Effect parameters and the Master Effect sends, which provide access to numerous studio-grade effects, including acclaimed reverbs from Eventide®.

With the exception of the **MASTER VOLUME**, **HEADPHONES**, and **MASTER CLOCK** controls, all of the parameters available on the Left and Right Panels will control the currently selected Synth(s) only.

## KNOBS AND BUTTONS

In this manual, when referring to a specific knob, button, or jack, the name of the control will be presented in **ALL BOLD CAPS** as it appears on the Moog One front or rear panels - for example: **CUTOFF** knob, **SHIFT** button, **MIDI OUT** jack, etc.

Also, in this manual, when referring to the parameter affected by the controller, no bold is used, and only the first letter is Capitalized - for example: the Cutoff frequency, the Shift state, the Preset Library, etc.

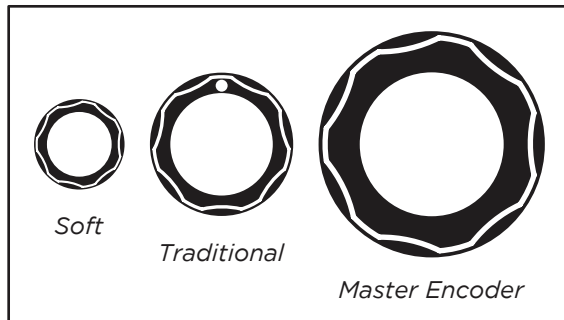

### KNOBS

There are three different types of knobs found on Moog One. Traditional knobs have a fixed functional destination and rotational limitations. Soft Knobs, which change assignment based on the currently selected item on the LCD screen, can be rotated infinitely and are only found below the Center Console Display. Finally, there is a large Master Encoder located in the Center Console that allows for scrolling and selection (by pressing the knob).

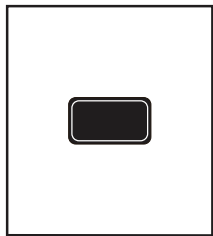

### BUTTONS

Pressing a translucent button will toggle its function On (the LED being lit) and Off, while pressing a solid red button selects a function, state, or option as indicated by a lit LED on the panel.

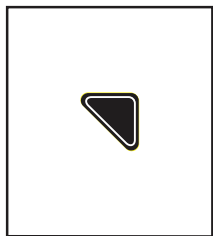

### MORE

Nearly every module is equipped with a triangular **MORE** button located in its upper right corner. When a **MORE** button is pressed, the Center Console Display screen reveals additional parameters specific to that module. These additional parameters are accessed and controlled using the Center Console knobs and buttons.

**NOTE:** Pressing an illuminated **MORE** button will close that parameter window and recall the HOME screen.



### DEST

The four LFOs and three EGs each feature a dedicated **DEST** (Destination) button that provides a simple shortcut for assigning that LFO or EG as a modulation source to a particular destination. Once the **DEST** button is pressed, a modulation routing screen will open in the Center Console Display -- the next Front Panel parameter that is touched or tweaked will become the new modulation destination. As soon as the assignment is made, the modulation amount and additional parameters will appear on the screen.

## CENTER CONSOLE

The upper portion of the Center Console is built around an interactive graphic interface that provides access to a secondary layer of sound design parameters, as well as other Moog One Global parameters. The Center Console Display is operated via four Soft Buttons and four Soft Knobs, all of whose functions change based on the current screen.

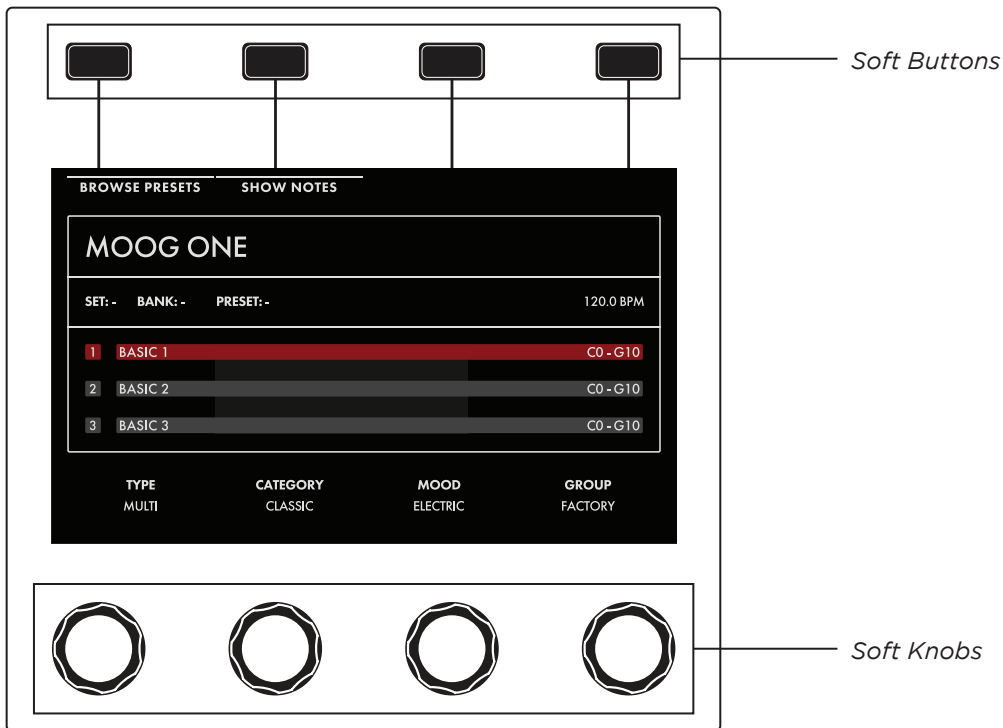

Additionally, there is a large Master Encoder that can be used to scroll through lists and make selections by pushing down on the knob momentarily. In general, parameters are displayed above their respective Soft Knobs in groups of four. Here, values can be edited using the four Soft Knobs. If more than four parameters are available, rotating the Master Encoder will call up the additional rows. Together, the Soft Buttons, Soft Knobs, and Master Encoder provide effortless navigation of the graphic interface.

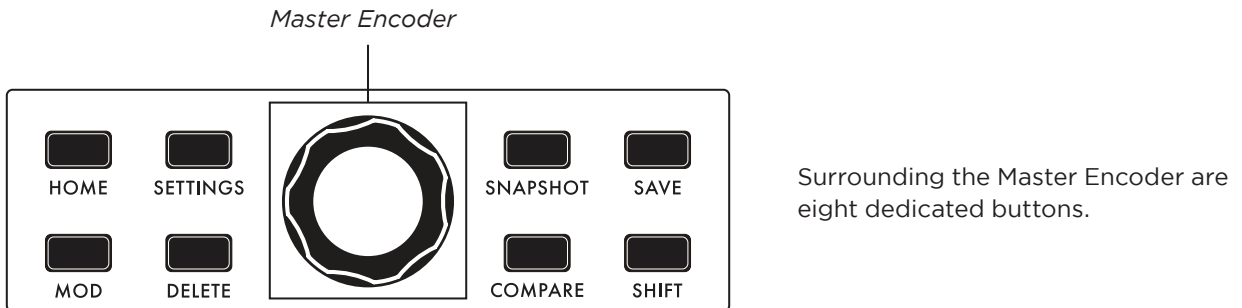

### HOME

Pressing the **HOME** button calls up the HOME screen, which displays the name of the active Preset, the names of the Timbres within the Preset, the respective keyboard ranges and On/Off status of Synth 1, 2, and 3, and the current Master Clock tempo.

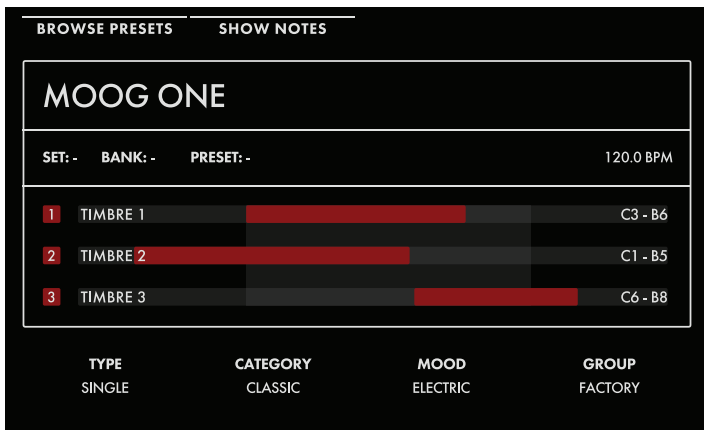

As notes are played on the keyboard, key range indicators will flash to show which Synth(s) are being played from those keys. In addition, the HOME screen shows any tags that have been assigned (Type, Category, Mood, Group) to make the Preset more discoverable in a search.

**NOTE:** Pressing the **HOME** button will exit any currently selected screen and return to the HOME screen.



### SETTINGS

This button provides access to all Moog One Global, Library, and Tuning parameters.

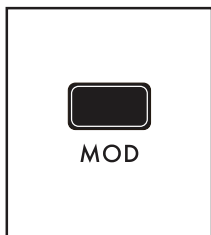

### MOD

The **MOD** button opens the Modulation Matrix screen, where any possible modulation source can be freely routed to any possible modulation destination, and in any amount. A controller, such as the **MOD** wheel, may also be assigned in order to add articulation and expression to a modulation assignment. Additionally, Transforms can be inserted to place high and low limits on the modulation source signal, or to square or cube the modulation source control signal to further expand the variation and expressivity of the Moog One's powerful modulation engine.

**NOTE:** When editing or creating a Modulation Matrix, pressing down on the Master Encoder will toggle back and forth between two sets of parameters (upper and lower) available for each modulation routing.

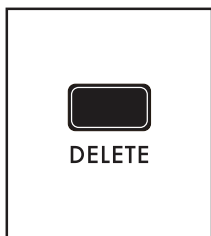

### DELETE

The **DELETE** button is used to remove a modulation routing row, eliminate sequence data, and more. Its specific function is contextual, and is determined by the currently selected screen and parameter.



### SNAPSHOT

Pressing **SNAPSHOT** performs a “micro-save” of the current data as you are editing. Each Snapshot is time stamped, so there is no need to keep saving the data manually under a new Preset name while you are editing. Any Snapshot can be recalled, auditioned, or designated as the “official” version of a Preset when you are saving the data. To view the Snapshots saved with the current Preset, Hold the **SHIFT** and **SNAPSHOT** buttons on the Front Panel.



### SAVE

The **SAVE** button begins the Save process that allows you to store the current settings of the instrument as a Preset. During the Save process, you will also have the ability to add names to the individual Timbres (1, 2, and 3) that are contained within the Preset.

**NOTE:** A full explanation of the save process can be found in the “Saving A Preset” section on page 118.

**NOTE:** The **SAVE** button will light dimly if any parameters have been altered from their originally saved value, reminding you to save your changes if you wish to make them permanent.

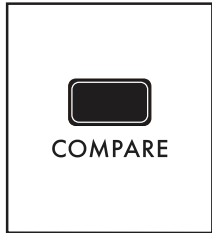

### COMPARE

Pressing the **COMPARE** button places a copied version of the current Preset parameter settings in a separate buffer, so you can tweak one version of a Preset and always compare it to the saved version as you edit.

**NOTE:** Pressing **SHIFT** and **COMPARE** simultaneously (**SHIFT + COMPARE**) creates a new initialized Preset using the Moog One default sound parameters and settings.

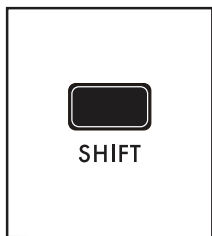

### SHIFT

The **SHIFT** button is most often used in conjunction with another controller or function. For example, holding the **SHIFT** button while operating a Soft Knob parameter allows the value to be edited at a finer level of resolution. **SHIFT** operations can be performed by holding down the **SHIFT** button as you operate the controls. Alternatively, you can enter **SHIFT** mode by pressing and releasing the **SHIFT** button. The button will blink, and any operation performed will behave as if the **SHIFT** button is being held. Moog One will remain in this state until the **SHIFT** button is pressed again, and the blinking has stopped.

## WORKING WITH SYNTHS

Tweaking knobs and pressing buttons has a direct effect on the sound of Moog One. But what exactly is the Front Panel controlling? Remember, a Preset is comprised of up to three Synths -- and one Synth (or more) is always assigned to the Front Panel.

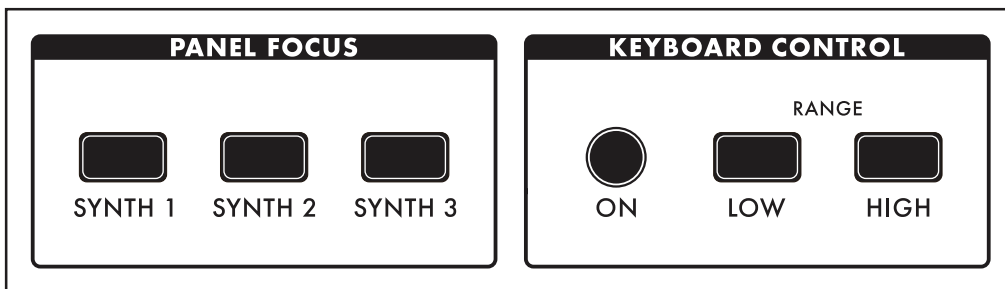

The active Synth is selected using the **SYNTH 1**, **2** and **3** buttons in the Panel Focus module, which allows the Front Panel knobs and buttons to only affect the currently selected Synth(s). Pressing any **SYNTH** button by itself will select just that one Synth. Holding one **SYNTH** button while pressing additional **SYNTH** buttons will select multiple Synths, and allow any tweaks or edits to be applied to all of the selected Synths simultaneously.

**NOTE:** When multiple Synths are selected, the **MORE** pages and the sound engine status LEDs in the LFO, Sequencer, and Arpeggiator modules will reflect the status of the most recently selected Synth. This **SYNTH** button will be illuminated at full brightness, while the initially held **SYNTH** buttons will be lit at a lesser brightness.

## WORKING WITH SYNTHS *(Continued)*

The active Synth can be turned On or Off using the **ON** button located in the Keyboard Control module. In addition, each Synth can be quickly zone-limited to a specific area of the keyboard. To do this, press the **LOW RANGE** button (the LED will light) and then press a key on the keyboard to set the lowest playable note for the selected Synth (the LED goes dark). Next press the **HIGH RANGE** button (the LED will light) and press a key on the keyboard to set the highest playable note for the selected Synth (the LED goes dark). Additional visual confirmation is provided on the HOME page, where the keyboard range for each Synth is shown in red if Keyboard Control is **ON**, and greyed-out if it is Off.

**TIP:** Pressing both the **LOW RANGE** button and the **HIGH RANGE** button at the same time will expand the zone of the active Synth to its full note range of G0 to C10 (MIDI Note 0 - 127).

**TIP:** Press any **SYNTH** button while holding **SHIFT** to solo the selected synth. Repeat to return to standard behavior.

## ADDING EXPRESSION

The Expression Assign buttons provide a convenient way to instantly assign a controller as a modulation source to a specific parameter. Simply press any Controller button in the Expression Assign module, and then tweak a knob or press a button to link the selected controller to that parameter. Once a modulation path has been created, the Quick Assign modulation screen will appear in the Center Console Display. Additional parameters may be accessed here.

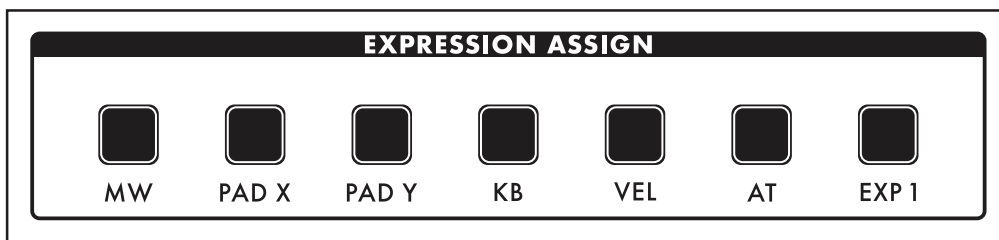

The available controllers are:

- **MW** (Mod Wheel)
- **PAD X** (Pad Position X Axis - horizontal motion)
- **PAD Y** (Pad Position Y Axis - vertical motion)
- **KB** (Keyboard Note Value)
- **VEL** (Keyboard Velocity)
- **AT** (Aftertouch)
- **EXP 1** (Expression Pedal input 1)

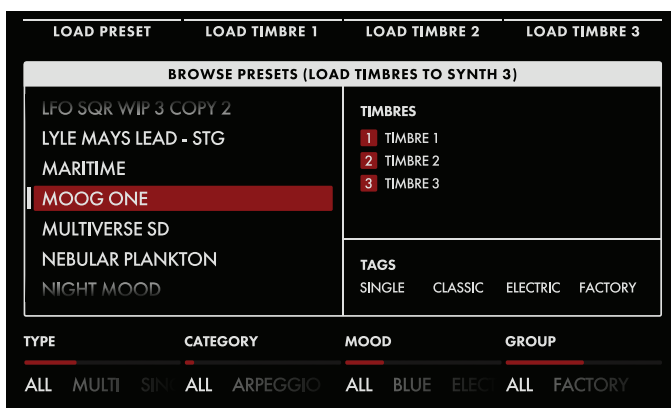

## SELECTING A PRESET

Moog One can store a nearly infinite number of Presets that may be searched and filtered in a variety of ways. From the HOME screen, press the BROWSE PRESETS Soft Button at the upper left of LCD to open the Preset Browser.

## SELECTING A PRESET *(Continued)*

Use the Master Encoder to scroll through the list of available Presets that are displayed on the left pane. Pressing down on the Master Encoder will load the selected Preset; you can also use the LOAD PRESET Soft Button at the top of the screen.

The upper-right pane lists the Timbres used to create this Preset. The lower-right pane lists any tags that have been assigned to this Preset. Tags narrow the list of available selections, making it easier to find a specific or appropriate Preset.

The four Soft Knobs at the bottom of the screen can choose which Presets will be displayed according to TYPE, CATEGORY, MOOD, and GROUP. All tags are user definable, with the exception of TYPE. Only TYPE has fixed options - SINGLE, LAYER, SPLIT, and MULTI. Generally, one would use SINGLE for a Preset using a single Synth. SPLIT for multiple Synths playing in different areas of the keyboard, LAYER for multiple Synths stacked on the same keys, and MULTI for a Preset combining SPLITS and LAYERS, etc.

Presets in Moog One can also be instantly recalled using Performance Sets; the current Performance Set is always accessible from the lower Right Panel. Each Performance Set can recall up to 64 Presets, that are arranged in eight Banks (A - H) of eight Presets (1 - 8). Performance Sets allow you to have select Presets ready and on tap for instant access during a live performance - or even a studio session.

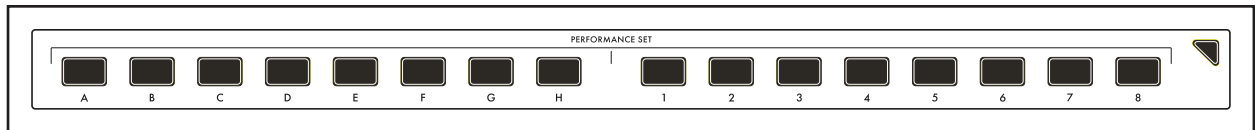

To assign the active Preset to the currently loaded Performance Set, simply press the Bank (A - H) button of your choice, then press and hold the desired Preset (1 - 8) button for 1 second. The Preset button will blink rapidly to let you know your Preset is now assigned to that location.

**NOTE:** *The Performance Set does not itself provide storage of Presets; instead, the Performance Set saves "pointers" that direct Moog One to recall a specific Preset from its memory banks.*

To select a Preset from a Performance Set, simply press a Bank button (A - H), and then press a Preset button (1 - 8) to choose a Preset from your selected Bank.

**NOTE:** *Buttons that are dimly lit indicate that there is a Preset assigned to that button. Buttons that are completely dark indicate that no Preset has been assigned.*



**TIP:** *There is a SHOW BANK PREVIEW option available (under SETTINGS - GLOBAL - HARDWARE SETTINGS). When this function is On, pressing a Bank button will open a screen showing all of the Presets assigned to that Bank.*



## KEYBOARD

Moog One features a premium quality, 61-note keyboard with velocity sensitivity and aftertouch, which are both available as modulation sources. Selectable sensitivity curves are also available to further tailor the keyboard's response to your personal playing style.

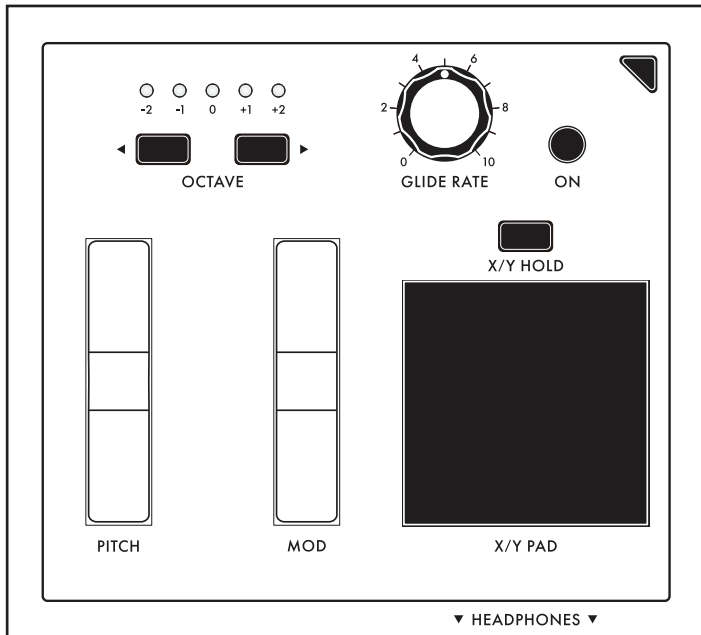

### LEFT HAND CONTROLLER

Located at the left end of the Moog One keyboard, the Left Hand Controller (LHC) provides a number of tools that enhance the playability, performance, and expression of this powerful instrument.

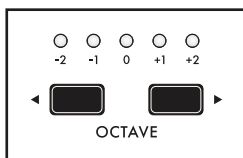

#### OCTAVE

The **OCTAVE** ◀ ▶ buttons allow the keyboard to be shifted up or down by octave. Pressing both **OCTAVE** buttons at the same time will reset the keyboard to its Default Octave.

**NOTE:** Press and hold both **OCTAVE** buttons to send a MIDI Panic (All Notes and Controllers Off) message.

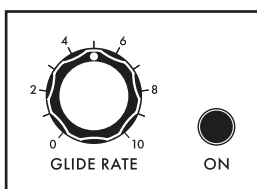

#### GLIDE

Glide delivers a smooth, continuous change in pitch when moving from one note to the next. In addition to the **GLIDE RATE** knob and the **GLIDE ON** button, Moog One offers three types of Glide, as well as additional parameters for Legato, Glissando, and Gated Glide. Pressing the **MORE** button on the Left Hand Controller brings these parameters into view in the Center Console Display.

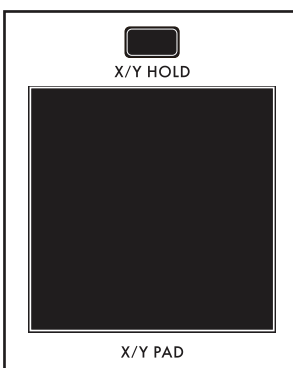

#### X/Y PAD

The **X/Y PAD** is a highly expressive, multidimensional touch surface whose X and Y axes can be easily assigned to a variety of musically useful destinations. There is also a third assignable axis that can sense Pressure on the surface of the pad. The **X/Y PAD** can operate in either a latching or non-latching manner as determined by the state of the **X/Y HOLD** button. If the **X/Y HOLD** button is illuminated, the held value of the **X/Y PAD** can be saved as part of a Preset, similar to the **MOD** wheel amount. Pad pressure also sends a Gate On signal, available as a Control Source in the Mod Matrix.

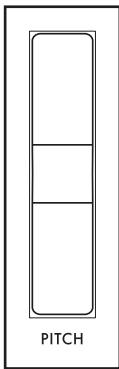

### PITCH

The spring-loaded **PITCH** wheel is used to bend the pitch of the Moog One Oscillators up or down by a predetermined amount. The Pitch Bend Up and Pitch Bend Down range can easily be specified by pressing the **MORE** button on the Left Hand Controller and adjusting each parameter accordingly.

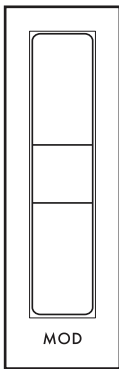

### MOD

The **MOD** wheel is an assignable Controller that is most commonly used to manually determine the amount of modulation being applied from a Source to a Destination. In the case of the Moog One, the **MOD** wheel can also be assigned to multiple locations simultaneously through the Mod Matrix and **EXPRESSION ASSIGN** Buttons.

**NOTE:** The **MOD** wheel position can be saved as part of the Preset.



### HEADPHONES

Located just below the **X/Y PAD** is a pair of front-facing stereo headphone outputs. Use the **HEADPHONES** knob in the Output module to set the volume level for both headphone outputs.

## REAR PANEL

The Moog One Rear panel is equipped with a full complement of audio jacks, communication ports, MIDI connectors, and pedal ports – plus configurable CV In and CV Out connections – to accommodate nearly any use.

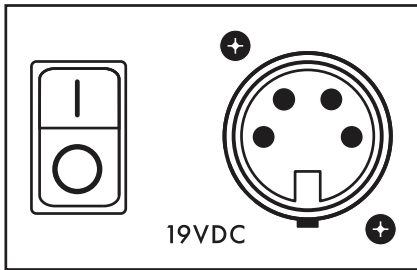

### POWER

Moog One uses an external power supply/adaptor that connects using a locking multi-pin cable. Orient the cable correctly and slide it straight in until it locks. To remove the cable, depress the locking tab on the connector plug and slide the cable straight out. Hold the cable by the locking plug -- never pull on the cable directly. The Moog One On/Off switch is located adjacent to the power port.

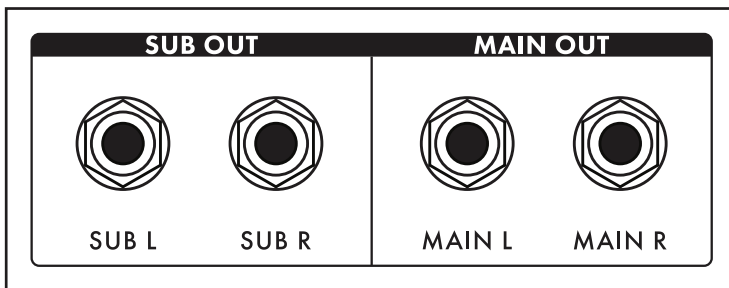

### MAIN OUT/SUB OUT

Moog One features two sets of stereo outputs, the **MAIN L** (Left) and **MAIN R** (Right), and the **SUB L** (Left) and **SUB R** (Right). Both the **MAIN OUTS** and the **SUB OUTS** feature 1/4" balanced TRS jacks. Each Synth can be assigned to either set of outputs – or both.

**NOTE:** The **SUB OUTS** are not affected by the **MASTER VOLUME** knob.

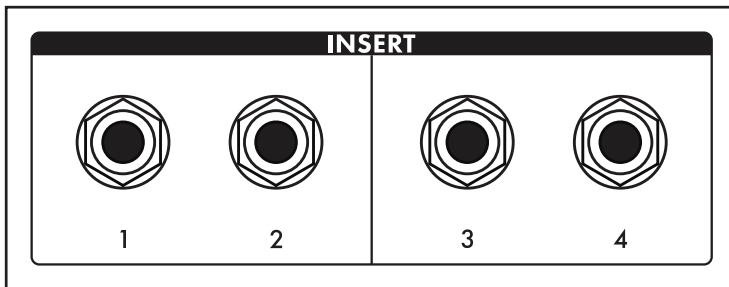

### INSERT 1 2 3 4

Four **INSERT** jacks are provided. Their routing is controlled by pressing the Output Module **MORE** button. The tip of this tip-ring-sleeve jack is wired as the Send, so each **INSERT** jack can be used as an individual output when used with a standard unbalanced TS 1/4" cable. Each Insert jack can also be used with a Y-configuration insert

cable to achieve true insert functionality. The signal is returned to Moog One via the ring connection of the tip-ring-sleeve jack. This allows the active Synth to be sent to, and returned from, an external processor, while still maintaining its place in the internal mix. In addition, the ring/return connectors on adjacent pairs of inserts (**1 & 2**, **3 & 4**) are stereo normalled, so that they can be used as stereo returns. The way this works is that if nothing is connected to the return of Insert **2**, the signal returning via Insert **1** will be summed to both the **MAIN L** and **MAIN R** outputs. Similarly, if nothing is connected to the return of Insert **4**, the signal returning via Insert **3** will be summed to both the **MAIN L** and **MAIN R** outputs.

## REAR PANEL (Continued)

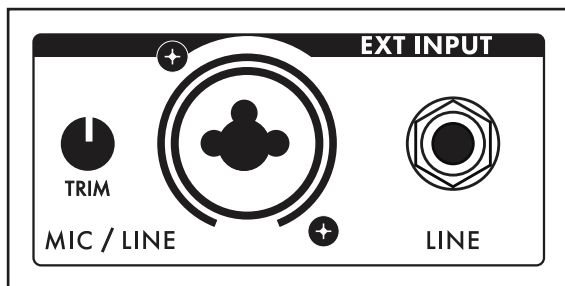

### EXT INPUT

Moog One provides an External Audio Input featuring a Neutrik connector, capable of accepting either a balanced XLR cable, a balanced 1/4" TRS cable, or an unbalanced 1/4" TS cable. The **TRIM** knob can adjust the input gain from -9 dB to +65 dB. There is also a Line Level (**LINE**) input equipped with a 1/4" balanced TRS jack that can accept a balanced 1/4" TRS cable, or an unbalanced 1/4" TS cable. These external inputs

show up in the Moog One Mixer **MORE** screen as an additional sound source with a dedicated channel, although dedicated controls do not exist on the hardware Front Panel. From the Output module's **MORE** page, the **LINE** Input can be routed to the Insert **3** buss, and the XLR/1/4" combo jack can be routed to Insert **4**.

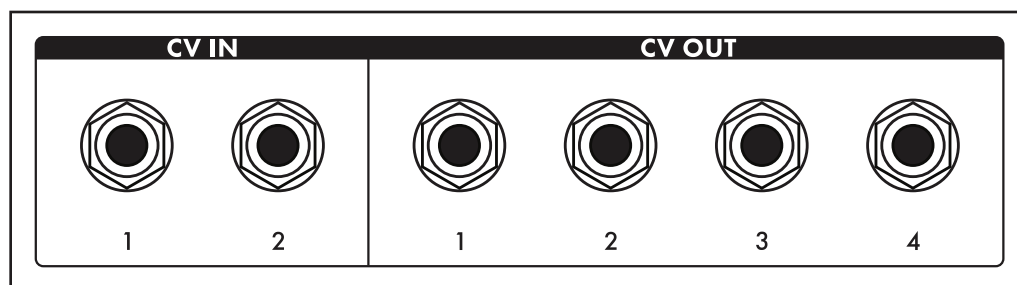

### CV (CONTROL VOLTAGE) I/O

A control voltage is an analog control signal that allows the parameters and functions on one instrument to interact with the parameters and functions of another instrument in the analog domain. In the days before MIDI and USB, control voltage was the primary method for interconnection between synthesizers, and it is still the primary method of interfacing with modular and Eurorack synthesizers today.

Moog One is equipped with two dedicated **CV IN** jacks (**1, 2**) and four **CV OUT** jacks (**1, 2, 3, 4**). Additionally, both expression pedal inputs (**EXP 1, EXP 2**) and the **SUSTAIN** pedal input may also be configured for use as control voltage inputs for further analog control.

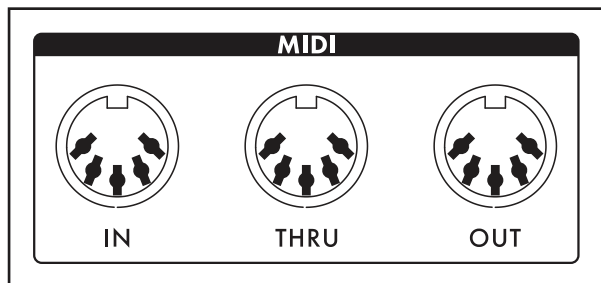

### MIDI (5-PIN DIN)

Moog One offers 5-pin DIN MIDI **IN**, MIDI **THRU**, and MIDI **OUT** jacks to connect directly to other MIDI devices, such as sequencers, drum machines, interfaces, etc. Each Synth in a Preset can operate on a separate MIDI Channel for multitimbral control via external MIDI devices. In addition to note data, the MIDI ports can be configured to respond to MIDI Clock, controllers, expression, SysEx, and more.

## REAR PANEL *(Continued)*

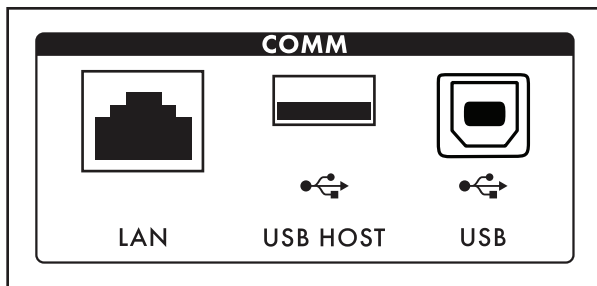

### COMM (COMMUNICATION PORTS)

The **LAN** port enables Moog One to connect directly to a computer network using a CAT-5 cable, which allows for remote servicing and future expansion. The **USB HOST** port provides a convenient way to backup instrument data onto portable USB drives for safe keeping and backline applications. Additionally, the **USB HOST** port can also incorporate any class-compliant MIDI device (one that requires no

additional software drivers) into Moog One operations. The **USB** port found here allows Moog One to communicate directly with your computer via USB, sending and receiving MIDI and other system data.

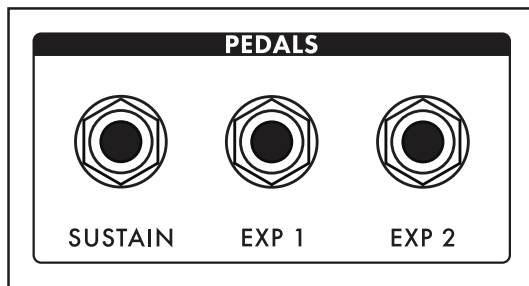

### PEDAL JACKS

Moog One includes three pedal input jacks. One is configured as a sustain (**SUSTAIN**) pedal input, and the other two as expression (**EXP 1**, **EXP 2**) pedal inputs. These inputs can be used to control nearly any Moog One parameter, allowing for a tremendously expressive performance.

**NOTE:** Keep in mind that these pedal jacks can also be used to receive CV signals (via 1/4" TS cables) from other synth modules, Eurorack systems, etc.

## OSCILLATORS

Oscillators are the primary sound source for any synthesizer. Moog One Oscillators have no physical moving parts like a guitar's string or a clarinet's reed. Instead, the Oscillators generate an electronic signal that changes direction very rapidly. The patterns created by these fluctuations determine the waveform, or wave shape, which in turn determines the harmonic content of the signal. Moog One features three independent Oscillators that are nearly identical in design.

Each Oscillator generates two waveforms simultaneously; these can be blended via a dedicated **MIX** control into a single complex, composite wave. For the first waveform, either a Triangle or Sawtooth wave can be chosen. Applying the **WAVE ANGLE** control to the Triangle wave can change the symmetry of the waveform, allowing the Triangle to reach a Ramp or Sawtooth shape at either extreme. Applying the **WAVE ANGLE** control to the Sawtooth wave can vary the reset time, delivering increased harmonic diversity. The second waveform is a Pulse wave with a variable Pulse Width. As with the **PULSE WIDTH** knob, the TRI/SAW **WAVE ANGLE** knob can be modulated from another controller or parameter.

Together, their combined signals can be used to create an endless array of wave shapes that determine each Oscillator's final sonic output. The OLED screen in the center of each Moog One Oscillator provides a static image of this composite waveform.

**NOTE:** The static image displayed on the OLED is created by the Oscillator's parameter settings only, and does not reflect any real-time modulation routings that may also be affecting the final waveform.

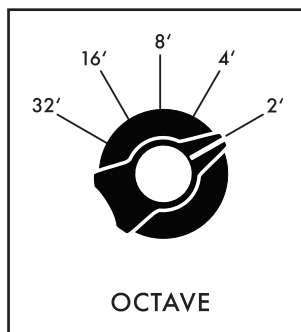

### **OCTAVE** (32', 16', 8', 4', 2')

Rotating the **OCTAVE** knob will change the pitch of the Oscillator by octaves. The historical "foot" settings are a musical convention that relates to pipe lengths on a pipe organ. The 8' setting is considered standard, and will pitch the "C" in the middle of the Moog One keyboard (MIDI Note #60) at "Middle C."

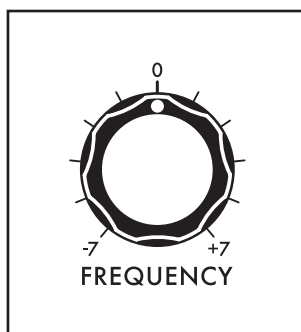

### **FREQUENCY** (-7 to 0 to +7)

While the **OCTAVE** knob sets the Oscillator pitch in octave units, the **FREQUENCY** knob continuously varies the Oscillator pitch over a range of +/- 7 semitones (up or down a perfect fifth).

## OSCILLATORS *(Continued)*



### **BEAT FREQ** (-7 to 0 to +7)

Slightly detuning multiple Oscillators is a classic method for creating huge analog sounds. Moog One adds a Beat Frequency control that can offset the pitch of any Oscillator by a constant amount, which is measured in Hertz (Hz). Use the **BEAT FREQ** knob to create a slight tuning offset per Oscillator. This method provides consistent, musical results over the entire keyboard.

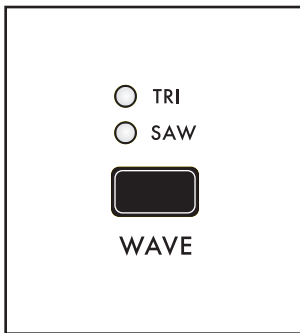

### **WAVE** (TRI, SAW)

The **WAVE** button is used to select either the **TRI** (Triangle wave) or **SAW** (Sawtooth) mode for the first wave generator.

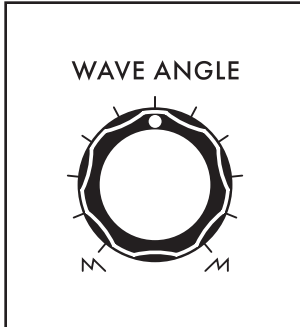

### **WAVE ANGLE**

The function of the **WAVE ANGLE** knob is determined by the **WAVE** button selection.

#### **TRI** (TRIANGLE MODE)

With the **WAVE** button set to **TRI** (the **TRI** LED will be lit), rotating the **WAVE ANGLE** knob will continually vary the wave shape, changing the relationship between the rising and falling segments of the wave.

The center position will create a Triangle wave. Rotating the knob to the far left will produce a wave shape closer to a Sawtooth wave; rotating the knob to the far right will produce a Reverse Sawtooth (or Ramp) wave.

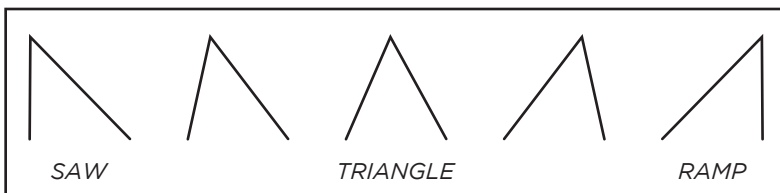

**NOTE:** In **TRI** mode, the rising and falling phases of the wave both scale with pitch -- both get faster at higher pitches, and both get slower at lower pitches.

**TIP:** In **TRI** mode, try modulating the **WAVE ANGLE** to vary the rise and fall segments of the wave, producing a wide variety of timbres traditionally unavailable on an analog synthesizer.

## OSCILLATORS *(Continued)*

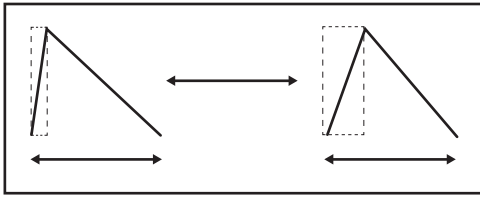

Sawtooth wave is increased, creating a darker and less aggressive timbre. The Wave Angle range is from  $6\mu\text{s}$  to 1 ms.

**NOTE:** In **SAW** mode, modulating the Wave Angle will vary the reset time of the wave, resulting in dynamic variations of timbral complexity.

### **SAW** (SAWTOOTH MODE)

With the **WAVE** button set to **SAW** (the **SAW** LED will be lit), rotating the **WAVE ANGLE** knob will continuously vary the reset time of the Sawtooth wave. Rotating the knob hard left will produce a classic Moog Sawtooth wave with a  $6\mu\text{s}$  (microsecond) reset time. As the **WAVE ANGLE** knob is rotated to the right, the reset time of the

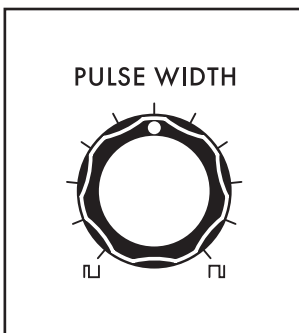

### **PULSE WIDTH**

The second wave generator in each Oscillator creates a pulse wave. Rotating the **PULSE WIDTH** knob will vary the duty-cycle (Pulse Width) of the wave. Rotating the **PULSE WIDTH** knob to the far left will create a narrow pulse with a short duty cycle; the center position will produce a square wave (50% duty cycle); rotating the knob to the far right will produce a wide pulse with a long duty cycle.

**NOTE:** The inverse of a narrow Pulse Wave with a 20% "on" time is a wide Pulse Wave with a 20% "off" time. Graphically, they are mirror images of each other, and their harmonic contents are identical. However, it is the smooth cyclic transition from one to the other that gives Pulse Width Modulation (PWM) its distinctive sound.

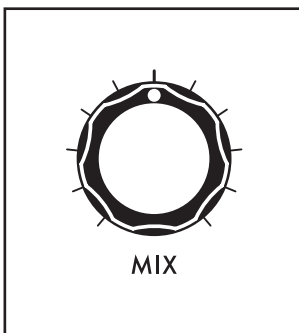

### **MIX**

Using the **MIX** knob, you can create a unique and intricate analog wave shape by combining the outputs of the Triangle/Sawtooth generator and the Pulse/Square generator. The **MIX** knob determines the blend between the two, and the resultant waveform is shown in the individual OLED window for each Oscillator. Rotating the **MIX** knob to the far left outputs the Triangle/Sawtooth only; the center position provides an equal mix of the two generators; rotating the **MIX** knob to the far right will output the Pulse/Square only.



### **HARD SYNC** (OSCILLATOR 2 and OSCILLATOR 3 only)

When an Oscillator is sync'd to the phase of another Oscillator, the sync'd Oscillator is being forced to reset itself to match every waveform peak of the master Oscillator. As the sync'd Oscillator struggles to keep up, the resulting wave shape can become more and more complex.



## OSCILLATORS (Continued)

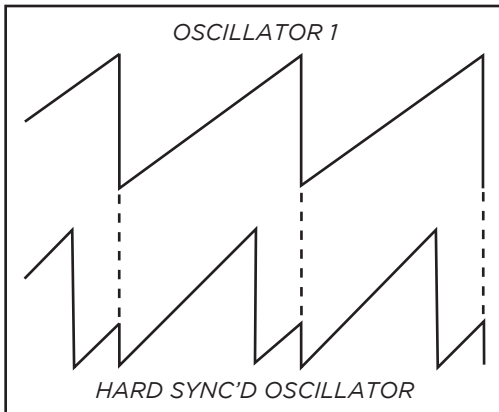

The sound can become aggressive, metallic, or even exhibit elements of comb filtering. Adding modulation to the frequency of a sync'd Oscillator can greatly enhance this effect. Moog One sets Oscillator 1 as the Master Oscillator by default. Use the **HARD SYNC** button to force the selected Oscillator(s) to sync to Oscillator 1.

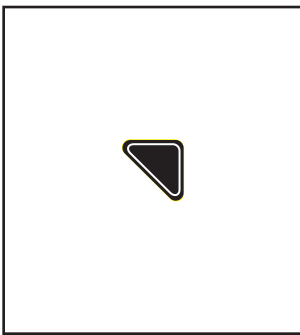

### OSCILLATOR MORE PAGE

Pressing the triangular **MORE** button in the upper right corner of any Oscillator module will reveal a second level of parameters that can be accessed and modified using the Soft Knobs and Master Encoder in the Center Console. These additional parameters are displayed in the bottom portion of the screen. The left pane shows a static representation of the final wave shape output from the Oscillator.

**NOTE:** The static image displayed on the screen is created by the Oscillator's parameter settings only, and does not reflect any real-time modulation routings that may also be affecting the final waveform.

The right pane shows the current value of the Front Panel hardware parameters for this module.

**NOTE:** Pressing the (now) illuminated MORE button will exit the **MORE** page and recall the HOME screen.

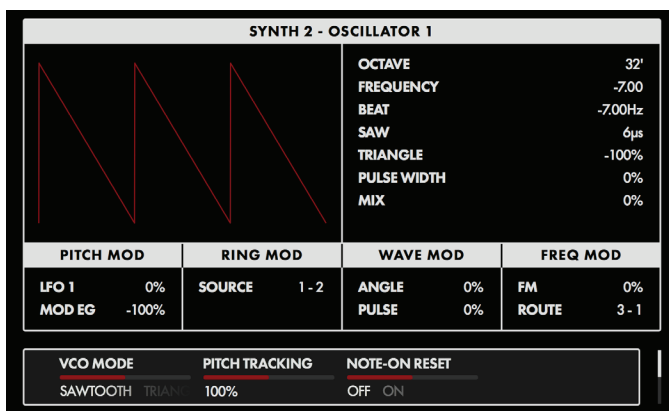

### CHANGING THE VALUE

Rotate the Soft Knob below each parameter name to change its value. In some cases, the Soft Knob simply turns a function on or off. In other cases, the Soft Knob may choose from a range of values or settings.

### SELECTING A ROW

The scroll bar at the right edge of the screen indicates the current row. Rotating the Master Encoder to the right will select the next available row of parameters.

Rotating the Master Encoder to the left will select the previous row. Once selected, rotate the Soft Knob below each parameter name to change its value.

## **OSCILLATORS** *(Continued)*

### **VCO MODE** *(SAWTOOTH, TRIANGLE)*

This parameter shows the status of the **WAVE** button on the front panel. This function can also be controlled here.

### **PITCH TRACKING** *(0 to 200%)*

With this parameter set to 100%, the pitch of the Oscillator will track the keyboard as normal. In some cases you may want to change this value. For example, at 0%, the Oscillator would play the same pitch, regardless of the note played. Another example would be to set an Oscillator to Hard Sync, and utilize an excessive value (150% - 200%) to enhance the effect.

### **NOTE-ON RESET** *(OFF, ON)*

Normally, an Oscillator is constantly running, and each new note played begins from the current point in the waveform cycle. When NOTE-ON RESET is On, the phase of the Oscillator is reset to zero with each new note-on command, which can make for extremely punchy bass sounds.

### **BEND OFFSET**

The Bend Offset amount is set individually for each oscillator, and is combined with the per-Synth Pitch Bend Up and Down values set on the LHC MORE Page. Bend Offset provides separate values for Bend Up and Bend Down, and each can be set to either a positive or a negative value. In this way, the Pitch Bend wheel can be used to resolve each oscillator to a specific note or interval at either end of its travel, allowing for creative harmonies and chords to be introduced as part of a performance.

#### **BEND UP OFFSET** *(-24 to 0 to +24)*

This parameter specifies the amount of Pitch Bend Offset applied to the Oscillator when the Pitch Bend wheel is moved Up. When the value is set to zero no offset is added. Negative offset values will bend the pitch down; positive values will bend the pitch up. The range is +/- 24 semitones (two octaves).

#### **BEND DOWN OFFSET** *(-24 to 0 to +24)*

This parameter specifies the amount of Pitch Bend Offset applied to the Oscillator when the Pitch Bend wheel is moved Down. When the value is set to zero no offset is added. Negative offset values will bend the pitch down; positive values will bend the pitch up. The range is +/- 24 semitones (two octaves).

### **HARD SYNC SRC.** *(Oscillator 2 and Oscillator 3 only)*

The default source for Hard Sync on Oscillator 2 and Oscillator 3 is Oscillator 1. Here, a different oscillator can be designated as the Hard Sync source.

#### **OSCILLATOR 2** *(VCO 1, VCO 3)*

#### **OSCILLATOR 3** *(VCO 1, VCO 2)*

## OSCILLATOR COMMON PARAMETERS

Just below the Oscillator section is a set of controls that affect all three of the oscillators in the active Synth. These parameters are instantly available and are conveniently hard-wired to commonly-used modulation applications.

### PITCH MODULATION

These modulation parameters affect the pitch of all three oscillators.

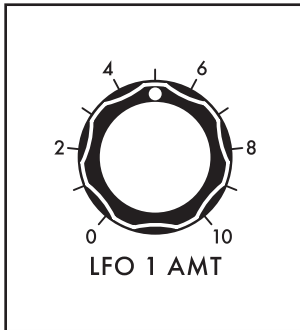

#### LFO 1 AMT (0 to 10)

Turning this knob will determine the amount of LFO 1 being applied as a modulation source to the pitch of all three Oscillators. The higher the value of this knob, the deeper the modulation effect.

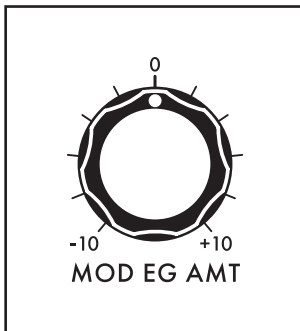

#### MOD EG AMT (-10 to 0 to +10)

Adjusting this knob will determine how much of the control signal from the Modulation Envelope Generator is being applied as a modulation source to the pitch of all three Oscillators. The center position equals zero and produces no effect. Rotating the knob to the right increases the amount of MOD EG signal; rotating the knob to the left inverts the amount of MOD EG signal.

### RING MOD (RING MODULATOR)

Ring Modulation analyzes two input signals to create a new, complex output signal. Mathematically, this output signal is the combined sum and difference of the frequencies of the input signals. Ring Modulation is known for creating metallic, robotic and inharmonic sounds. The output of the **RING MOD** appears in a dedicated channel in the Moog One Mixer module.

**NOTE:** The oscillator signals being fed into the RING MOD are tapped directly from the Triangle/Sawtooth generator, and are not affected by the Oscillators' **PULSE WIDTH** knobs or the Oscillator **MIX** knobs.

**TIP:** Try altering the PITCH TRACKING amount of one of the Oscillators (using the **MORE** button) to emphasize the RING MOD effect. You may want to reduce the volume of the altered Oscillator.

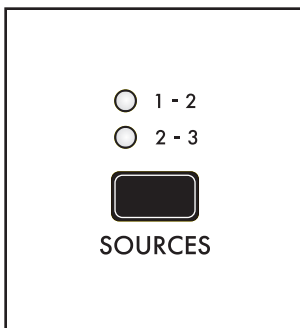

#### SOURCES (1 - 2, 2 - 3)

Use this button to choose which pair of Oscillators will be fed into the RING MOD. The corresponding LED will light.

##### 1 - 2

Oscillator 1 and Oscillator 2 will drive the Ring Modulator.

##### 2 - 3

Oscillator 2 and Oscillator 3 will drive the Ring Modulator.

## WAVEFORM MODULATION

These modulation parameters affect the waveform of the Oscillators. Both knobs are applying LFO 3 to the Oscillator wave shape.

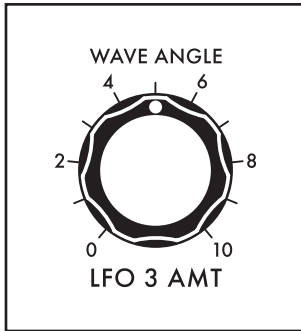

### WAVE ANGLE / LFO 3 AMT (0 to 10)

Turning this knob determines the amount of LFO 3 that is applied as a modulation source to the Oscillators' Wave Angle parameter. The higher the value of this knob, the deeper the effect.

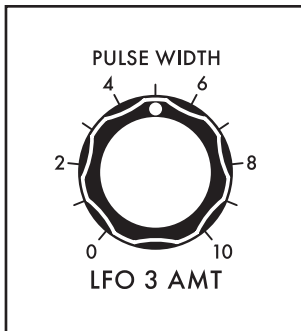

### PULSE WIDTH / LFO 3 AMT (0 to 10)

Turning this knob determines the amount of LFO 3 that is applied as a modulation source to the Oscillators' Pulse Width parameter. The higher the value of this knob, the deeper the effect.

## FM (FREQUENCY MODULATION)

Frequency Modulation (FM) allows the output of one oscillator to modulate the frequency of another oscillator. Applying FM can produce complex sounds and introduce interesting harmonics. Moog One uses linear FM.

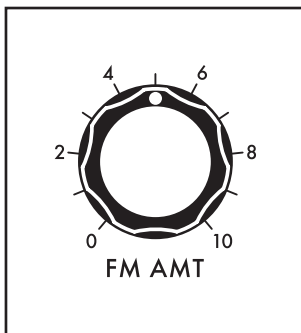

### FM AMT (0 to 10)

Turning this knob determines the amount of Frequency Modulation that is applied from one Oscillator to another. The higher the value of this knob, the deeper the effect.

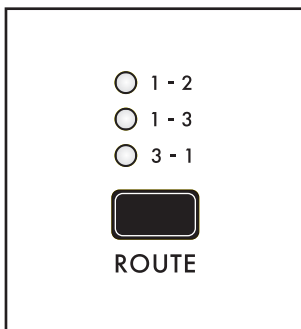

### ROUTE (1 - 2, 1 - 3, 3 - 1)

This button selects the Oscillators and routing scheme for the FM effect. When making a selection, the corresponding LED will light.

#### 1 - 2

The output of Oscillator 1 is modulating the frequency of Oscillator 2.

#### 1 - 3

The output of Oscillator 1 is modulating the frequency of Oscillator 3.

#### 3 - 1

The output of Oscillator 3 is modulating the frequency of Oscillator 1.

## NOISE

In addition to the three Oscillators and the Ring Modulator, Moog One also includes a sophisticated dual source Noise Generator, available as a separate audio source with a dedicated channel in the Mixer module.

Built into the Noise module is a dedicated Envelope Generator to provide independent articulation of the noise. This envelope generator offers a variable **ATTACK** knob, a variable **RELEASE** knob, and a **SUSTAIN** button that allows the Noise generator to continue to sound as long as a note is held.

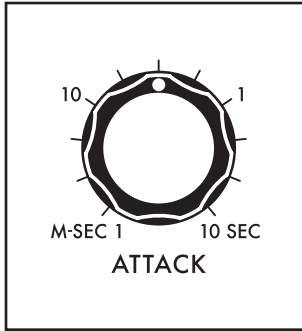

### **ATTACK** (1 M-SEC to 10 SEC)

The **ATTACK** knob sets the Attack Time of the Noise Envelope Generator, controlling how fast the Noise reaches its maximum volume once a key has been pressed or a gate signal received.

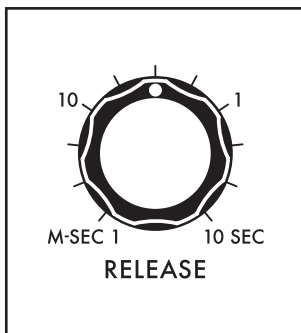

### **RELEASE** (1 M-SEC TO 10 SEC)

The **RELEASE** knob sets the Release Time of the Noise Envelope Generator, controlling how slowly the NOISE fades out after a key is released or the gate is closed.

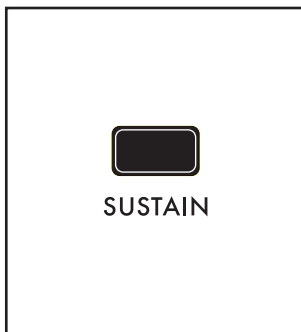

### **SUSTAIN** (ON/LIT, OFF/UNLIT)

When the **SUSTAIN** button is engaged, the Noise Generator will continue to sound as long as a gate is held open, either by pressing the Keyboard, holding a Sustain Pedal, or when receiving a CV Gate. When the **SUSTAIN** button is off, the Release stage will act as more of a Decay stage, fading the sound down as soon as the Attack stage has been completed.

## NOISE *(Continued)*

The Noise generator produces three different colors of noise – White, Red, and Purple. Any two noise colors can be selected at once using the **COLOR** button; the **COLOR MIX** knob creates a blend between those two noise colors.



### COLOR MIX

The **COLOR MIX** knob sets the balance between the two colors of noise selected by the **COLOR** button. Rotating the knob fully to the left will emphasize the color listed in the left column. Rotating the knob fully to the right will emphasize the color listed in the right column. Placing the knob in the center position will provide an even mix between the two.

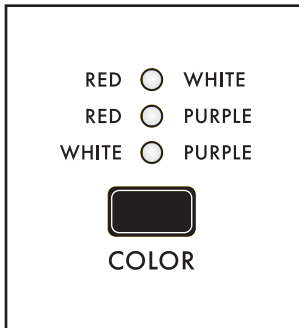

### COLOR

The **COLOR** button specifies which two colors of noise are being blended using the **COLOR MIX** knob - the corresponding LED will light for each selected pair.

#### RED + WHITE

Red Noise and White Noise are selected.

#### RED + PURPLE

Red Noise and Purple Noise are selected.

#### WHITE + PURPLE

White Noise and Purple Noise are selected.

## WHITE NOISE

White Noise is analogous to white light; it contains the same amount of energy across every octave band in the audio spectrum. It's the sound you hear when an old television is set to a non-existing channel.

## RED NOISE

Also referred to as Brownian Noise, Red Noise provides a 6 dB decrease in energy per octave across the audio spectrum as the frequency increases. This greatly curtails the high-frequency Noise components. Red Noise can be thought of as a “rumble” type of Noise.

## PURPLE NOISE

Sometimes called Violet Noise, Purple Noise is the counterpart to Red Noise. Purple Noise provides a 6 dB increase in energy per octave across the audio spectrum as the frequency increases. This greatly reduces the low-frequency Noise components. Purple Noise can be thought of as a “hiss” type of Noise.

**NOTE:** *Pink Noise – a popular element in modular and percussion synthesis – can be approximated by using the **COLOR** button to select **RED + WHITE**, and by then adjusting the **COLOR MIX** knob to taste.*

## MIXER

The Moog One Mixer module provides six input channels and two output busses. The first five inputs – **OSC 1**, **OSC 2**, **OSC 3**, **RING MOD**, and **NOISE** – have dedicated hardware Mixer controls on the Front Panel.

**NOTE:** Pressing the Mixer **MORE** button provides access to the sixth channel – the External Audio Input.

One of the Mixer output busses feeds into the State Variable Filter (SVF), the other into the Moog Ladder Filter. Each input can be bussed to either Filter – or both – using the **SVF** and **LADDER** buss buttons.

Each Mixer Channel features a volume knob. Rotate the knob to the right to raise the level, rotate the knob to the left to lower the level. At the lowest setting (farthest to the left), no signal is entering the mixer.

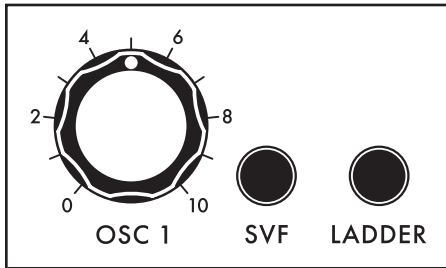

### OSC 1

Use the **OSC 1** knob to set the level of the Oscillator 1 signal as it enters the Mixer. Press the associated **SVF** and **LADDER** buttons to specify which **FILTER(s)** Oscillator 1 is being routed to. When an **SVF** and/or **LADDER** button is lit, it is On, and that filter path is enabled.

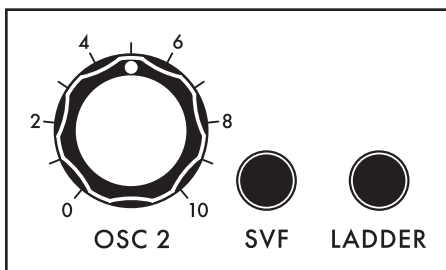

### OSC 2

Use the **OSC 2** knob to set the level of the Oscillator 2 signal as it enters the Mixer. Press the associated **SVF** and **LADDER** buttons to specify which **FILTER(s)** Oscillator 2 is being routed to. When the button is lit, it is On, and that filter path is enabled.

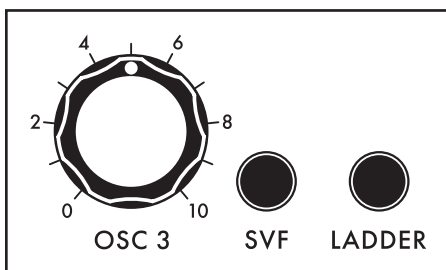

### OSC 3

Use the **OSC 3** knob to set the level of the Oscillator 3 signal as it enters the Mixer. Press the associated **SVF** and **LADDER** buttons to specify which **FILTER(s)** Oscillator 3 is being routed to. When each button is lit, it is On, and that filter path is enabled.

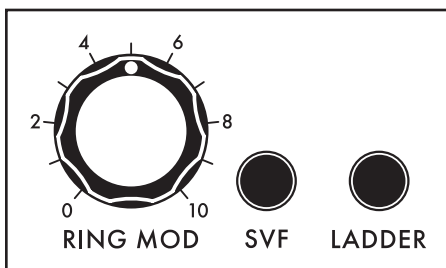

### RING MOD

Use the **RING MOD** knob to set the level of the Ring Modulator signal as it enters the Mixer. Press the associated **SVF** and **LADDER** buttons to specify which **FILTER(s)** the Ring Modulator is being routed to. When each button is lit, it is On, and that filter path is enabled.

## MIXER (Continued)

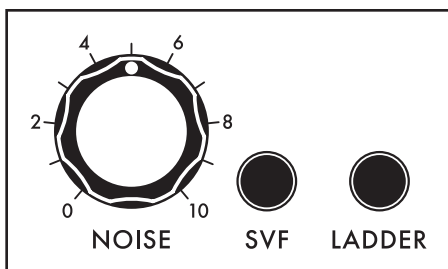

### NOISE

Use the **NOISE** knob to set the level of the Noise Generator signal as it enters the Mixer. Press the associated **SVF** and **LADDER** buttons to specify which **FILTER(s)** the Noise Generator is being routed to. When each button is lit, it is On, and that filter path is enabled.

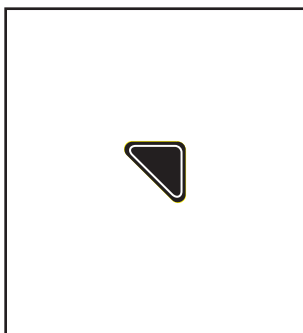

### MIXER MORE PAGE (EXTERNAL INPUT CHANNEL)

Pressing the triangular **MORE** button in the upper right corner of the Mixer module will reveal additional Mixer parameters. The left pane displays the current Mixer input levels, bar-graph style. The square boxes associated with each input turn white to indicate which Filter buss(es) are in use. The first column of boxes indicates the SVF filters, the second column indicates the Ladder filter. This visual information reflects the physical knob and button settings from the Front Panel controls. The right pane shows the current value of the Front Panel hardware parameters for this module.

The final Mixer input channel is labelled External, and has no corresponding Front Panel hardware. Instead, this input is controlled using the first three Soft Knobs at the bottom edge of the screen.

**NOTE:** Pressing the (now) illuminated **MORE** button will exit the **MORE** page and recall the **HOME** screen.

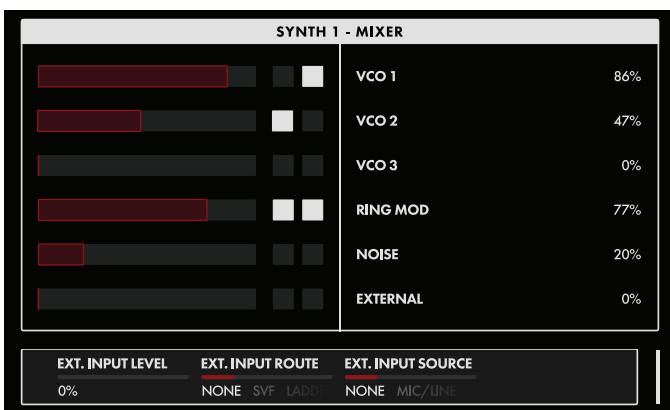

The onscreen **MORE** page parameters are edited using the soft knobs below the screen.

### CHANGING THE VALUE

Rotate the Soft Knob below the parameter name to change its value. In some cases, the Soft Knob simply turns a function on or off. In other cases, it may choose from a list of values or settings, and in yet other cases, the soft knob is dialing in a value – either an absolute value or a percentage.

### EXT. INPUT LEVEL (0% to 100%)

This parameter sets the input level to the mixer from the External Audio Input signal.

### EXT. INPUT ROUTE (NONE, SVF, LADDER, BOTH)

This parameter specifies which Filter(s) the External Audio Input signal is being routed to.

### EXT. INPUT SOURCE (NONE, MIC/LINE, LINE, MIC/LINE+LINE)

This parameter specifies which physical **EXT. INPUT** jack(s) is the source of the **EXT. INPUT** signal.



## FILTERS

Technically, Moog One employs three analog Filters to provide dynamic tone-sculpting. A pair of State Variable Filters (SVF) function as a single unit; their configuration is determined by their parameter settings. The third filter is a classic Moog transistor Ladder Filter. The SVF and Ladder Filter can run side by side in the Parallel mode, or they can feed from SVF into the Ladder using the Series mode. This combination of Filter types and routings provides extensive control of the timbre, harmonic content, and final character of the sound. In turn, this flexibility allows Moog One to recreate a vast array of filter schemes that have appeared in countless classic (as well as obscure) synthesizers and modules, and also combine them to create completely new, unique sounds.

In both the State Variable Filter (SVF) and Ladder Filter, the basic parameters are the same. The **CUTOFF** knob specifies the operating frequency of the Filter. The Cutoff Frequency may represent an upper frequency limit, lower frequency limit, or center frequency value, depending on the Filter **MODE** selected. The **RESONANCE** knob routes a portion of the Filter's output signal back to the input of the Filter, emphasising the Cutoff Frequency. The Cutoff Frequencies of the SVF and Ladder Filter can be linked together and operated simultaneously from either **CUTOFF** knob.

**NOTE:** When designing sounds, remember that each source can be routed to either Filter individually, or to both.

### STATE VARIABLE FILTER (SVF)

The SVF is constructed using two identical filter circuits that together behave as one; their arrangement and interaction is determined by the choice of NOTCH, Bandpass (BP), High Pass (HP), or Low Pass (LP) Modes on the Front Panel, and by other parameters located in the Filter MORE page.

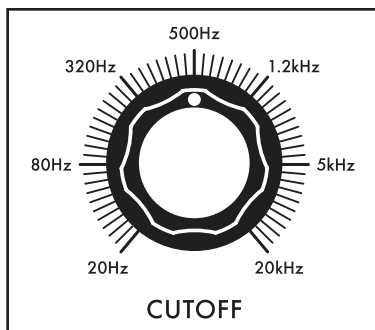

#### **CUTOFF** (20Hz to 20kHz)

Rotate this knob to set the operating frequency of the SVF Filter. The function of the selected frequency will depend on the selected Filter **MODE**.

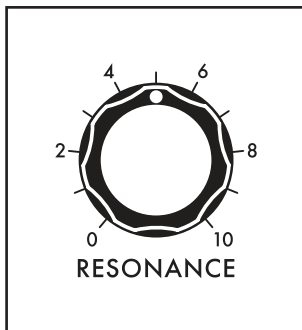

#### **RESONANCE** (0 to 10)

As the value of the **RESONANCE** knob is increased, more emphasis is applied at the Cutoff Frequency of the Filter. This will boost the prominence of any harmonic content in your sound that is at or near the Cutoff Frequency.

## FILTERS *(Continued)*

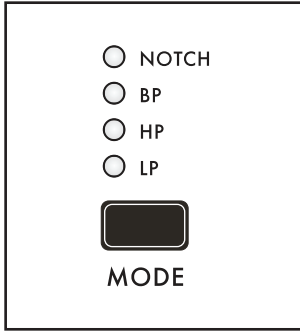

### **MODE** (*NOTCH, BP, HP, LP*)

Pressing this button cycles through the four available SVF Filter Modes. The associated LED will light to indicate your selection.

#### **NOTCH** (*NOTCH*)

In Notch Mode, harmonic content contained in a band centered around the Cutoff Frequency is attenuated, while the frequencies outside this band – both above and below – can freely pass.

#### **BP** (*BAND PASS*)

Band Pass Mode is the opposite of Notch Mode. Harmonic content contained in a band centered around the Cutoff Frequency is allowed to pass, while the frequencies outside this band – both above and below – will be attenuated.

#### **HP** (*HIGH PASS*)

In the High Pass Mode, harmonic content above the Cutoff Frequency is allowed to pass, and the lower frequencies are attenuated.

#### **LP** (*LOW PASS*)

In the Low Pass Mode, harmonic content above the Cutoff Frequency is attenuated, and the lower frequencies are allowed to pass.

### **LADDER FILTER** (*LADDER*)

The Ladder Filter is based on the classic Moog transistor-network Ladder design. As with the SVF, the Ladder Filter offers different Modes of operation. In addition, the Ladder Filter offers four distinct attenuation slopes.

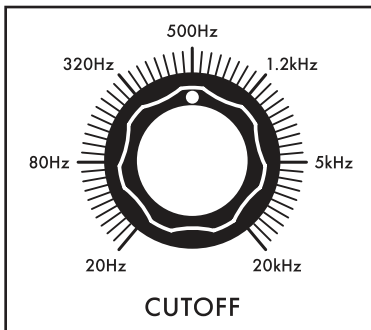

#### **CUTOFF** (*20Hz to 20kHz*)

Rotate the **CUTOFF** knob to set the operating frequency of the Ladder Filter. The function of the selected frequency will depend on the selected Filter **MODE**.

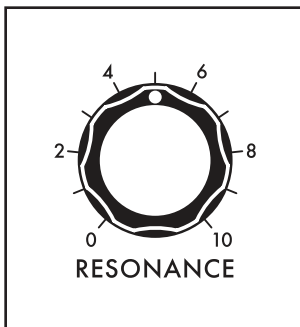

#### **RESONANCE** (*0 to 10*)

As the value of the **RESONANCE** knob is increased, more emphasis is applied at the Cutoff Frequency of the Filter. This will boost the prominence of any harmonic content in your sound that is at or near the Cutoff Frequency. By turning the **RESONANCE** knob all the way up and lowering the **CUTOFF** knob, the Filter can be coaxed into a self-oscillating state, acting as a sine-wave oscillator whose pitch is determined by the Filter's Cutoff Frequency.

## FILTERS *(Continued)*

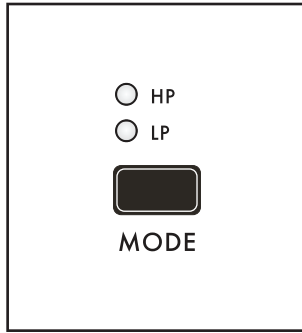

### **MODE** *(HP, LP)*

Pressing the **MODE** button toggles between the two Ladder Filter Modes. The associated LED will light to indicate your selection.

#### **HP** *(HIGH PASS)*

In the High Pass Mode, harmonic content above the Cutoff Frequency is allowed to pass, and the lower frequencies are attenuated.

#### **LP** *(LOW PASS)*

In the Low Pass Mode, harmonic content above the Cutoff Frequency is attenuated, and the lower frequencies are allowed to pass.

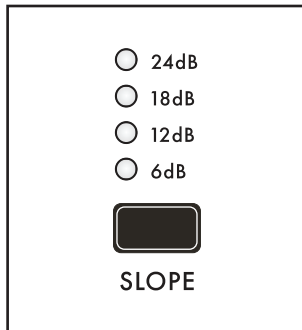

### **SLOPE** *(24 dB, 18 dB, 12 dB, 6 dB)*

Pressing this button cycles through the Filter's available Slope settings. The associated LED will light to indicate your selection.

#### **24 dB**

Using this setting, the Ladder Filter attenuates the frequencies above (LP Mode) or below (HP Mode) the Cutoff Frequency at a rate of 24 dB per octave. The original Moog Ladder filter operated at 24 dB per octave.

#### **18 dB**

Using this setting, the Ladder Filter attenuates the frequencies above (LP Mode) or below (HP Mode) the Cutoff Frequency at a rate of 18 dB per octave.

#### **12 dB**

Using this setting, the Ladder Filter attenuates the frequencies above (LP Mode) or below (HP Mode) the Cutoff Frequency at a rate of 12 dB per octave.

#### **6 dB**

Using this setting, the Ladder Filter attenuates the frequencies above (LP Mode) or below (HP Mode) the Cutoff Frequency at a rate of 6 dB per octave.

## FILTER COMMON PARAMETERS

These parameters apply to both the SVF and Ladder Filter simultaneously; they determine how the Filters operate together.

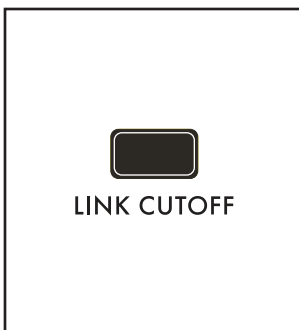

### **LINK CUTOFF** *(ON/LIT, OFF/UNLIT)*

When this parameter is on, operating either the SVF **CUTOFF** knob or the Ladder **CUTOFF** knob will uniformly change both of their Cutoff Frequencies. The relative offset between the Cutoff Frequency settings of the Filters is preserved as the linked value is increased or decreased.

**NOTE:** *In a situation where tweaking one of the **CUTOFF** knobs causes either parameter to reach its high or low limit, it will remain at that limit. The relative offset will be restored when the parameter is no longer at its limit.*

## FILTERS *(Continued)*

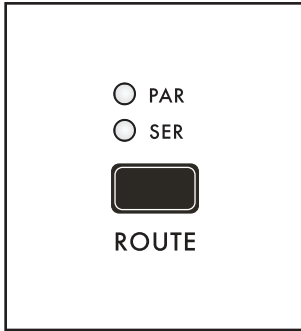

### **ROUTE** *(PAR, SER)*

Pressing the **ROUTE** button cycles through the available Filter Routings. The associated LED will light to indicate your selection.

#### **PAR** *(PARALLEL)*

When Parallel Routing is selected, the SVF and Ladder Filter operate individually, side by side.

#### **SER** *(SERIES)*

When Series Routing is selected, the output of the SVF feeds into the input of the Ladder Filter, forming a continuous “filter chain.”

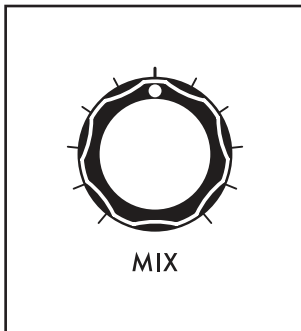

### **MIX**

The balance between the two Filter outputs is controlled using the **MIX** knob. The center position represents an equal blend of the two filter modules. Turning the **MIX** knob to the left will favor the SVF output; turning the **MIX** knob to the right will accentuate the Ladder Filter output.

**NOTE:** To listen to the serial output of both filters, assign any source(s) to the SVF filter only, and then rotate the **MIX** knob all the way to the right (100% Ladder). The SVF output will feed the Ladder filter input, and the Ladder output will be the result of both filters in series.

## CUTOFF MODULATION

The Filter module also contains three Cutoff Modulation parameters – **EG AMT**, **LFO 2 AMT**, and **FM AMT**. These frequently used modulation sources are instantly available and are conveniently hard-wired to each Filter’s Cutoff Frequency. These parameters can be adjusted independently for the SVF and Ladder Filter, or they can be applied to both at once.

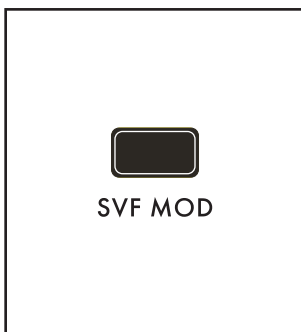

### **SVF MOD** *(ON/LIT, OFF/UNLIT)*

When this button is lit, the **EG AMT**, **LFO 2 AMT**, and **FM AMT** knobs will set the modulation for the Cutoff Frequency of the State Variable Filter. When **SVF MOD** is unlit, the knobs no longer adjust the SVF modulation amount, but any previous modulations set for the SVF will remain.

### **LADDER MOD** *(ON/LIT, OFF/UNLIT)*

When this button is lit, the **EG AMT**, **LFO 2 AMT**, and **FM AMT** knobs will set the modulation for the Cutoff Frequency of the Ladder Filter. When **LADDER MOD** is unlit, the knobs no longer adjust the Ladder Filter modulation amount, but any previous modulations set for the Ladder Filter will remain.

**NOTE:** The **SVF MOD** and **LADDER MOD** buttons can be On (lit) simultaneously by pressing both buttons at the same time. In this case, the **EG AMT**, **LFO 2 AMT**, and **FM AMT** knobs will affect the modulation amounts for both Filters.

## FILTERS *(Continued)*

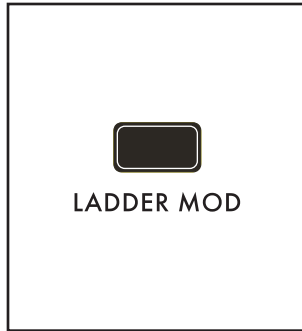

### **LADDER MOD** *(ON/LIT, OFF/UNLIT)*

When this button is lit, the **EG AMT**, **LFO 2 AMT**, and **FM AMT** knobs will set the modulation for the Cutoff Frequency of the Ladder Filter. When **LADDER MOD** is unlit, the knobs no longer adjust the Ladder Filter modulation amount, but any previous modulations set for the Ladder Filter will remain.

**NOTE:** The **SVF MOD** and **LADDER MOD** buttons can be On (lit) simultaneously by pressing both buttons at the same time. In this case, the **EG AMT**, **LFO 2 AMT**, and **FM AMT** knobs will affect the modulation amounts for both Filters.

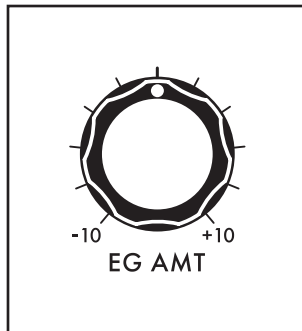

### **EG AMT** *(-10 to 0 to +10)*

This knob sets the amount of control signal generated by the Filter Envelope that will be applied as a modulation source to the Cutoff Frequency of the selected Filter(s). In the center position, the **EG AMT** knob will have no effect. Turning the knob to the right will increase the amount of positive modulation being applied. Turning the knob to the left will increase the amount of negative (or inverse) value being applied.

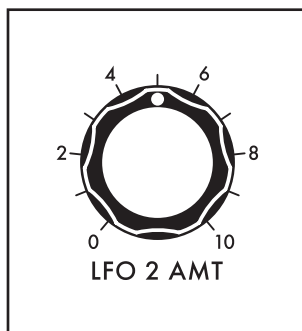

### **LFO 2 AMT** *(0 to 10)*

The amount of modulation signal generated by LFO 2 that will be applied to the Cutoff Frequency of the selected Filter(s) is determined by this knob. At the far left setting, no modulation is applied. Turn the knob to the right to apply more modulation signal.

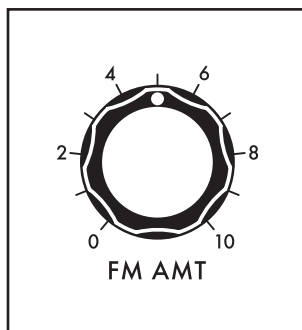

### **FM AMT** *(0 to 10)*

The amount of modulation signal generated by the FM (Frequency Modulation) Source that will be applied to the Cutoff Frequency of the selected Filter(s) is determined by this knob. At the far left setting, no modulation is applied. Turn the knob to the right to apply more modulation signal.

**NOTE:** The modulation source for the **FM AMT** knob is selected in the Filter MORE page. An independent FM Source can be set for the Ladder filter and for the SVF.

## FILTER MORE PAGE

Pressing the triangular **MORE** button in the upper right corner of the Filter Module will reveal a second level of parameters that can be accessed and modified using the interactive portion of the Center Console. These additional parameters are displayed in the bottom portion of the screen. The left pane offers a visual representation of the two filter modules. The right pane shows the current value of the Front Panel hardware parameters for this module. Tweaking these panel controls will update their values here.

**NOTE:** Pressing the (now) illuminated **MORE** button will exit the **MORE** page and recall the **HOME** screen.

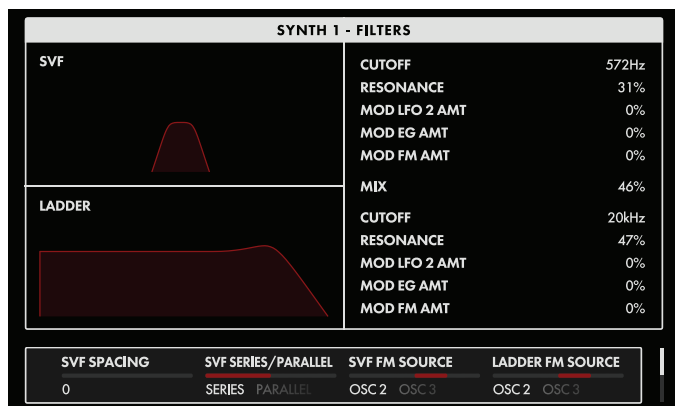

The onscreen **MORE** page parameters are edited using the four Soft Knobs below the screen.

## CHANGING THE VALUE

Rotate the Soft Knob below the parameter name to change its value. In some cases, the Soft Knob simply turns a function on or off. In other cases, the Soft Knob may choose from a list of values or settings, and in other cases, the Soft Knob is dialing in a value – either absolute or a percentage.

## SELECTING A ROW

The scroll bar at the right edge indicates the current row. Rotate the Master Encoder to the right to highlight the next row of parameters. Rotating the Master Encoder to the left will select a previous row. Again, rotate the Soft Knob below a parameter to change its value.

### SVF SPACING (-100% to 0 to +100%)

This parameter sets up an offset in the Cutoff Frequency value between the two filter elements that comprise the State Variable Filter. The SVF Cutoff Frequency sets the value of filter element A; the SVF SPACING parameter sets the Cutoff Frequency of element B above or below that value. When the value of this parameter is set to 0, the Cutoff Frequency of the two elements is the same. Positive values raise the Cutoff Frequency of element B in relation to element A; negative values will lower it.

### SVF SERIES/PARALLEL (SERIES, PARALLEL)

This parameter determines how the two filter elements that comprise the SVF module will arrange themselves. When Series is selected, the output of element A will feed the input of element B. By selecting Parallel, the two filters will operate side by side.

**NOTE:** Although sharing similar attributes, this parameter has a different function than the **SER / PAR ROUTE** button on the Front Panel. That button specifies whether the SVF and Ladder Filter are running in Series or Parallel. The SVF **SERIES / PARALLEL** selection only affects the elements inside the SVF module.

### SVF FM SOURCE (OSC 1, OSC 2, OSC3)

This parameter determines which Oscillator will serve as the Frequency Modulation source for the SVF. When applying FM, the **SVF MOD** button needs to be On (lit), and the **FM AMT** knob sets the amount.

### LADDER FM SOURCE (OSC 1, OSC 2, OSC3)

This parameter determines which Oscillator will serve as the Frequency Modulation source for the Ladder filter. When applying FM, the **LADDER MOD** button needs to be On (lit), and the **FM AMT** knob sets the amount.

## **FILTER MORE PAGE** *(Continued)*

### **SVF KEY TRACK** *(-200% to +200%)*

Keyboard Tracking allows the Cutoff Frequency of the Filter to track the keyboard in the same way an Oscillator would. In this way, higher notes on the keyboard will be filtered differently than lower notes. At 100%, the Filter is tracking the keyboard at the same rate as the default Oscillator tracking. At 0%, the SVF KEY TRACK parameter is effectively Off, and not tracking the keyboard at all. Below zero, tracking has a negative (inverse) value.

### **LADDER KEY TRACK** *(-200% to 200%)*

Keyboard Tracking allows the Cutoff Frequency of the Filter to track the keyboard in the same way an Oscillator would. In this way, higher notes on the keyboard will be filtered differently than lower notes. At 100%, the Filter is tracking the keyboard at the same rate as the default Oscillator tracking. At 0%, the LADDER KEY TRACK parameter is effectively Off, and not tracking the keyboard at all. Below zero, tracking has a negative (inverse) value.

**TIP:** *Applying KEY TRACK at 100% to a self-oscillating Filter will allow it to be played from the keyboard as an additional “oscillator.”*

## ENVELOPES

Sounds change over time, and how they change over time is part of what makes a sound unique. Each sound has a beginning, an end, and some things that happen in between. Some sounds begin abruptly, like the strike of a drum. Some sounds end just as quickly, and some linger like a held chord on a piano. This start-to-finish profile is known as the envelope of a sound.

In synthesis, the Envelope Generator (EG) is one of the most useful and versatile modulation sources. Traditionally, four individually controlled parameters – Attack Time, Decay Time, Sustain Level, and Release Time – allow the Envelope Generator to create a complex (ADSR) control signal that can be used to evolve a sound over time. Moog One adds additional Delay Time and Hold Time parameters (DAHDSR) to each Envelope, as well as selectable Curves for each stage, Looping and Latching EG modes, Time Scaling, Multi Triggering, and even Sync, to generate a much more useful EG signal.

Three independent Envelope Generators are provided – the Filter Envelope, the Amplifier Envelope, and the Modulation Envelope. By default, the Filter Envelope modifies the timbre of a sound over time, the Amplifier Envelope modifies the amplitude (loudness) over time, and the Modulation Envelope is available as a modulation source for any parameter, though it is also hardwired to the **MOD EG AMT** control in the Pitch Modulation section of the Oscillator module. In practice, any EG can be used as a modulation source for any modulation destination. The parameters defined below are identical for each Moog One Envelope.

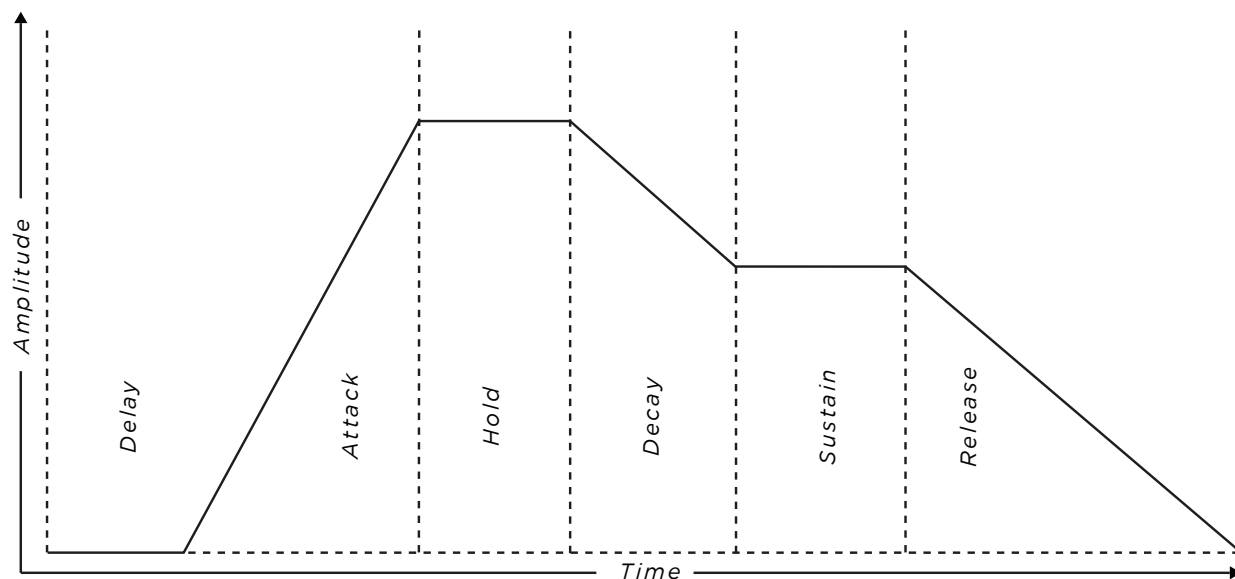

In this diagram, you can see how the Delay Time, Attack Time, Hold Time, Decay Time, Sustain Level, and Release Time work together to form a continuous control signal. The Envelope begins as the key is pressed, and the Release stage begins when the key is released. An external gate can also be used to trigger an Envelope.

**NOTE:** Although the value for the Attack Time, Decay Time, and Release Time are given as M-SEC 1 (one millisecond) to 10 SEC (ten seconds), it is possible to set these parameters to an even smaller near-zero value, indicated as MIN (minimum) by rotating the knob all the way to the left. This MIN setting makes the value less sensitive to the effects of the TIME SCALE parameter (Envelope MORE page).



## ENVELOPES *(Continued)*

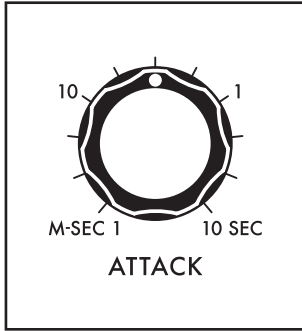

### **ATTACK** (1 M-SEC to 10 SEC)

The **ATTACK** knob determines the amount of time required for the control signal to rise from zero to its maximum level once a key is pressed or a gate is initiated. Rotating the knob to the right will increase the Attack Time.

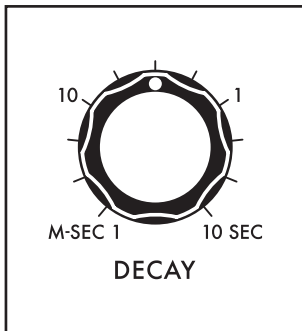

### **DECAY** (1 M-SEC to 10 SEC)

The **DECAY** knob determines the amount of time required for the control signal to fall from the maximum level achieved by the Attack stage before reaching the Sustain Level when a key is held or a gate is open. Rotating the knob to the right will increase the Decay Time.

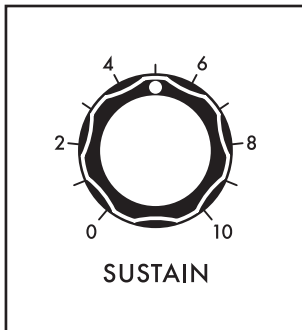

### **SUSTAIN** (0 to 10)

The **ATTACK**, **DECAY**, and **RELEASE** knobs control the amount of time needed to complete their respective stages. The **SUSTAIN** knob instead controls the level that the Envelope control signal will maintain while a key remains pressed (or a gate remains open). Higher values will produce a higher Sustain Level.

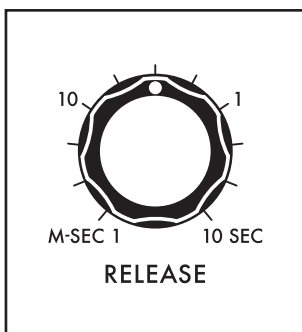

### **RELEASE** (1 M-SEC to 10 SEC)

After the key is released (or the gate is closed), the Envelope enters the Release stage. The **RELEASE** knob determines the amount of time required for the control signal to fall from its current level back to zero. Rotating the knob to the right will increase the Release Time.

**NOTE:** If the key is released (or the gate is closed) before the Attack and/or Decay stages are complete, the Envelope will simply advance to the Release stage.

## ENVELOPES *(Continued)*



### **MULTI TRIG** *(ON/LIT, OFF/UNLIT)*

This setting provides improved articulation while playing in the **MONO** or **UNISON** Modes. With the **MULTI TRIG** (Multiple Triggering) button set to Off, a new note played while one is still being held on the keyboard (legato style) will not initiate a new Envelope cycle; instead the new note will sound at the current position of the active Envelope. Multiple Triggering (**MULTI TRIG** button On) begins a new Envelope cycle with each new note played. When playing polyphonically, if a particular voice is re-triggered by a new note while still playing the previous note, the Envelope will restart (**MULTI TRIG** On) or not (**MULTI TRIG** Off).

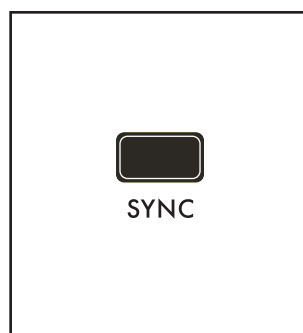

### **SYNC** *(ON/LIT, OFF/UNLIT)*

When the **SYNC** button is On, the seconds-based timing of the Envelope's Delay, Attack, Hold, Decay, and Release stages is replaced by quantized musical divisions of the Master Clock's Tempo (BPM). This allows the Envelopes to operate in sync with other modules using clock-division timing, including the Arpeggiator, Sequencer, LFOs, Effects, etc. The complete **SYNC** value range for the envelopes is: {1/64, 1/32, 1/16, 1/8, 1/4, 1/2, 1, 2, 4, 8, 16, 32, 64}

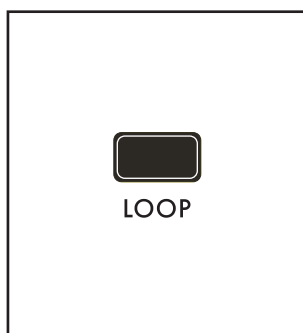

### **LOOP** *(ON/LIT, OFF/UNLIT)*

With the **LOOP** button On, the Envelope forms a repeating control signal based on the values of the Delay, Attack, Hold, Decay, Sustain, and Release stages. As soon as the Release stage is complete, the Delay stage will begin anew. This type of repeating control signal is also known as a trapezoid signal.

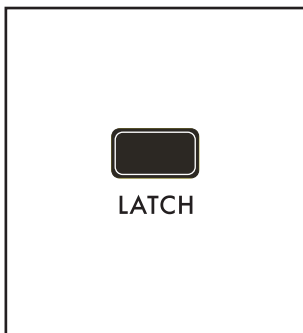

### **LATCH** *(ON/LIT, OFF/UNLIT)*

Setting the **LATCH** button to On holds the Envelope open at the Sustain level, even after a key is released or the gate is closed. With the **LATCH** button On and the **LOOP** button set to On, the Envelope continues to cycle and loop, even after the key (or gate) is released.

## ENVELOPES (Continued)

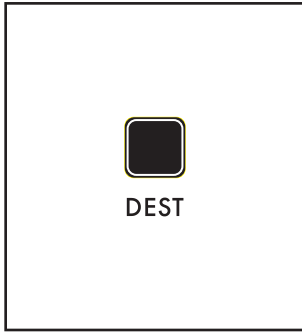

### DEST

The **DEST** (Destination) button provides an intuitive and simple shortcut for establishing a modulation route using this Envelope as the source. Once the **DEST** button is pressed, the Modulation Quick Assign screen will open in the Center Console Display. The next Front Panel parameter that is touched or tweaked will become the modulation destination.

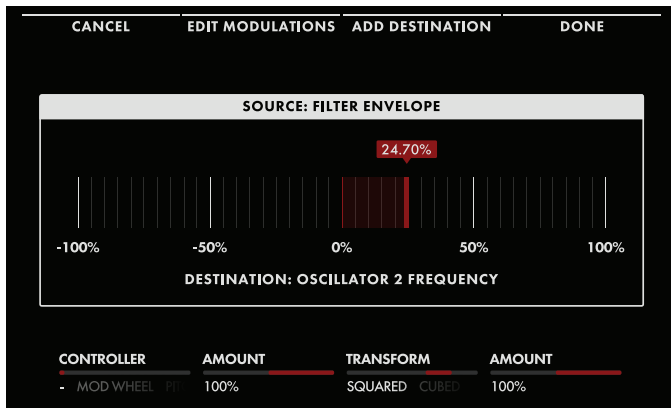
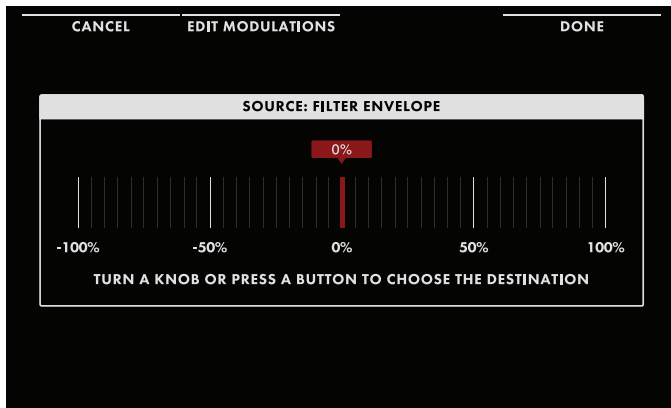

In this example, the Oscillator 2 **FREQUENCY** knob has been selected, and turning the knob will set the modulation amount as shown in the second screen. At this point, pressing the **DONE** Soft Button at the top of the screen will complete the modulation routing, or the **CANCEL** Soft Button can be used to exit this modulation screen without making the modulation route complete. The functions of the additional Soft Knobs and Soft Buttons are discussed in the **MODULATION** section.

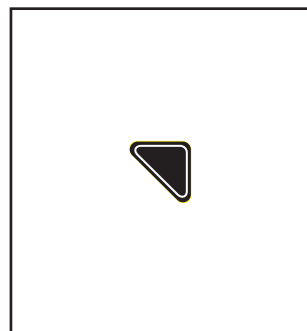

### ENVELOPE MORE PAGE

Pressing the associated triangular **MORE** button in the upper right corner of any Envelope will reveal a second level of parameters that can be accessed and modified using the interactive portion of the Center Console. These additional parameters are displayed in the bottom portion of the screen. The left pane offers a visual representation of the Envelope shape. The right pane shows the current value of the Front Panel hardware parameters for this module. Tweaking these panel controls will update their values here.

**NOTE:** Pressing the (now) illuminated **MORE** button will exit the **MORE** page and recall the **HOME** screen.

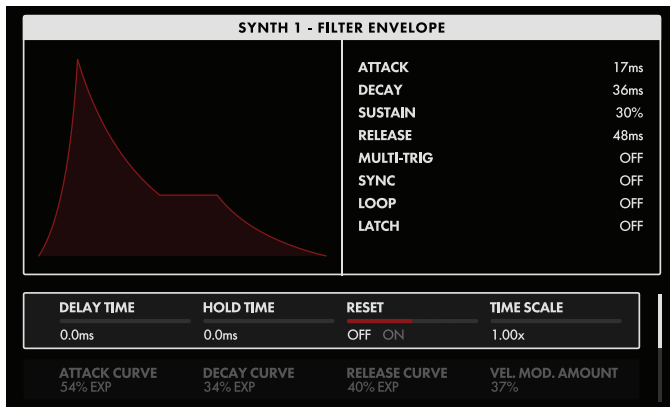

## ENVELOPES *(Continued)*

The onscreen **MORE** page parameters are edited using the four Soft Knobs below the screen.

### CHANGING THE VALUE

Rotate the Soft Knob below the parameter name to change its value. In some cases, the Soft Knob simply turns a function on or off. In other cases, the Soft Knob may choose from a list of values or settings, and in other cases, the Soft Knob is dialing in a value – either absolute or a percentage.

### SELECTING A ROW

The scroll bar at the right edge indicates the current row. Rotate the Master Encoder to the right to highlight the next row of parameters. Rotating the Master Encoder to the left will select a previous row. Again, rotate the Soft Knob below the parameter to change its value.

### DELAY TIME *(0 ms to 10 SECONDS)*

Not to be confused with the **DECAY KNOB**, the DELAY TIME parameter specifies how soon the Attack will begin after a key is pressed (or a gate is opened). Normally, this value will be 0 ms, and the envelope Attack will begin instantaneously.

### HOLD TIME *(0 ms to 10 SECONDS)*

The HOLD TIME parameter pauses the Envelope at the peak of the Attack stage for a specific period of time before the Decay stage begins.

***TIP:** Setting the HOLD TIME of the Amplifier Envelope to about 10 to 100 ms can simulate a taste of the classic Minimoog “envelope clipping” to deliver an extra bite or edge to the sound.*

### RESET *(OFF, ON)*

This parameter applies to the EG Attack stage, when either the **MONO** or **UNISON** buttons in the Polyphony Module are lit, and the EG **MULTI TRIG** button is On. When the RESET function is On, each new note played will cause the Envelope to begin again, resetting the Attack stage to zero. When RESET is Off, a new note played Legato style will apply the Envelope’s current value as the starting point for the Attack stage.

### TIME SCALE *(10% to 100% to 1000%)*

Changing the TIME SCALE can provide Envelopes with longer or shorter durations while maintaining the timing ratios established by the Delay, Attack, Hold, Decay, and Release settings. Using the center value of 100% does not alter the TIME SCALE.

***TIP:** Using Velocity or Keyboard Tracking as a modulation source for this parameter can provide increased articulation over all five Envelope Time parameters.*

***TIP:** Any Envelope stage having a time value = MIN will be unaffected by changes to the Time Scale parameter.*

## **ENVELOPES** *(Continued)*

### **ATTACK CURVE** *(100% LOG to LINEAR to 100% EXP)*

Each Envelope can specify a particular type of curve for each stage. With a value of 100% LOG, the Attack curve will have a Logarithmic shape. When the value reaches LINEAR, the resulting Attack curve will be a straight line. With a value of 100% EXP, the Attack curve will take on an Exponential shape.

### **DECAY CURVE** *(100% LOG to LINEAR to 100% EXP)*

Each Envelope can specify a particular type of curve for each stage. With a value of 100% LOG, the Decay curve will have a Logarithmic shape. When the value reaches LINEAR, the resulting Decay curve will be a straight line. With a value of 100% EXP, the Decay curve will take on an Exponential shape.

### **RELEASE CURVE** *(100% LOG to LINEAR to 100% EXP)*

Each Envelope can specify a particular type of curve for each stage. With a value of 100% LOG, the Release curve will have a Logarithmic shape. When the value reaches LINEAR, the resulting Release curve will be a straight line. With a value of 100% EXP, the Release curve will take on an Exponential shape.

***TIP:** Exponential curves (100% EXP) can appear to affect the Envelope speed, especially when applied to Release times, so it is often necessary to increase the Release time to compensate. When striving for a truly long Release time (nearing the full 10 second maximum), setting the Time Scale to around 9x or so may be required.*

***NOTE:** The Envelope display in the left part of the display will reflect the Attack, Decay, and Release curve assignments made above.*

### **VEL MOD AMT** *(-100% to 0 to +100%)*

Velocity information from the keyboard can be used to modulate the Envelope amplitude by specifying the Velocity Modulation Amount. Note that this parameter can be given either a positive or negative value. As the value of this parameter approaches 100%, notes played with less velocity generate lower Envelope output levels. Conversely, as the value of this parameter approaches -100%, notes played with greater velocity generate lower Envelope output levels. The default value is zero.

## LOW FREQUENCY OSCILLATORS

Just as the Oscillator is the primary sound source found in a synthesizer, the Low Frequency Oscillator (LFO) is often the primary source for adding modulation. Whenever one synthesizer module influences the behavior of another module, that is modulation. As the name suggests, LFOs are Oscillators that have a low-frequency operating range. LFOs are ideal for introducing a controlled, cyclic modulation that can be used for adding vibrato (modulating the pitch of the oscillator), for example, but it goes far beyond that. Moog One provides four independent LFOs that deliver extensive modulation control, plus a host of modulation parameters that open new avenues for creative sound design. Plus, each LFO can be individually sync'd to different timing divisions of the Master Clock for an astounding polyrhythmic performance.

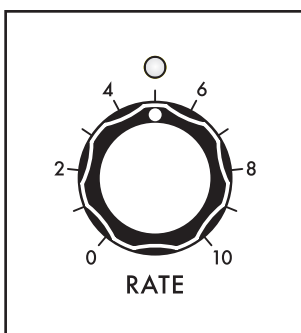

### **RATE** (0 to 10)

The **RATE** knob sets the speed of the LFO; slower values to the left, faster values to the right. The range of available frequencies is determined by the RANGE parameter in the LFO More page. Additionally, when the LFO is sync'd, the **RATE** knob is used to select a timing division of the Master Clock. The **RATE** knob LED will flash at the current setting.

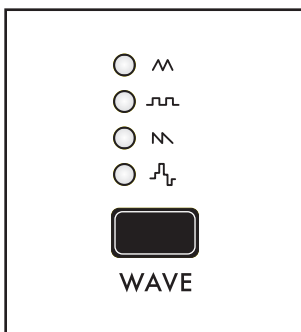

### **WAVE** (TRIANGLE, PULSE, SAWTOOTH, S-H)

The **WAVE** button cycles through the four categories of LFO waveforms: Triangle / Sine, Pulse, Saw / Ramp, and Sample-Hold / Noise. The final wave shape is determined by the VARIATION parameter found on the LFO MORE page.

### **TRI / SINE** (TRIANGLE to SINE)

This option provides both a Triangle wave and a Sine wave. Changing the value of the VARIATION parameter will provide a transition between the Triangle wave and a Sine wave.

### **PULSE**

With Pulse selected, changing the value of the VARIATION parameter in turn changes the pulse width, or duty cycle, of the wave.

### **SAW / RAMP** (SAWTOOTH to RAMP)

This option provides both a Sawtooth wave and a Ramp wave. Changing the value of the VARIATION parameter will provide a transition between the Sawtooth wave and a Ramp wave.

### **S&H / NOISE** (SAMPLE & HOLD to NOISE)

For the S&H (Sample & Hold) wave, changing the value of the VARIATION parameter will provide a transition between the S&H wave and Noise.

## LOW FREQUENCY OSCILLATORS *(Continued)*



### **DEST** *(DESTINATION)*

The **DEST** (Destination) button provides a quick and easy way to establish a modulation route using the LFO as the source. Once the **DEST** button is pressed, the Modulation Quick Assign screen will open in the Center Console Display.

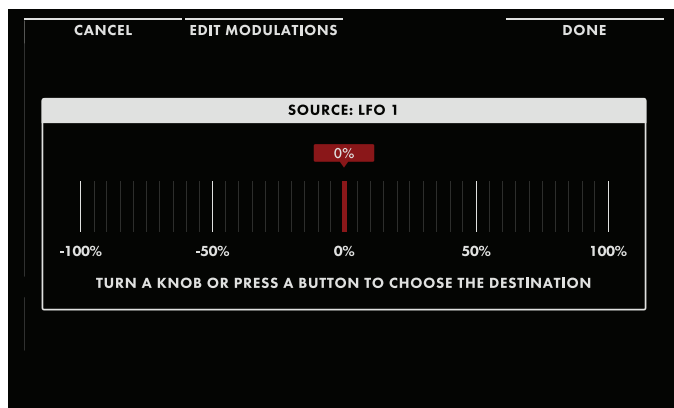

The next Front Panel parameter that is touched or tweaked will become the modulation destination. In this example, the Oscillator 2 **FREQUENCY** knob has been selected, and turning the knob will set the modulation amount as shown in the second screen.

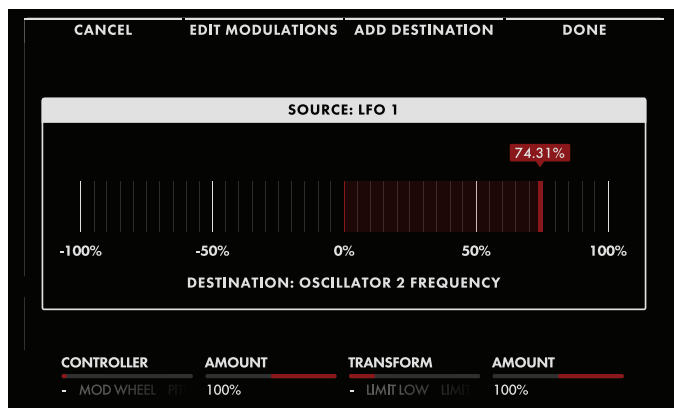

At this point, pressing the DONE Soft Button at the top of the screen will complete the modulation routing, or the CANCEL Soft Button can be used to exit this modulation screen without making the modulation route complete. The functions of the additional Soft Knobs and Soft Buttons are discussed elsewhere, in the MODULATION section.

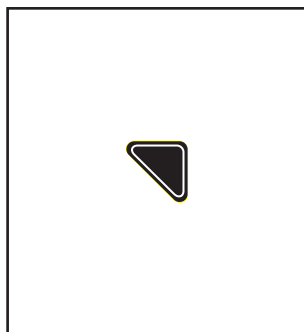

### **LFO MORE PAGE**

Pressing the triangular **MORE** button in the upper right corner of any LFO module will reveal its second level of parameters that can be accessed and modified using the interactive portion of the Center Console. These additional parameters are displayed in the bottom portion of the screen. The left pane shows the LFO wave shape as determined by the LFO **WAVE** button on the Front Panel and the **VARIATION** parameter described below. The right pane shows the current values of the Front Panel parameters for this module. Tweaking these Front Panel controls will update their values here.

**NOTE:** Pressing the (now) illuminated **MORE** button will exit the **MORE** page and recall the **HOME** screen.

## LOW FREQUENCY OSCILLATORS *(Continued)*

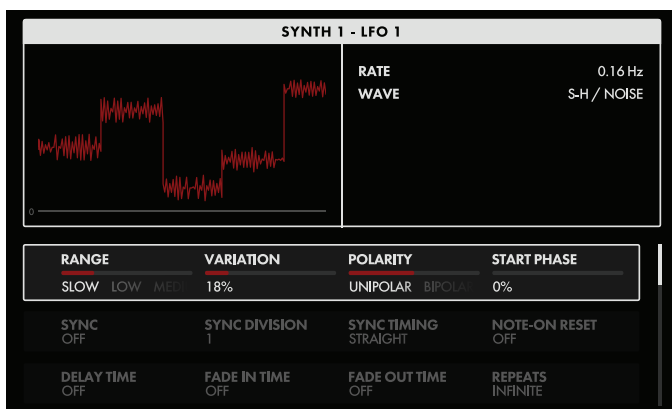

The onscreen **MORE** page parameters are edited using the four Soft Knobs below the screen.

### CHANGING THE VALUE

Rotate the Soft Knob below each parameter name to change its value. In some cases, the Soft Knob simply turns a function on or off. In other cases, the Soft Knob may choose from a list of values or settings, and in other cases, the Soft Knob is dialing in a value – either absolute or a percentage.

### SELECTING A ROW

The scroll bar at the right edge indicates the current row. Rotate the Master Encoder to the right to highlight the next row of parameters. Rotating the Master Encoder to the left will select a previous row. Again, rotate the Soft Knob below the parameter to change its value.

### RANGE *(SLOW, LOW, MEDIUM, HIGH)*

Each LFO has a frequency range from 0.001Hz to 1 kHz. In order to make it easier to dial in just the right rate, the range is divided into four sections.

#### **SLOW**

0.001 Hz to 1 Hz

#### **LOW**

0.01 Hz to 10 Hz

#### **MEDIUM**

0.1 Hz to 100 Hz

#### **HIGH**

1.0 Hz to 1 kHz

### VARIATION *(0% to 100%)*

Pressing an LFO **WAVE** button on the Front Panel selects from a series of variable LFO wave shapes. The VARIATION parameter provides a smooth and continuous transition from one (0%) to the other (100%). The resulting wave shape is shown in the left pane of each LFO MORE page.

### TRIANGLE *(TRI / SIN)*

Triangle forms a symmetrical wave, with equal rise and fall times. The VARIATION parameter provides a continuous transition from Triangle (0%) to Sine (100%). Sine replaces the pointed peaks and valleys of the Triangle with a smoother curve.

### PULSE

With Pulse selected, the VARIATION parameter provides a continuous change in pulse width, or duty cycle, from 0% to 100%

**TIP:** When applying the VARIATION parameter to a Pulse wave, 0% is “always off” and 100% is “always on” so if you don’t hear any changes from an LFO that is set to the Pulse wave, try changing the VARIATION parameter to some mid-range value.



## LOW FREQUENCY OSCILLATORS *(Continued)*

### **SAWTOOTH** *(SAW / RAMP)*

The relationship between a Sawtooth Wave and Ramp Wave is based on the ratio of rise time to fall time. The Sawtooth has an immediate rise and a slower fall, the Ramp Wave has a gradual rise and an immediate fall. The transition from Sawtooth (0%) to Ramp (100%) is determined by the VARIATION parameter.

### **S-H** *(S-H / NOISE)*

Sample & Hold takes an instantaneous sample (reading) of the noise signal and holds it until the next clock cycle, when another sample is taken, etc. The Noise LFO is a continuously-changing random value, derived from white noise. The transition from Sample & Hold (0%) to Noise (100%) is determined by the VARIATION parameter.

### **POLARITY** *(UNIPOLAR, BIPOLAR)*

When the Polarity is set to Unipolar, the lowest point on the wave cycle is defined as having a value equal to zero; all values above will be in the positive domain. With Polarity set to Bipolar, the centerline of the wave is defined as having a value equal to zero; values above the center line will be in the positive domain, values below this centerline will be in the negative domain.

### **START PHASE** *(0% to 100%)*

This parameter determines at what position in the LFO's cycle it will begin, each time the LFO cycle is reset. The LFO will reset with each new note-on event if the NOTE-ON RESET parameter is set to On, or if the value of the Repeats parameter is set to an integer. The LFO will also reset to this Start Phase position on Master Clock Start, if the LFO SYNC parameter is set to On.

### **SYNC** *(ON, OFF)*

When Sync is Off, the LFO is free to run at its own speed and clock rate. When Sync is On, the LFO and Master Clock are synchronized, and the Master Clock determines the LFO Rate.

**NOTE:** *When Sync is selected here, rotating the LFO **RATE** knob on the Front Panel will select quantized clock divisions (see below) of the Master Clock.*

### **SYNC DIVISION** *(64, 32, 16, 8, 4, 2, 1, 1/2, 1/4, 1/8, 1/16, 1/32, 1/64)*

When Sync'd, the Master Clock provides a tempo base; divisions of that Master Clock are used to set the LFO Rate. Changing the Sync Division specifies the timing in terms of quarter-note beats.

### **SYNC TIMING** *(STRAIGHT, DOTTED, TRIPLET)*

When Sync'd, Sync Timing provides a further modification of the Master Clock. Here the timing of each note played can be set relative to the Master Clock.

#### **STRAIGHT**

The timing of each step is played as specified by the Sync Division.

#### **DOTTED**

The timing of each step is modified to play as a dotted note, or at 1.5 x the value specified by the Sync Division.

#### **TRIPLET**

The timing of each step is modified to play as if it were one note in a triplet, or at 2/3rds of the value specified by the Sync Division.

### **NOTE-ON RESET** *(OFF, ON)*

With this parameter set to On, the LFO begins a new cycle with each new note on-event, beginning from the value specified in the START PHASE parameter.

## LOW FREQUENCY OSCILLATORS *(Continued)*

### **DELAY TIME** *(OFF, 0ms to 10s)*

This parameter sets up a timing delay, or interval, before the LFO signal begins.

### **FADE IN TIME** *(OFF, 0ms to 10s)*

This parameter controls how much time is need for the LFO intensity to rise from zero to its maximum level. The Fade In time begins *after* the Delay Time is complete.

### **FADE OUT TIME** *(OFF, 0ms to 10s)*

This parameter controls how much time is need for the LFO intensity to fall from its maximum level to 0. The Fade Out time begins *after* the Delay Time and the Fade-In stages are complete.

### **REPEATS** *(INFINITE, 1 - 32)*

Setting an integer value for this parameter will specify an exact number of full cycles that will be completed by the LFO, after Note On. Once that value has been reached, the LFO will wait for the next note-on command and begin all over.

***TIP:** The DELAY TIME, FADE IN TIME, FADE OUT TIME, and REPEATS parameters can be used together to make some exciting performance modulation happen as part of the sound design of your Preset, without needing to use a free hand to operate a modulation controller. For example, you could have an LFO wait 2 seconds to fade in and then fade out on a wide vibrato that is applied 8 times to a sustained note(s).*

### **SMOOTHING** *(0% to 100%)*

By selecting smoothing, a single-pole (-6 dB per Octave) low-pass filter is applied to the LFO wave shape. As the Smoothing value is increased, the Cutoff Frequency is lowered, limiting the changes in the LFO signal. Smoothing is most noticeable at slower LFO rates, and with the S-H / Noise and Pulse wave shapes.

## VCA AND OUTPUT

The VCA module and the OUTPUT module may appear to be similar, but their functions are quite different. In short, the panel controls of the VCA module consist of a **LEVEL** knob and a **PAN** knob. Their function affects only the active Synth(s) that has been selected using the Panel Focus buttons: **SYNTH 1**, **SYNTH 2**, and **SYNTH 3**. Their purpose is to set the level and panning of the active Synth within the stereo MAIN OUT and/or SUB OUT mixes. The panel controls of the MASTER OUT module, on the other hand, are used to adjust the listening level of the entire Moog One, and are unaffected by the loading of Presets and Timbres. Both modules are equipped with a **MORE** button that reveals a second parameter layer, where their differences may become more apparent.

## VCA

VCA stands for Voltage Controlled Amplifier. Before it can be heard, the sound being created by Moog One must pass through an amplifier circuit to bring it to an appropriate output level. This amplifier circuit is under voltage control, meaning that the amplifier parameters can be controlled via a modulation source, and are saved as part of the active Synth.

## VCA (Continued)

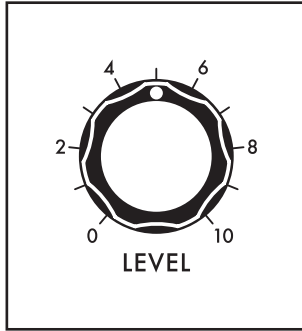

### LEVEL (0 to 10)

The **LEVEL** knob sets the volume of the active Synth in the Main and Sub Outputs.

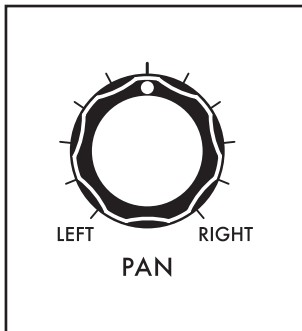

### PAN (LEFT to RIGHT)

The **PAN** knob sets the stereo pan position of the active Synth in the Main and Sub stereo output mixes. Rotating the knob to left pans the Synth to the left; rotating the knob to the right pans the Synth to the right. In the center position, the Synth is panned equally between the left and right outputs.

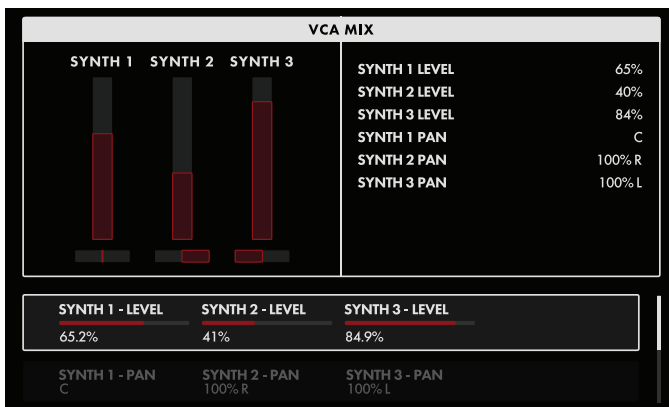

### VCA MORE PAGE

Pressing the triangular **MORE** button in the upper right corner of the VCA module will open the VCA MORE page. The VCA MORE page conveniently places the Level and Pan controls of all three Synths together on one page, making it easy to set the right mix. Panning adjusts the placement of the sound in the stereo field when using the **MAIN OUT** Left and Right jacks or the **SUB OUT** Left and Right jacks. The left pane offers a visual representation of the Level and Pan settings of each Synth. The right pane shows the current

value of the Front Panel hardware parameters for this module. The Front Panel controls can only adjust the active Synth. Using the parameters at the bottom of the screen allows all Synths to be adjusted here. In either case, the values shown in the right pane will be update when the controls are edited.

**NOTE:** Pressing the (now) illuminated **MORE** button will exit the MORE page and recall the HOME screen.

The onscreen **MORE** page parameters are edited using the four Soft Knobs below the screen.

### CHANGING THE VALUE

Rotate the Soft Knob below each parameter name to change its value. In some cases, the Soft Knob simply turns a function on or off. In other cases, the Soft Knob may choose from a list of values or settings, and in other cases, the Soft Knob is dialing in a value – either absolute or a percentage.

### SELECTING A ROW

The scroll bar at the right edge indicates the current row. Rotate the Master Encoder to the right to highlight the next row of parameters. Rotating the Master Encoder to the left will select a previous row. Again, rotate the Soft Knob below the parameter to change its value.

**SYNTH 1 - LEVEL** (0% to 100%)

Turning the Soft Knob to the left decreases the Level of Synth 1. Turning the Soft Knob to the right increases the Level of Synth 1. The Level Indicator in the left pane will move, and the corresponding value in the right pane will change as well.

**SYNTH 2 - LEVEL** (0% to 100%)

Turning the Soft Knob to the left decreases the Level of Synth 2. Turning the Soft Knob to the right increases the Level of Synth 2. The Level Indicator in the left pane will move, and the corresponding value in the right pane will change as well.

**SYNTH 3 - LEVEL** (0% to 100%)

Turning the Soft Knob to the left decreases the Level of Synth 3. Turning the Soft Knob to the right increases the Level of Synth 3. The Level Indicator in the left pane will move, and the corresponding value in the right pane will change as well.

**SYNTH 1 - PAN** (100% L to C to 100% R)

Turning the Soft Knob to the left will pan the sound of Synth 1 to the left. Turning the Soft Knob to the right will pan the sound of Synth 1 to the right. A value of C (for Center) places the sound of Synth 1 in the center of the stereo mix. The Pan Indicator in the left pane will move, and the corresponding value in the right pane will change as well.

**SYNTH 2 - PAN** (100% L to C to 100% R)

Turning the Soft Knob to the left will pan the sound of Synth 2 to the left. Turning the Soft Knob to the right will pan the sound of Synth 2 to the right. A value of C (for Center) places the sound of Synth 2 in the center of the stereo mix. The Pan Indicator in the left pane will move, and the corresponding value in the right pane will change as well.

**SYNTH 3 - PAN** (100% L to C to 100% R)

Turning the Soft Knob to the left will pan the sound of Synth 3 to the left. Turning the Soft Knob to the right will pan the sound of Synth 3 to the right. A value of C (for Center) places the sound of Synth 1 in the center of the stereo mix. The Pan Indicator in the left pane will move, and the corresponding value in the right pane will change as well.

**SYNTH 1 - SPREAD** (0% to 100%)

This parameter determines the width, or the amount of stereo spread created by voices played in Synth 1. The pan position specified by the Synth 1 Pan parameter is the center of the stereo spread. With a value of 0%, no Spread is applied and all voices will be subject to the pan position specified by the Synth 1 Pan parameter. Rotate the Soft Knob to the right to increase the amount of stereo spread applied, dynamically panning individual voices in the stereo field up to the specified amount.

**SYNTH 2 - SPREAD** (0% to 100%)

This parameter determines the width, or the amount of stereo spread created by voices played in Synth 2. The pan position specified by the Synth 2 Pan parameter is the center of the stereo spread. With a value of 0%, no Spread is applied and all voices will be subject to the pan position specified by the Synth 2 Pan parameter. Rotate the Soft Knob to the right to increase the amount of stereo spread applied, dynamically panning individual voices in the stereo field up to the specified amount.

**SYNTH 3 - SPREAD** (0% to 100%)

This parameter determines the width, or the amount of stereo spread created by voices played in Synth 3. The pan position specified by the Synth 3 Pan parameter is the center of the stereo spread. With a value of 0%, no Spread is applied and all voices will be subject to the pan position specified by the Synth 3 Pan parameter. Rotate the Soft Knob to the right to increase the amount of stereo spread applied, dynamically panning individual voices in the stereo field up to the specified amount.

## OUTPUT

The Output module contains two volume knobs, one to control the **MASTER VOLUME** (**MAIN L/R** outputs), and one to control the **HEADPHONES** output level. Each knob functions independently; turning the **MASTER VOLUME** down and the **HEADPHONES** level up allows Moog One settings and sounds to be cued up, or auditioned privately without the need to change any external mixer settings or connections. The **MASTER VOLUME** and **HEADPHONES** knobs are global for the entire Moog One. Unlike every other knob on the Front Panel, these knobs always display their true value in a “what you see is what you get” manner.

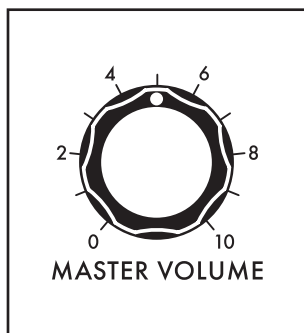

### **MASTER VOLUME** (0 to 10)

The **MASTER VOLUME** knob controls the **MAIN L/R** output level of Moog One. Higher values will have a higher volume level.

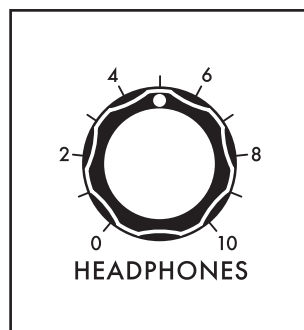

### **HEADPHONES** (0 to 10)

Moog One provides two identical headphone jacks, located on the front edge of the Left Hand Controller panel. This **HEADPHONES** knob controls the volume level of the **HEADPHONES** jacks, which are not affected by the **MASTER VOLUME** knob. This allows you to check or tweak a Preset with headphones on stage without allowing the audience to hear it until you're ready to turn up the **MASTER VOLUME** knob.

## OUTPUT MORE PAGE

Pressing the triangular **MORE** button in the upper right corner of the OUTPUT module will reveal a second level of parameters that can be accessed and modified using the interactive portion of the Center Console. These additional parameters are displayed in the bottom portion of the screen. The left pane displays output assignments for each Synth and for each of the **EXT. INPUT** jacks, as well as the volume level of each output. The right pane shows the current value of the Front Panel hardware parameters for this module. Tweaking these panel controls will update their values here.

The **MORE** parameters of the global OUTPUT module designate the routing for each Synth in the current Preset. Output Routing for the Insert channels is one-to-one, meaning each Synth can only be assigned to one Insert at a time, and each Insert can only host one Synth at a time.

**NOTE:** Pressing the (now) illuminated **MORE** button will exit the **MORE** page and recall the **HOME** screen.

## OUTPUT *(Continued)*

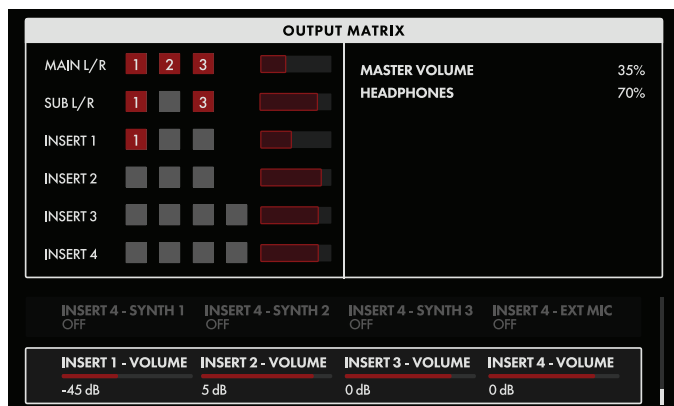

The onscreen **MORE** page parameters are edited using the four Soft Knobs below the screen.

### CHANGING THE VALUE

Rotate the Soft Knob below the parameter name to change its value. In some cases, the Soft Knob simply turns a function on or off. In other cases, the Soft Knob may choose from a list of values or settings, and in other cases, the Soft Knob is dialing in a value – either absolute or a percentage.

### SELECTING A ROW

The scroll bar at the right edge indicates the current row. Rotate the Master Encoder to the right to highlight the next row of parameters. Rotating the Master Encoder to the left will select a previous row. Again, rotate the Soft Knob below the parameter to change its value.

#### MAIN - SYNTH 1 *(OFF, ON)*

Setting this parameter to On will route Synth 1 to the **MAIN L** and **MAIN R** Outputs.

#### MAIN - SYNTH 2 *(OFF, ON)*

Setting this parameter to On will route Synth 2 to the **MAIN L** and **MAIN R** Outputs.

#### MAIN - SYNTH 3 *(OFF, ON)*

Setting this parameter to On will route Synth 3 to the **MAIN L** and **MAIN R** Outputs.

#### SUB - SYNTH 1 *(OFF, ON)*

Setting this parameter to On will route Synth 1 to the **SUB L** and **SUB R** Outputs on the Rear Panel.

#### SUB - SYNTH 2 *(OFF, ON)*

Setting this parameter to On will route Synth 2 to the **SUB L** and **SUB R** Outputs on the Rear Panel.

#### SUB - SYNTH 3 *(OFF, ON)*

Setting this parameter to On will route Synth 3 to the **SUB L** and **SUB R** Outputs on the Rear Panel.

#### SUB VOLUME *(-96 dB to 0 dB to +22 dB)*

This parameter allows the output volume of the **SUB L** and **SUB R** Outputs to be set independently of the **MAIN L** and **MAIN R** Outputs.

#### INSERT 1 - SYNTH 1 *(OFF, ON)*

Setting this parameter to On will route Synth 1 to the **INSERT 1** buss.

#### INSERT 1 - SYNTH 2 *(OFF, ON)*

Setting this parameter to On will route Synth 2 to the **INSERT 1** buss.

#### INSERT 1 - SYNTH 3 *(OFF, ON)*

Setting this parameter to On will route Synth 3 to the **INSERT 1** buss.

## **OUTPUT** *(Continued)*

### **INSERT 2 - SYNTH 1** *(OFF, ON)*

Setting this parameter to On will route Synth 1 to the **INSERT 2** buss.

### **INSERT 2 - SYNTH 2** *(OFF, ON)*

Setting this parameter to On will route Synth 2 to the **INSERT 2** buss.

### **INSERT 2 - SYNTH 3** *(OFF, ON)*

Setting this parameter to On will route Synth 3 to the **INSERT 2** buss.

### **INSERT 3 - SYNTH 1** *(OFF, ON)*

Setting this parameter to On will route Synth 1 to the **INSERT 3** buss.

### **INSERT 3 - SYNTH 2** *(OFF, ON)*

Setting this parameter to On will route Synth 2 to the **INSERT 3** buss.

### **INSERT 3 - SYNTH 3** *(OFF, ON)*

Setting this parameter to On will route Synth 3 to the **INSERT 3** buss.

### **INSERT 3 - EXT 1/4** *(OFF, ON)*

Setting this parameter to On will route an audio signal arriving at the **EXT INPUT 1/4"** jack to the **INSERT 3** buss.

### **INSERT 4 - SYNTH 1** *(OFF, ON)*

Setting this parameter to On will route Synth 1 to the **INSERT 4** buss.

### **INSERT 4 - SYNTH 2** *(OFF, ON)*

Setting this parameter to On will route Synth 2 to the **INSERT 4** buss.

### **INSERT 4 - SYNTH 3** *(OFF, ON)*

Setting this parameter to On will route Synth 3 to the **INSERT 4** buss.

### **INSERT 4 - EXT XLR** *(OFF, ON)*

Setting this parameter to On will route an audio signal arriving at the **EXT INPUT XLR** jack to the **INSERT 4** buss.

### **INSERT 1 - VOLUME** *(-96 dB to 0 dB to +22 dB)*

This parameter allows the volume of the **INSERT 1** Output to be set independently.

### **INSERT 2 - VOLUME** *(-96 dB to 0 dB to +22 dB)*

This parameter allows the volume of the **INSERT 2** Output to be set independently.

### **INSERT 3 - VOLUME** *(-96 dB to 0 dB to +22 dB)*

This parameter allows the volume of the **INSERT 3** Output to be set independently.

### **INSERT 4 - VOLUME** *(-96 dB to 0 dB to +22 dB)*

This parameter allows the volume of the **INSERT 4** Output to be set independently.

## OUTPUT *(Continued)*

### UNDERSTANDING INSERTS

Inserts are unique in that they can function as both outputs and inputs at the same time. As outputs, they provide a way of allowing each Synth to have its own dedicated output - either for recording and monitoring purposes, or to independently access an external effect processor such as a stereo chorus unit. The inserts also provide an input path, or return, from such an external processor. The monaural output from an external processor is returned to the same insert jack it was sent from, using a 1/4" TRS to dual 1/4" TS insert cable. For an external processor with a monaural input and a stereo output, Moog One can receive the return signals using an adjacent pair of inserts. Odd numbered inserts (**1, 3**) merge the return signal to the **MAIN L** buss, and even numbered insert (**2, 4**) merge the return signal to the **MAIN R** bus. In this way, a monaural signal sent to an external processor can return in stereo using a pair of adjacent insert points (**1 & 2** or **3 & 4**). So the monaural signal sent via **INSERT 1** can be returned in stereo using **INSERT 1** and **INSERT 2**. Further, these adjacent pairs are normalled, so that if nothing is connected to **INSERT 2**, the monaural return signal arriving at **INSERT 1** will be applied to both the **MAIN L** and **MAIN R** busses. The same scenario applies to **INSERT 3** and **INSERT 4**.

Technically, each of the four inserts relies on a single 1/4" TRS jack wired as both a send and a return. The Tip of this Tip/Ring/Sleeve jack is wired as the Send; the signal is then returned to Moog One via the Ring connection of the Tip/Ring/Sleeve jack. Most often, an insert jack will be used with a Y-Configuration Insert Cable (1/4" TRS to dual 1/4" TS) to achieve this functionality.

**NOTE:** *When active, the onboard Synth Effect is applied to each Synth before its signal reaches the output (Tip) of the insert jack.*



## PERFORMANCE SET

A chosen Performance Set makes up to 64 Presets available with just a button press (or two) on the Front Panel. This is a must for live performance, and can be equally useful for organizing sounds at a session. Moog One contains a virtually unlimited number of Performance Sets, but only one Performance Set can be active at any time. Choose a Preset from the active Performance Set by pressing one of the 8 BANK buttons (**A - H**) and one of the 8 PRESET buttons (**1 - 8**) on the Front Panel. Both of the buttons you selected will light to show the active Preset. When selecting a Preset from within the current Bank, just press the appropriate PRESET button.



**TIP:** There is a *SHOW BANK PREVIEW* option available (*SETTINGS / GLOBAL / HARDWARE SETTINGS*). When this function is On, pressing a BANK button will open a screen showing all of the Presets assigned to that Bank.

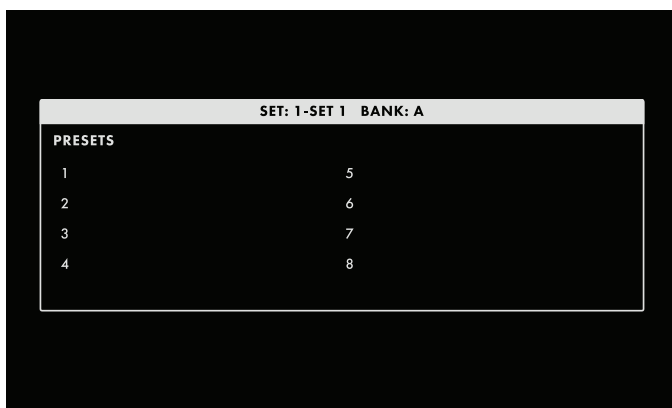

**NOTE:** The Performance Set does not itself provide storage of Presets; instead, the Performance Set saves “pointers” that direct Moog One to recall a specific Preset from memory.

**TIP:** The active BANK (**A - H**) and PRESET (**1 - 8**) buttons will light at full intensity; unselected PRESET buttons will have a softer light. If a PRESET button appears dark (unlit), then no Preset has been assigned to that location.

Performance Sets are stored by number. This provides a consistent order when browsing Performance Sets, and also facilitates remote MIDI Program and Bank selection. In addition, each Performance Set may be given a name, and text notes may be added as well. These notes can be quick reminders such as “Set List for Trio Project” or “Lead Sounds for the Album Overdubbing Session,” etc. Any Preset may be assigned to any Performance Set, and the same Preset may appear in multiple Performance Sets.

### ASSIGNING THE CURRENT PRESET TO THE PERFORMANCE SET

The Performance Set BANK and PRESET buttons can also be used to assign the current Preset to the active Performance Set. First, press the desired BANK button (**A - H**) if it is not already lit. Next, assign the current preset to a Performance Set location by pressing and holding one of the PRESET buttons (**1 - 8**) for about one second. The PRESET button will flash rapidly as confirmation.

## PERFORMANCE SET *(Continued)*

### PERFORMANCE SET MORE PAGES

Pressing the triangular **MORE** button in the upper right corner of the PERFORMANCE SET module will open the CURRENT SET page. The additional BROWSE SETS and ARRANGE SETS pages can be selected using the Soft Buttons above the screen. When in Arrange Sets, An EDIT soft button allows editing of the Name and Notes for the current/selected set.

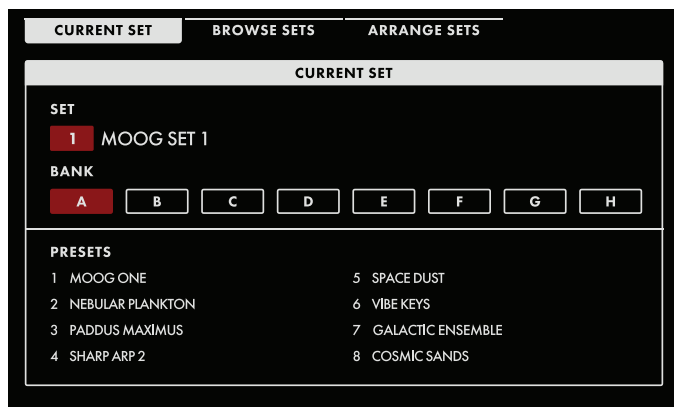

### CURRENT SET

The CURRENT SET page provides the name and number of the active Performance Set under the SET heading. The BANK heading shows which Bank is selected, and the names of all of the Presets in that Bank are shown under the PRESETS heading; the current Preset is highlighted. Turning the Master Encoder selects the next (to the right) or previous (to the left) Preset.

Holding **SHIFT** while turning the Master Encoder allows the highlighted Preset to be moved to a new location within the current Bank. Once the highlighted Preset is in its new location, release the **SHIFT** button; all the other Presets in that Bank will be re-numbered accordingly.

**NOTE:** If a Preset not assigned to the current Performance Set was active before pressing the **MORE** button, then Bank A of the current Performance Set will be selected, but no Preset will be highlighted. The first time you turn the Master Encoder, Preset 1 of the active Performance Set will be selected. After that, the Master Encoder will load Presets normally.

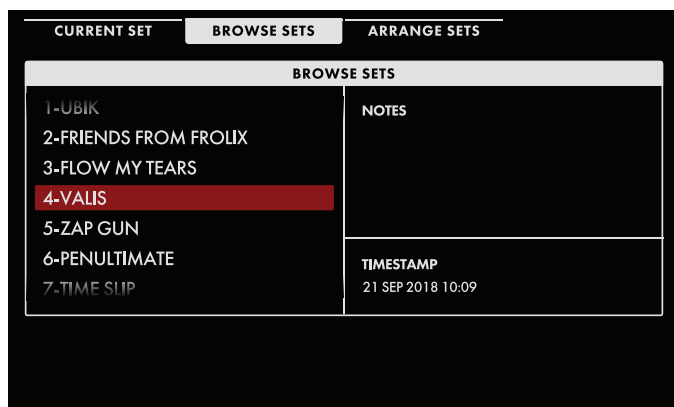

### BROWSE SETS

Use the BROWSE SETS Soft Button to open this screen. The left pane shows a list of all Performance Sets. The upper right pane displays any descriptive or performance notes that have been added; the lower right pane shows the timestamp data, indicating when the Performance Set was last modified or created. The current Performance Set is highlighted.

### LOADING A PERFORMANCE SET USING THE BROWSER

While the BROWSE SETS screen is open, rotate the Master Encoder to select and highlight a different Performance Set; the Performance Set selected here will automatically load and become the active Performance Set.

**NOTE:** Even when a new Performance Set has been selected, the active Preset will not change until a Preset is selected from this new Performance Set.

## PERFORMANCE SET *(Continued)*

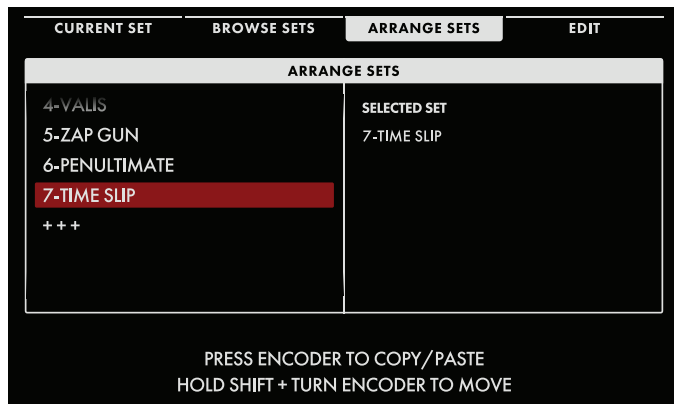

### ARRANGE SETS

Use the ARRANGE SETS Soft Button to open this screen. Here you can add, delete, and rearrange Performance Sets. The left pane shows a list of all Performance Sets. The current Performance Set is highlighted, and appears as the Selected Set in the right pane.

### MOVING A PERFORMANCE SET

Holding **SHIFT** while turning the Master Encoder allows the highlighted Performance Set to be moved to a new location in the list. Once the highlighted Performance Set is in its new location, release the **SHIFT** button.

### COPYING A PERFORMANCE SET

Press down on the Master Encoder to create a copy of the highlighted Performance Set. Turn the Master Encoder to scroll through the list of Performance Sets, then press down on the Master Encoder to place the copied Performance Set in that location. The copied Performance Set is placed between existing Performance Sets - no data is overwritten.

### DELETING A PERFORMANCE SET

Once a Performance Set is highlighted, pressing the **DELETE** button on the Front Panel will delete it. The other performance sets will move to fill the gap.

### ADDING A PERFORMANCE SET

Use the Master Encoder to scroll to the bottom of the Performance Set list until the +++ indicator appears. Highlight this indicator, and the EDIT Soft Button above the screen will change to ADD NEW. Pressing the ADD NEW Soft Button will allow you to enter a name for a new, empty Performance Set. Finally, press the OK Soft Button to complete the process and create your blank Performance Set.

### EDITING A PERFORMANCE SET

The rightmost Soft Button above the screen is labeled EDIT (or ADD NEW, as described above) -- pressing this button opens an editing window where you can edit the Name or Notes for the currently selected set. When finished editing, press either the OK Soft Button to save your changes, or the CANCEL Soft Button to exit without saving changes.

## ENTERING TEXT

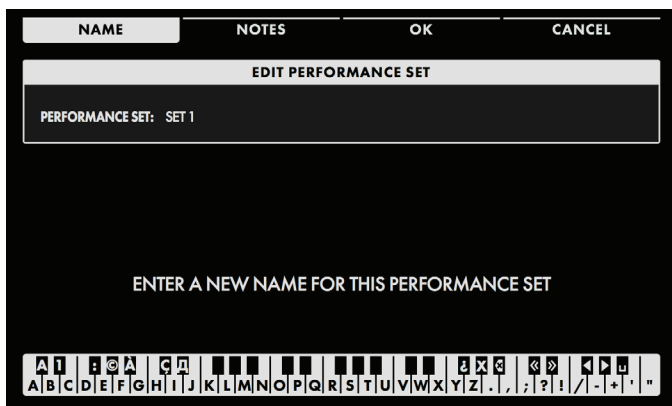

Moog One allows you to enter names and text directly from the keyboard. The white keys (naturals) enter the characters; certain black keys (accidentals) have specific functions.

- Keys C#1 - D#2 select the character set.
- Key F#4 removes the current name and randomly generates a new name.
- Key G#4 clears all the characters in the screen.
- Key A#4 deletes the character to the left of the cursor.
- Keys C#5 and D#5, respectively, change the character immediately preceding the cursor to the previous or next symbol in the current character set, changing an M to an L or an N, for example with a single key press.
- Keys F#5 and G#5 move the cursor left or right, respectively.
- Key A#5 adds a space.

**NOTE:** The note numbers given above relate to the onscreen keyboard, and do not reflect the key's actual MIDI Note number, etc.

**TIP:** You can also enter text directly, using a standard USB keyboard connected to the Moog One **USB HOST** port.

## MASTER CLOCK

The Master Clock provides a base tempo for the entire Moog One, and is measured in BPM (Beats Per Minute). The Master Clock provides a reliable tempo that can be shared amongst various Moog One modules as well as external devices via MIDI and USB. The values of many Moog One parameters are set using units of time - the Arpeggiator speed, the Sequencer tempo, LFO rates, Envelope times, Effect times, etc. These parameters can be set individually and expressed as absolute measures of time, or they can be synchronized to the Moog One Master Clock, and specified as timing divisions of the current BPM. By default, the Sequencer(s) and the Arpeggiator(s) are sync'd to the Master Clock; the LFOs and EGs are not. Selecting an external clock source (MIDI, USB, CV, etc.) will override the Master Clock.

**TIP:** One advantage of using Sync is that by changing just the Master Clock Rate, all of the sync'd parameters will also change, and will remain in step with the Master Clock.

**NOTE:** The current tempo is always displayed in the HOME screen.

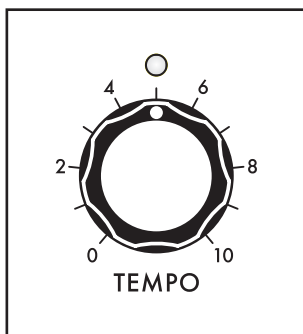

### TEMPO (0 to 10)

This knob sets the tempo for the Master Clock. Turn the **TEMPO** knob to the left to slow down the Master Clock; turn the **TEMPO** knob to the right to speed up the Master Clock. The available range is from 10 BPM to 280 BPM. The LED above the **TEMPO** knob will flash on each beat to visually indicate the tempo.

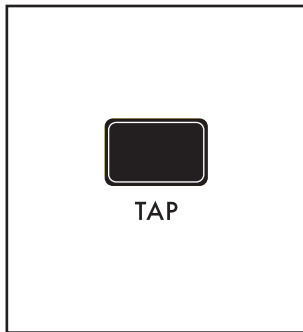

### TAP

The **TAP** button allows the tempo value to be set by feel, as opposed to a number. Tap the **TAP** button a few times at the desired rate to set the tempo. The tempo is set based on the timing between taps. More taps at a consistent rate will produce a more accurate tempo setting.

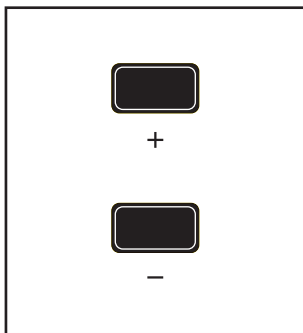

### NUDGE (+ and -)

These buttons are used to perform minor tweaks to the tempo setting in real time. Their function and operation is set using commands found in the Master Clock MORE page.

## MASTER CLOCK MORE PAGE

Pressing the triangular **MORE** button in the upper right corner of the Master Clock module opens a second level of parameters that can be accessed and modified using the interactive portion of the Center Console. The current tempo is displayed in the center of the screen and can be changed by rotating the Master Encoder. Turning the Master Encoder in **SHIFT** mode allows for finer adjustments.

**NOTE:** Pressing the (now) illuminated More button will exit the MORE page and recall the HOME screen.

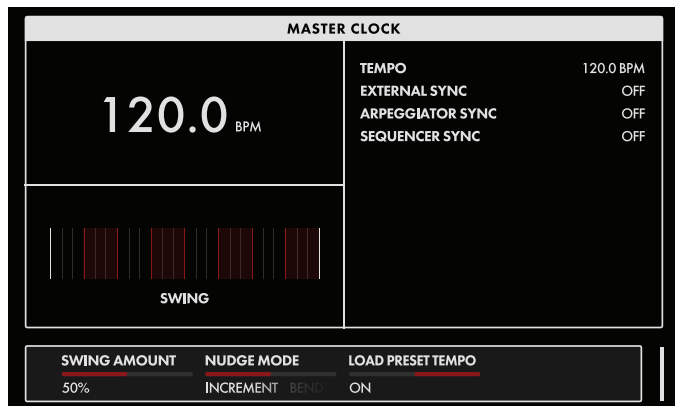

The onscreen MORE page parameters are edited using the soft rotary encoders below the screen.

### CHANGING THE VALUE

Rotate the Soft Knob below the parameter name to change its value. In some cases, the Soft Knob simply turns a function on or off. In other cases, the Soft Knob may choose from a list of values or settings, and in other cases, the Soft Knob is dialing in a value – either an absolute value or a percentage.

### SWING AMOUNT (0% to 50% to 100%)

Swing changes the timing relationship between the on-beat and the off-beat. The on-beat is always strictly aligned to the clock. Adding swing allows the off-beat to come in a touch later and be a bit shorter, or to come in a bit early and hold a touch longer. Swing beats, shuffles, and other rhythmic variations can be created this way. Swing is expressed as a percentage measuring how much time the on-beat occupies, relative to the total duration of an on-beat plus an off-beat.

Below the tempo value is a type of bar graph showing the amount of Swing being applied. In this bar graph, each white box represents an on-beat, and each grey box represents the complementary off-beat. As you rotate the Soft Knob to change the amount of Swing, the relationship between these two boxes will change to indicate how Swing is being applied. In the center position (50%), no swing is being applied to the beat.

### NUDGE MODE (INCREMENT, BEND)

This parameter determines the behavior of the + and - buttons on the Front Panel.

#### INCREMENT

In this mode, each press of the + button will slightly increase the Master Clock tempo, and each press of the - button will slightly decrease the tempo of the Master Clock. This is convenient way to fine tune the tempo setting.

#### BEND

In this mode, holding the + button will momentarily increase the Master Clock tempo by a small amount until the button is released. Holding the - button will momentarily decrease the Master Clock tempo by a small amount until the button is released. When either button is released the tempo returns to its original value. Borrowed from the DJ world, this technique is great for beat matching on the fly.

### LOAD PRESET TEMPO (ON, OFF)

When this parameter is set to On, loading a Preset will also load the tempo that was saved with the Preset. In this way, calling up a Preset will automatically call up the correct and saved tempo for your performance. When this parameter is Off, the current tempo will be used.

## VOICE ALLOCATION *(HOLD/CHORD/POLYPHONY)*

Moog One uses a number of sophisticated elements to make the most of the available voices. Grouped together in one area of the Front Panel, these features include the **HOLD** button, the CHORD functions, and the POLYPHONY module.

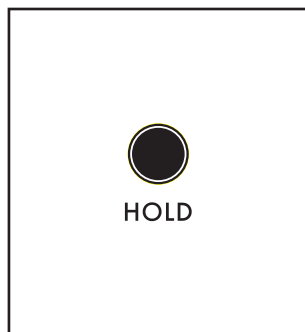

### **HOLD**

The **HOLD** button behaves in much the same way as a sustain pedal – but with a few important differences. When the **HOLD** button is set to On (lit), notes being held when the button was pressed will continue to sound. If new notes are added in a legato style – that is, they are played while other notes are still held – these new notes will be added to the current stack of held notes. If new notes are added in a non-legato fashion, where all of the notes have been released before the new notes are played, the previous notes will stop sounding, and these new non-legato notes will take their place. The **HOLD** button also acts as a latch for the Arpeggiator.

**NOTE:** The **HOLD** button and the Sustain pedal can interact in the following way. If the **HOLD** button is On and the Sustain pedal is also being held (On) then playing new non-legato notes will not clear the previously held notes, they will simply be added to the sustained notes.

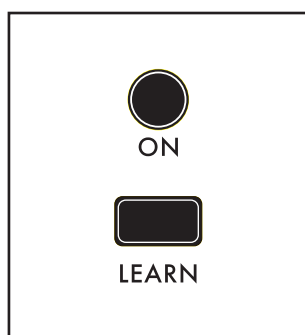

### **CHORD**

Using the CHORD function – often called Chord Memory – allows multiple notes to be stacked on a single key. In turn, each key will also play a stack of notes pitched at those same intervals. If the CHORD function is set to a major triad, every individual key will play a major triad – with the root being the pitch of the key itself. The choice of notes is totally up to the user; it need not be a traditional chord at all.

**TIP:** The CHORD function offers a massive sound with very little effort, but it also can quickly chew up polyphony. Remember that, with the Moog One three oscillator architecture, you can also set up the Oscillators' tunings to play a major triad on each key while using only a single voice. That said, there are many situations where the CHORD function is the way to go.

In the Moog One architecture, the CHORD function is the last module to be presented with note values. The priority runs from [Notes played on the keyboard or via MIDI] to [notes generated by the Arpeggiator] to [interval values saved with the Chord Memory]. This means that every note generated by the Arpeggiator (or Sequencer, for that matter) is in turn fed into the CHORD function, with every arpeggiated or sequenced note playing back as a chord. This makes the Chord feature even more powerful.

### **USING THE CHORD FUNCTION**

Press the **LEARN** button to turn on the Chord Learn function (the **LEARN** button will light). To create a chord, play any series of notes. The first note you play will clear the Chord Learn function and will also set the root note. When you are finished adding notes to your chord, press the **LEARN** button a second time (the button will go dark) to turn the Chord Learn function off. Now, when the CHORD button is turned On, each note will play a transposed version of that chord. One of the Moog One Global settings is the Silent Learn option, which mutes the active synth while the Chord Learn function is On, allowing the chord to be entered in a live venue without the audience hearing this take place. The flip side is that the performer can't hear it either. Both the chord created using the **LEARN** button and the state of the CHORD button (On/Off) are saved per Synth.

**TIP:** When entering a chord, Moog One will recognize the first note entered as the Root note; in this way you can enter a chord using an inversion, and it will still be transposed correctly.

## POLYPHONY

It is polyphony that allows Moog One to play multiple keys at the same time and have them all sound. All polyphonic synthesizers – including Moog One – have a finite number of voices. This module controls the ways to maximize performance by allocating voices effectively. But it's not only about polyphony. Monophonic, or single-note-at-a-time synthesizer playing, has a style all its own, and parameters found here can make the most of those performances as well.

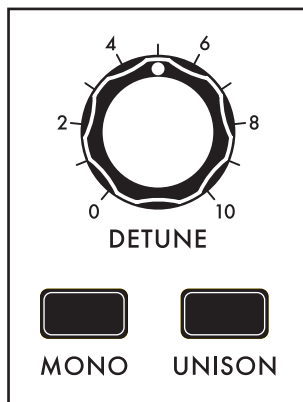

### **MONO** (ON/LIT, OFF/UNLIT)

This button acts as a toggle, switching the active Synth between the Monophonic mode (lit) and Polyphonic mode (unlit). Each mode has additional parameters to define behavior, voice allocation, etc.

### **UNISON** (ON/LIT, OFF/UNLIT)

When **UNISON** button is lit, all of the available voices will play whenever possible, dividing the total number of voices by the number of keys being played, and stacking themselves accordingly. These stacked analog voices can add fullness and depth. For example, if the current Synth is set to a POLY COUNT (MORE page parameter) of eight voices, playing one note will sound eight stacked voices. Adding a second note will reallocate four voices to a Unison stack on the new note, and four voices will continue to play in a Unison stack on the already held note, etc.

**NOTE:** Use the **UNISON COUNT** parameter in the Polyphony MORE page to limit and specify the number of voices being stacked, per note.

### **DETUNE** (0 to 10)

When the **UNISON** button is On/Lit, rotating this knob to the right will apply higher levels of detuning to the stacked Unison voices. The available voices are detuned symmetrically on either side of the original pitch, keeping it as the tonal center of the stacked voices. Not all voices are detuned by the same amount, increasing the fullness of the effect. This knob sets the maximum derivation from the original pitch.

When the **UNISON** button is Off/Unlit, the **DETUNE** knob adds a random amount of pitch variance to each note as it is played. This can create a richer and more natural sound, and can somewhat emulate the imprecision and drift of early analog components. Rotating this knob to the right will increase the breadth of the pitch variance range.

**NOTE:** The Front Panel shows a value range of 0 to 10. Opening the Polyphony MORE Page will open a graphic image in the left pane of the Center Console display, showing this value being changed from 0% to 100%.



## POLYPHONY MORE PAGE

Pressing the triangular **MORE** button in the upper right corner of the POLYPHONY module will reveal a second level of parameters than can be accessed and modified using the interactive portion of the Center Console. The left pane shows the width of the Detune Amount, as determined by the **DETUNE** knob on the Front Panel. The right pane shows the current values of the Front Panel parameters for this module. Tweaking these panel controls will update their values here. The additional MORE parameters are displayed in the bottom portion of the screen.

**NOTE:** Pressing the (now) illuminated **MORE** button will exit the MORE page and recall the HOME screen.

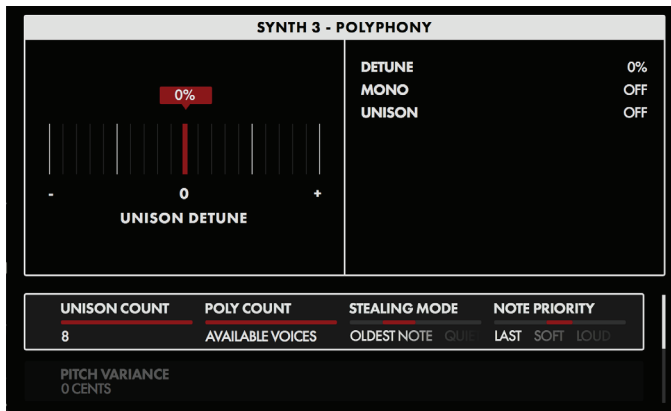

These onscreen parameters are accessed using the Master Encoder and the four Soft Knobs below the screen.

### CHANGING THE VALUE

Simply rotate the Soft Knob below the parameter name to change its value. In some cases, the Soft Knob simply turns a function on or off. In other cases, it may choose from a list of values or settings, and in other cases, the Soft Knob is dialing in a value – either absolute or a percentage

### SELECTING A ROW

Rotate the Master Encoder to the right to highlight the next row of parameters. Rotating the Master Encoder to the left will select a previous row. Again, rotate the Soft Knob below the parameter to change its value.

### UNISON COUNT (MINIMUM = 2; MAXIMUM = POLY COUNT VALUE)

The number of voices allocated here will determine the depth and fatness of the Unison effect. The minimum number of voices is = 2, the maximum limit is the number of voices set by the POLY COUNT parameter (see below). When the **MONO** mode is selected on the Front Panel, all of the voices specified here will be stacked in Unison on that one note. However, when the **MONO** mode is set to Off, Moog One will continue to allocate Unison voice-stacking in the POLY mode. On a 16-voice Moog One, you could set the UNISON COUNT to 4, and up to four notes could be played with a four-voice Unison stack. Conversely, if both the UNISON COUNT and the POLY COUNT are set to 16, then the first note played would be allocated the full 16 voices; when a second note is added, 8 voices would be allocated to each, etc.

### POLY COUNT (MINIMUM = 2; MAXIMUM = AVAILABLE HARDWARE VOICES)

Here you can specify the maximum number of voices allocated to the active Synth while in the POLY mode (**MONO** button is Off). When performing using a Preset that may play multiple Synths simultaneously (layers, splits, etc.), limiting the POLY COUNT can improve how voices are effectively shared and allocated among the Synths.

## **POLYPHONY MORE PAGE** *(Continued)*

### **VOICE STEALING MODE** *(NO STEALING, OLDEST NOTE, QUIETEST NOTE, NEWEST NOTE)*

This parameter specifies how voices will be sacrificed and reallocated when the active Synth reaches its polyphony limit.

#### **NO STEALING**

This is effectively the Off position for this parameter. No new notes are played until voices become available.

#### **OLDEST NOTE**

Here, the note that has been sounding the longest is the first to be stolen when a new note is played. This mode is excellent for playing fast and intricate passages, but beware when playing a sustained chord that use may a root (or pedal-point) note under a series of changes, as it may drop unexpectedly.

#### **QUIETEST NOTE**

This is the “weakest link” mode. Here, the voice that is contributing the least (hence quietest) in the overall sound will be dropped so that a new note may be played.

#### **NEWEST NOTE**

While dropping the newest note may seem counterintuitive, this is actually a powerful mode for creating mono-synth style figures and solos over a polyphonic base, by continually reallocating the same voice to the next note played (when the polyphony limit has been reached).

### **MONOPHONIC NOTE PRIORITY** *(LOW, HIGH, LAST)*

This is sort of the monophonic equivalent of polyphonic voice stealing; NOTE PRIORITY determines which note will sound when multiple notes are pressed while performing in the MONO mode.

### **PITCH VARIANCE** *(0 CENTS to 50 CENTS)*

To emulate some of the imprecision and drift of early analog components, this parameter adds a random amount of variation to the pitch of each new note as it is played – within the limits set by this value. This can create a richer and a more “classic” analog sound. Rotating this knob to the right will increase the breadth of the PITCH VARIANCE range.

# MODULATION

In basic terms, modulation allows a control signal from one module to influence the value of a parameter in another module. A modulation path needs both a source and a destination. In a truly modular world, each modulation pathway is created by connecting a separate patch cord from the modulation source to the destination – often side stepping along the way to invert the value, to add a controller, or to use a multiple (Mult.) jack to carry the signal to multiple destinations. Cyclic modulation sources (such as LFOs) generate excellent control signals for adding vibrato and tremolo. Envelopes can deliver multi-segment control signals that evolve to shape a sound over time. This is the crux of modular synthesis. Moog One can create, catalog, save, and maintain countless modulation pathways, adding greatly to the precision, depth, and animation of the final sound.

Moog One employs three basic means for addressing modulation: Hard-Wired; Quick Assign; and the unparalleled Modulation Matrix.

## HARD-WIRED MODULATION

Some modulation pathways are so common and well established in the world of synthesis and sound design that Moog One offers their immediate control using dedicated hardware. These hard-wired modulation controls appear along the bottom portion of the individual Oscillator modules, and in the lower portion of the Filter modules. These shortcuts should in no way be seen as limiting to the user; any of these modulation sources and destinations can be connected in new and different ways using the expansive Modulation Matrix.

## HARD-WIRED OSCILLATOR COMMON MODULATION PARAMETERS

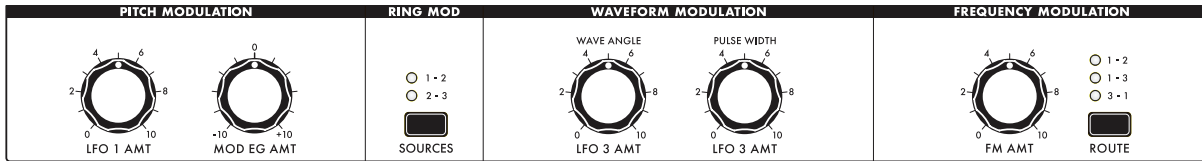

Here, the Pitch Modulation and Waveform Modulation parameters are applied to all Oscillators equally. Selecting the Ring Modulation sources and choosing a Frequency Modulation routing are also performed using the controls found in this section.

## HARD-WIRED FILTER COMMON MODULATION PARAMETERS

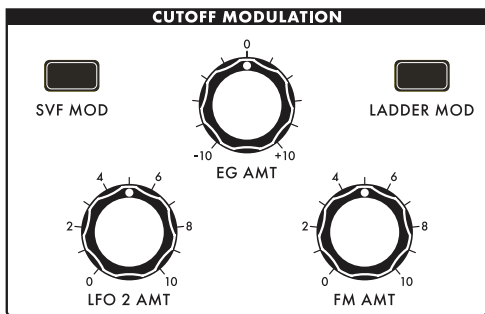

These knobs control the amount of Cutoff Frequency modulation being applied by these sources. The amounts can be the same for both filters, or they can be adjusted separately. When the **SVF MOD** button is lit, these knobs can be used to tweak the modulation amounts being applied to the State Variable Filter. When the **LADDER MOD** button is lit, these knobs can be used to tweak the modulation amounts being applied to the Ladder filter. When both the **SVF MOD** button and the **LADDER MOD** button, tweaking these knobs will affect both filters equally. The specific values of these parameters can be

seen in the right pane of the Filter MORE page.

**NOTE:** Regardless of which buttons are lit - **SVF MOD** and/or **LADDER MOD** - or unlit, the modulation amounts for each filter, specified in the Filter MORE page, are being applied. The buttons work only to select which filter(s) will be affected by further tweaking of these knobs.

The functions of these modulation controls are discussed in the Oscillator Common Parameters and Filter Common Parameters sections of this manual.

## MODULATION *(Continued)*

### QUICK ASSIGN MODULATION

Specific modulation sources and modulation expression controllers can be assigned on the fly.

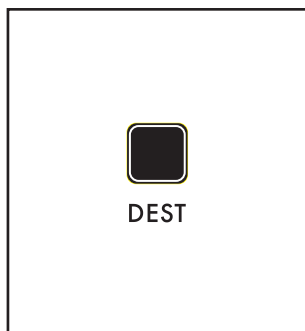

#### DEST

Pressing the **DEST** (Destination) button found in the lower right corner of any Low Frequency Oscillator (LFOs 1, 2, 3, or 4) or in the lower right corner of any EG (Filter Envelope, Amplitude Envelope, Modulation Envelope) will instantly create a new Modulation pathway using that LFO or EG as the source.

This same method of modulation routing is available by pressing one of the seven **EXPRESSION ASSIGN** buttons at the bottom edge of the Center Console, which similarly assign a controller to a specific modulation destination.

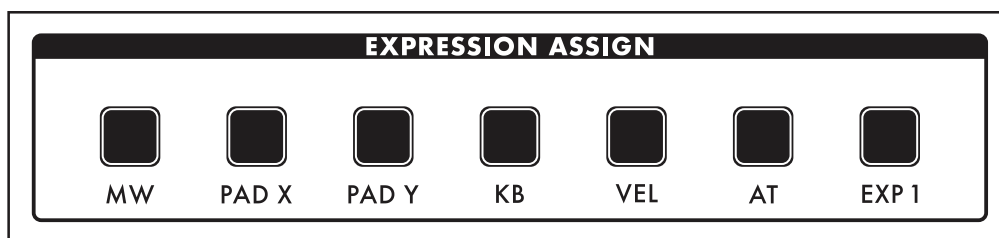

Once a **DEST** or an **EXPRESSION ASSIGN** button has been pressed, the Quick Assign modulation screen will open in the Center Console. In this example, LFO 1 was the chosen as the modulation source.

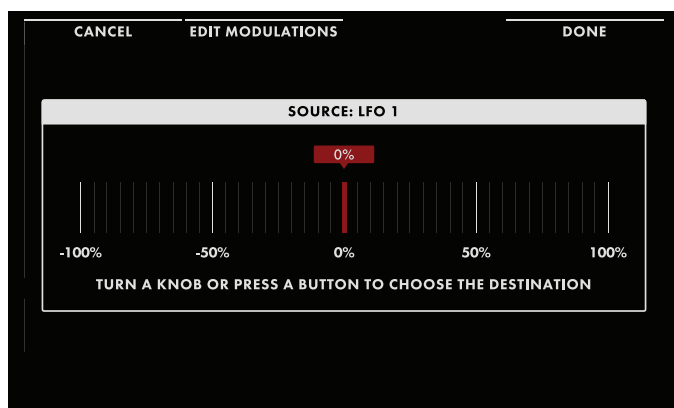

The destination will be assigned automatically to the first hardware parameter that is touched or operated. In this example, Oscillator 2 Frequency has been chosen as the modulation destination. As the destination parameter knob is turned, the value in the display will change to show the depth of the modulation effect being applied.

**NOTE:** This rotating of the knob to set the depth of the modulation effect does not alter the saved value of the parameter.

**TIP:** If the first parameter operated was not the intended destination, you can press the **DEST** or **EXPRESSION ASSIGN** button again to return to the "CHOOSE THE DESTINATION" screen.

## MODULATION *(Continued)*

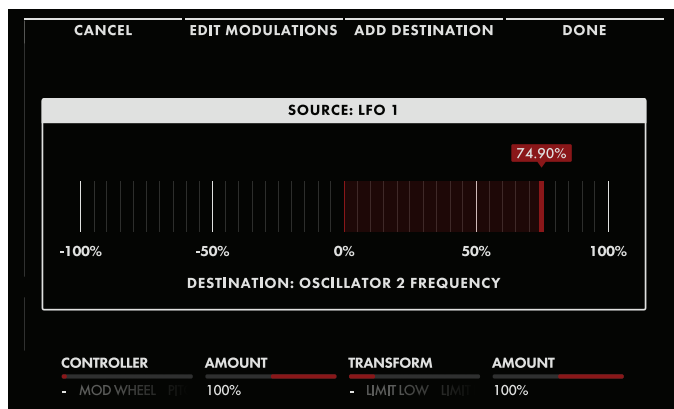

Four Soft Buttons are labelled at the top of the screen.

### **CANCEL**

Pressing the CANCEL Soft Button will exit the Quick Assign window without saving the new modulation path.



### **EDIT MODULATIONS**

Pressing the EDIT MODULATIONS Soft Button opens up a special case of the Modulation Matrix screen that is filtered by source, showing only the modulation paths that have the same source as this newly created path; again in this case, LFO 1. Navigating inside the Modulation Matrix is covered extensively in the next section.

### **ADD DESTINATION**

Pressing the ADD DESTINATION Soft Button saves the current modulation (same as the DONE button) and returns to the initial Quick Assign screen, where an additional destination for the same modulation source may be chosen simply by touching another hardware knob or button.

### **DONE**

Pressing the DONE Soft Button will exit the Quick Assign window while saving the new modulation path.

## MODULATION (Continued)

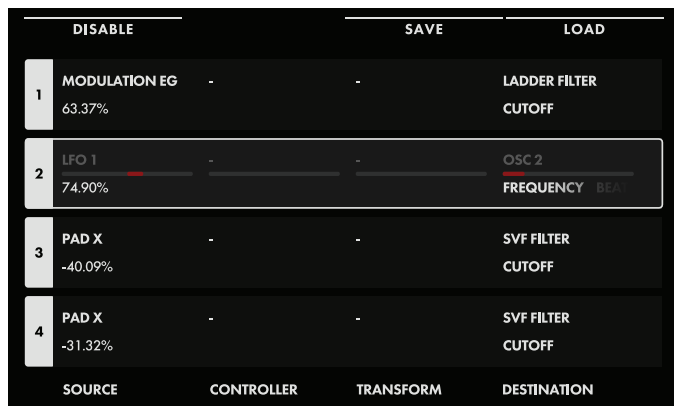

### MODULATION MATRIX

The Modulation Matrix is the nexus for all modulation paths assigned to the active Synth. This includes assignments made here, and those made using the Quick Assign method; they all are part of one Modulation Matrix. Pressing the **MOD** button in the Center Console opens the Modulation Matrix screen.

Each modulation path is placed in a numbered slot for ease of access and editing. Rotate the Master Encoder to select a modulation slot. When a

modulation path has been established, the defining parameters of the modulation path will appear in the slot. If no modulation path has been established in the selected slot, the + + + + indicators will show that the slot is ready to hold a new modulation path.

The parameters for the selected modulation path appear in two rows. The active row will appear in white; the other row will be grayed out. To toggle between the two rows in the selected slot, press down on the Master Encoder. Regardless of which row is active, the modulation path parameters are edited using the four Soft Knobs at the bottom of the screen, and the three Soft Buttons up top.

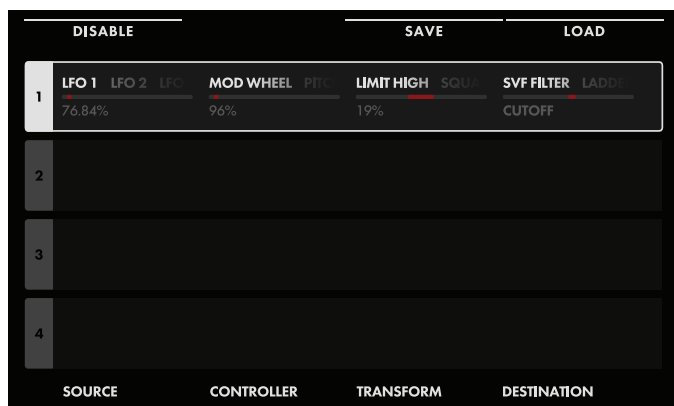

### EDITING OR CREATING A NEW MODULATION PATH

To edit an existing modulation path, select and highlight the appropriate modulation slot by rotating the Master Encoder. Use the Soft Knobs to edit an existing value. To create a new path inside the Modulation Matrix, rotate the Master Encoder to select the first available empty (unassigned) slot. Use the Soft Knobs to assign a source, destination, etc. to the new modulation path. In either case, press down on the Master Encoder to toggle between top row and bottom row parameters.

**TIP:** As an aid to programming, the far left Soft Button acts as a toggle, allowing the selected modulation path to be quickly disabled/enabled, without the need to permanently delete the path.

### SOURCE

**TOP ROW:** Source Parameter Name

**BOTTOM ROW:** Source Parameter Value: -300% to 0 to +300%

The first step is to select a modulation source. Be sure the top row is selected and use the SOURCE Soft Knob to choose the modulation source. Next, press the Master Encoder to access the Bottom Row parameters and specify a value to indicate the strength of the modulating signal. When the value is set to 0, the modulation strength is also zero (no effect). Positive values will produce normal modulation; negative values will produce modulation with an inverted signal.

**TECHNICAL NOTE:** Although the Source Amount appears before the Controller Amount and Transform Amount values; this value is actually applied after the control signal leaves the Controller and the Transform, but before it reaches the destination. This allows the Controller/Transform to receive the modulation signal at full strength for more accurate processing. Then the Source Amount is applied to set the level.

## MODULATION *(Continued)*

### CONTROLLER

**TOP ROW:** *Controller*

**BOTTOM ROW:** *Controller Value: -100 to 0 to +100%*

The modulation source can be applied directly to the modulation destination, or the amount of modulation can be articulated using an assignable controller such as Aftertouch. The amount of modulation can also be attenuated by using another mod source as a controller, such as an LFO or EG. Use the Controller Soft Knob to select a controller, or simply select NONE. Controller Amount determines how strongly the Controller affects the amount of modulation. When the Controller Amount is set to 0, the value of the selected controller has no effect on the modulation strength. If the Controller Amount is positive, then high Controller values create stronger modulation effects while low Controller values reduce the amount of modulation. If the Controller Amount is negative, then the effect of the Controller is reversed (a low Controller value allows more modulation to come through, while increasing the Controller value attenuates the strength of modulation). If no Source is selected but a Controller is assigned, then the Controller behaves like a Source and the Controller Amount behaves as described above for the Source Amount.

### TRANSFORM

Placing a Transform in the modulation path offers a number of ways to manipulate the value of the modulation signal as it travels from the source to the destination. The Transform is selected using the top parameter row; the value is entered using the bottom row parameters.

#### **NONE**

This is the default setting; no transform has been applied to the modulation path.

#### **LIMIT LOW** *(0 to 100%)*

This Transform artificially sets a lower limit on the value of the control signal. Values above this low limit are played normally. Values below the low limit will be output using the value of the low limit setting.

#### **LIMIT HIGH** *(0 to 100%)*

This Transform artificially sets an upper limit on the value of the control signal. Values below this high limit are played normally. Values above the high limit will be output using the value of the high limit setting.

#### **SQUARED** *(FIXED)*

The value of the Transform output is equal to the input value multiplied by itself, or squared.

#### **CUBED** *(FIXED)*

The value of the Transform output is equal to the input value multiplied by itself twice, or cubed.

### DESTINATION

**TOP ROW:** *Destination Module Name*

**BOTTOM ROW:** *Destination Parameter Name*

The Destination specifies the parameter that will ultimately be controlled by this modulation path. The list of modulation destinations is extensive. To make it easier to select a destination quickly, the top row parameter will select the Moog One Module, the bottom row parameter will choose the destination parameter from within that module.

## MODULATION *(Continued)*

### DELETING A MODULATION PATH

To delete an existing modulation path, select the appropriate modulation slot by rotating the Master Encoder and press the **DELETE** button in Center Console. The modulation path will be deleted, and the existing modulation paths residing in higher numbered slots numbers will move to fill the gap. So if the modulation path in slot 4 is deleted, the path that was in slot 5 will become the new number 4, etc.

### FILTERING THE MODULATION LIST BY SOURCE OR DESTINATION

As the number of modulation paths within a specific Modulation Matrix expands, filtering the list by modulation source or modulation destination can make it easier to find and edit a particular modulation path by displaying an abridged list. When the Modulation Matrix is opened in this manner, the second Soft Button from the left (CLEAR SRC FILTER / CLEAR DEST FILTER) can be pressed to clear any filtering of the Modulation Matrix list.

***TIP:** Notice that when modulation paths appear in the filtered list, they retain their existing slot numbers, which can also make it easy to find and reference them in the future.*

	DISABLE ALL	CLEAR SRC FILTER	SAVE	LOAD
1	LFO 1 76.84%	MOD WHEEL 96%	LIMIT HIGH 19%	SVF FILTER CUTOFF
2	LFO 1 -32.73%	-	-	EG 3 ATTACK
3	LFO 1 64.93%	-	-	SVF FILTER RESONANCE
5				
	SOURCE	CONTROLLER	TRANSFORM	DESTINATION

### FILTERING BY SOURCE

Holding the **SHIFT** button while pressing any one of the **DEST** buttons on the Front Panel (LFOs, EGs) will open the Modulation Matrix, but showing only the modulation paths using that module as a source. In the example above, the **SHIFT** button was held while the LFO 1 **DEST** button was selected, and only the modulation paths using LFO 1 as a modulation source are shown. Pressing the CLEAR SRC FILTER Soft Button will clear the source filter, and all modulation paths in the Modulation Matrix will be displayed.

### FILTERING BY DESTINATION

Holding the **SHIFT** button while pressing any one of the **MORE** buttons on the Front Panel (OSCS, FILTERS, etc.) will open the Modulation Matrix, but showing only the modulation paths whose destination is included in the selected module. Pressing the CLEAR DEST FILTER Soft Button will clear the destination filter, and all modulation paths in the Modulation Matrix will be displayed.



## MODULATION *(Continued)*

### SAVING AND LOADING A MODULATION MATRIX

Once a complete Modulation Matrix has been created, it can be saved for future use. When a Modulation Matrix is recalled, it can be used as is, or edited and re-saved under a new name, without having to rebuild the entire Modulation Matrix from scratch. This way, if there are particular routings that you are fond of using, these settings can be kept readily at hand as a saved Modulation Matrix preset.

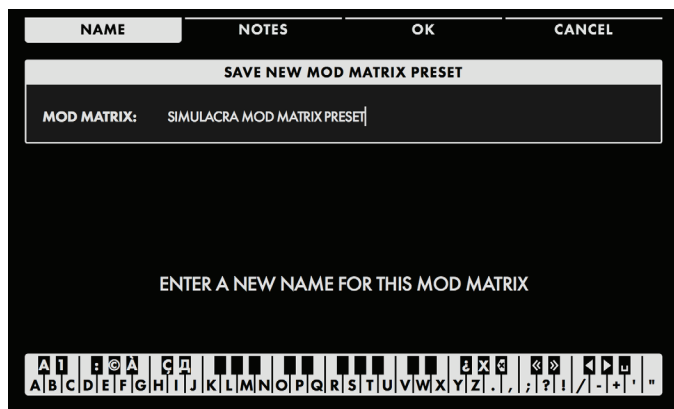

### SAVING A MODULATION MATRIX

Pressing the SAVE Soft Button will open the Save Modulation Matrix Preset screen. The four Soft Buttons across the top are NAME, NOTES, OK, and CANCEL.

When the SAVE screen opens, the NAME Soft Button will already be selected, and the screen prompt will ask you to name the current Modulation Matrix.

Once you have entered a name for the Modulation Matrix, you can also enter any optional performance notes using the same method. These notes can be quick reminders or application cues, such as “Uses staggered and sync’d LFOs” or “this is the one Gerry created during the studio session” etc. Press the NOTES Soft Button and follow the screen prompts. After naming the Modulation Matrix and adding any notes, press the OK Soft Button to save the Modulation Matrix, or press the CANCEL Soft Button to exit the Modulation Matrix SAVE screen without saving.

### ENTERING TEXT

Moog One allows you to enter names and text directly from the keyboard. The white keys (naturals) enter the characters; certain black keys (accidentals) have specific functions.

- Keys C#1 - D#2 select the character set.
- Key F#4 removes the current name and randomly generates a new name.
- Key G#4 clears all the characters in the screen.
- Key A#4 deletes the character to the left of the cursor.
- Keys C#5 and D#5, respectively, change the character immediately preceding the cursor to the previous or next symbol in the current character set, changing an M to an L or an N, for example with a single key press.
- Keys F#5 and G#5 move the cursor left or right, respectively.
- Key A#5 adds a space.

**NOTE:** The note numbers given above relate to the onscreen keyboard, and do not reflect the key’s actual MIDI Note number, etc.

**TIP:** You can also enter text directly, using a standard USB keyboard connected to the Moog One **USB HOST** port.

## MODULATION *(Continued)*

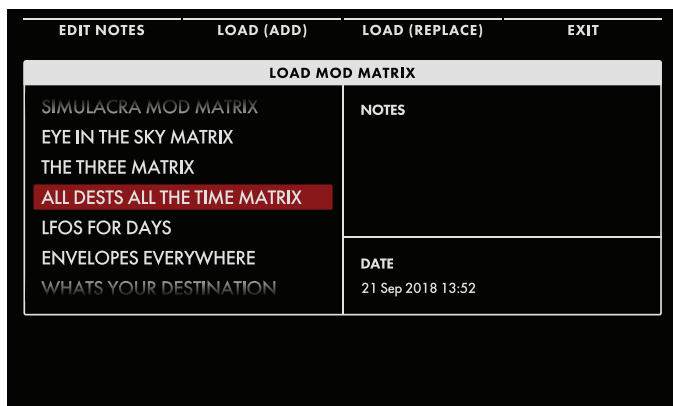

### LOADING A MODULATION MATRIX

Pressing the LOAD Soft Button will open the LOAD Modulation Matrix Browser screen. A list of saved Modulation Matrix presets is shown in the left pane. The upper right pane shows any performance notes that were saved with the Modulation Matrix preset, and the lower right pane provides a timestamp of the saved data. The four Soft Buttons across the top are EDIT NOTES, LOAD (ADD), LOAD (REPLACE), and EXIT.

### EDIT NOTES

Rotate the Master Encoder to choose a Modulation Matrix preset from the list. Pressing the EDIT NOTES Soft Button will open the text entry screen, where using the keyboard as the entry device, you can change, edit, or replace the performance notes saved with this Modulation Matrix preset. In this case, the Modulation Matrix is never loaded, but the notes text (metadata) is updated. When you are done editing the notes, press the OK Soft Button to save the changes, or the CANCEL Soft Button to exit without saving.

### LOAD (ADD)

Rotate the Master Encoder to choose a Modulation Matrix preset from the list. Pressing the LOAD (ADD) Soft Button will load the selected Modulation Matrix in to the active Synth, adding the Modulation paths to the existing Modulation Matrix.

### LOAD (REPLACE)

Rotate the Master Encoder to choose a Modulation Matrix preset from the list. Pressing the LOAD (REPLACE) Soft Button will load the selected Modulation Matrix in to the active Synth, replacing any existing modulation paths.

### EXIT

Pressing the EXIT Soft Button will close the Load Matrix Modulation screen and return to the previous screen.

## MODULATION *(Continued)*

### MODULATION MATRIX APPENDICES

Here you can find the complete list of all available Sources, Controllers, Transforms, and Destinations that can be used to create a path in the Modulation Matrix.

LFO 2	PITCH WHEEL	LIMIT HIGH
LFO 3	PAD X	SQUARED
LFO 4	PAD Y	CUBED
FILTER EG	PAD PRESSURE	
AMPLIFIER EG	PAD GATE	
MODULATION EG	VELOCITY	
NOISE EG	AFTERTOUCH	
MOD WHEEL	KEY PITCH	
PITCH WHEEL	KB GATE	
PAD X	SUSTAIN	
PAD Y	EXP 1	
PAD PRESSURE	EXP 2	
PAD GATE	CV IN 1	
VELOCITY	CV IN 2	
AFTERTOUCH	FILTER EG	
KEY PITCH	AMPLIFIER EG	
KB GATE	MODULATION EG	
SUSTAIN	NOISE EG	
EXP 1	LFO 1	
EXP 2	LFO 2	
CV IN 1	LFO 3	
CV IN 2	LFO 4	
RANDOM	RANDOM	
RANDOM BIPOLAR	RANDOM BIPOLAR	
CONSTANT	CONSTANT	

## MODULATION *(Continued)*

### DESTINATIONS

PITCH LFO 1 MOD	COLOR MIX	DELAY
PITCH EG MOD	ATTACK	ATTACK
TRIANGLE LFO 3 MOD	SUSTAIN	HOLD
PULSE LFO 3 MOD	RELEASE	DECAY
FM MOD	<b>MIXER</b>	SUSTAIN
PITCH OFFSET	OSC 1 LEVEL	RELEASE
<b>OSCILLATOR 1</b>	OSC 2 LEVEL	TIME SCALE
FREQUENCY	OSC 3 LEVEL	<b>EG 2</b>
BEAT	RMOD LEVEL	DELAY
SAW	NOISE LEVEL	ATTACK
TRIANGLE	EXT LEVEL	HOLD
PULSE	<b>VCA</b>	DECAY
MIX	LEVEL	SUSTAIN
<b>OSCILLATOR 2</b>	PAN	RELEASE
FREQUENCY	<b>FILTERS</b>	TIME SCALE
BEAT	SVF/LADDER MIX	<b>EG 3</b>
SAW	<b>SVF FILTER</b>	DELAY
TRIANGLE	CUTOFF	ATTACK
PULSE	RESONANCE	HOLD
MIX	SPACING	DECAY
<b>OSCILLATOR 3</b>	EG AMOUNT	SUSTAIN
FREQUENCY	LFO 2 AMOUNT	RELEASE
BEAT	FM AMOUNT	TIME SCALE
SAW	<b>LADDER FILTER</b>	
TRIANGLE	CUTOFF	
PULSE	RESONANCE	
MIX	EG AMOUNT	
	LFO 2 AMOUNT	
	FM AMOUNT	



## ARPEGGIATOR

At its most basic level, an arpeggiator scans the notes being held down on the keyboard and plays them one at a time in a cyclic and rhythmic fashion. This description doesn't even begin to come close to describing the Moog One Arpeggiator. Octave Order, Pendulum Mode, and Random patterns allow this Arpeggiator to become an extra set of hands, create an electronic counterpoint, generate cascades of notes, and to form the solid base of a rhythmic groove.

The Arpeggiator exists at the Synth level, and all Arpeggiator parameters are saved with their respective Timbre as part of the Preset. In this way, a single Preset can have up to three active Arpeggiators (one per Synth) at any time, each playing a different pattern, using a different sound, and in a different zone on the keyboard. The Arpeggiators – along with the Sequencers, LFOs and EGs – can be sync'd to the tempo of the Master Clock to create a unified rhythmic performance. Unlike a sequencer, which is playing patterns of specific notes stored in memory, the Arpeggiator is generating data in real time, based on the notes being played; it is a bit more interactive, and is always musically related to the performance.

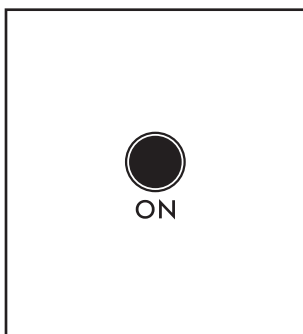

### **ON** (ON/LIT, OFF/UNLIT)

This button turns the Arpeggiator of the active Synth On and Off.

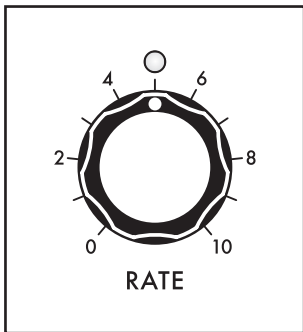

### **RATE** (0 to 10)

The **RATE** knob sets the speed of the Arpeggiator. The actual tempo value ranges from 10 BPM to 280 BPM. The Arpeggiator Rate can run at an independent speed, or it can be synchronized to the Master Clock using the parameters accessed in the Arpeggiator MORE page. The **RATE** knob LED will flash at the current setting.

**NOTE:** If the Arpeggiator is sync'd to the Master Clock, then rotating the **RATE** knob will select quantized clock divisions of the Master Clock. All of the SYNC parameters are available in the Arpeggiator MORE page.

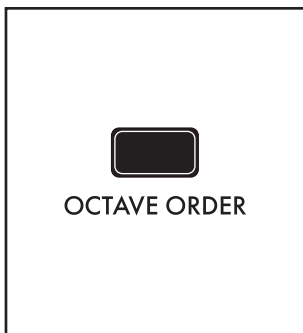

### **OCTAVE ORDER** (ON/LIT, OFF/UNLIT)

Traditionally, when an arpeggiator is set to play over a multi-octave range, all of the notes are played in the current octave, and then the pattern is repeated an octave higher, etc. When the **OCTAVE ORDER** switch is On, the Arpeggiator pattern will play the first note in the pattern in each octave, then the second note of the pattern repeated in each octave, etc.

**EXAMPLE:** The notes in the pattern are a C Major triad (C, E, G) and the **OCTAVE** range is set to three. With **OCTAVE ORDER** set to Off, the pattern generated would be C1-E1-G1, C2-E2-G2, C3-E3-G3, etc. With **OCTAVE ORDER** set to On, the pattern generated would be C1-C2-C3, E1-E2-E3, G1-G2-G3, etc.

## ARPEGGIATOR *(Continued)*

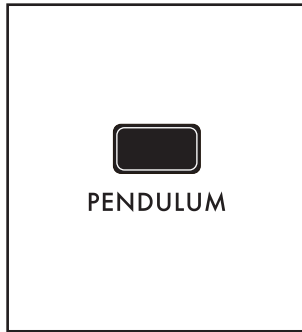

### **PENDULUM** (ON/LIT, OFF/UNLIT)

Pendulum changes the way the pattern is repeated. When the **PENDULUM** button is set to On, once the entire arpeggiator pattern has played through, the Pendulum function will play the entire arpeggiator pattern again in the reverse order, and then the pattern will play again normally, etc. This back and forth motion is similar to that of a pendulum. When the **PENDULUM** button is Off, the pattern plays in its usual order.

**TIP:** While certain combinations of **DIRECTION** and **PATTERN** already exhibit this type of behavior, adding **PENDULUM** motion to **RANDOM** and **ORDER** modes can be particularly effective.

**NOTE:** The **PENDULUM MODE** parameter in the Arpeggiator **MORE** page affects the turnaround notes of the pattern.

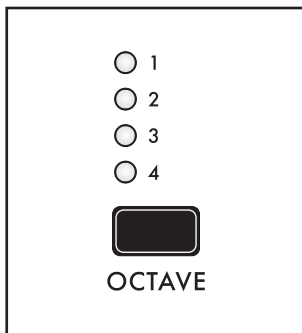

### **OCTAVE** (1, 2, 3, 4)

Increasing the Octave value will cause the arpeggiator pattern to play through once in the original octave, and then to repeat in successive octaves pitched higher or lower than the original. Press the **OCTAVE** button to cycle through the list of values; the corresponding LED will light. The minimum value is = 1, which plays the pattern in its original octave; the maximum value is = 4, which plays the pattern in its original octave, then an octave higher/lower, then two octaves higher/lower, and then three octaves higher/lower. The choice between higher and lower is made using the **DIRECTION** button.

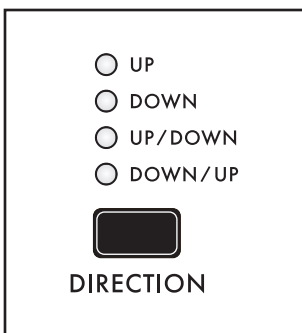

### **DIRECTION** (UP, DOWN, UP/DOWN, DOWN/UP)

When multiple octaves are selected using the **OCTAVE** button, this Direction parameter specifies whether these additional octaves are higher (**UP**) or lower (**DOWN**) in pitch than the original octave. Press the **DIRECTION** button to cycle through the list of values; the corresponding LED will light. When **UP/DOWN** is selected, the pattern first repeats in octaves pitched higher than the original, and then reverses direction to play through the selected octaves to reach the original pitch. When **DOWN/UP** is selected, the pattern first repeats in octaves pitched lower than the original, and then reverses direction to play through the selected octaves to reach the original pitch.

## ARPEGGIATOR *(Continued)*

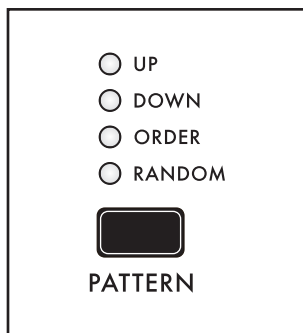

### **PATTERN** (*UP, DOWN, ORDER, RANDOM*)

It is this parameter that specifies the pattern in which the arpeggiated notes are played.

#### **UP**

Notes are arpeggiated from the lowest pitch to the highest pitch.

#### **DOWN**

Notes are arpeggiated from the highest pitch to the lowest pitch.

#### **ORDER**

Notes are arpeggiated based on the order in which they were played.

***TIP:** In this mode, a held key can be released and then immediately played again to change its order in the pattern, creating a new feel and groove while performing.*

### **RANDOM**

Notes are arpeggiated in a random order.

***NOTE:** The **RANDOM MODE** parameter found in the Arpeggiator **MORE** page offers a choice between both repeating and non-repeating Random patterns.*

## **ARPEGGIATOR MORE PAGE**

Pressing the associated triangular **MORE** button in the upper right corner of the Arpeggiator module will reveal a second level of parameters that can be accessed and modified using the interactive portion of the Center Console. These additional parameters are displayed in the bottom portion of the screen. The right pane shows the current value of the Front Panel hardware parameters for this module. Tweaking these panel controls will update their values here.

***NOTE:** Pressing the (now) illuminated **MORE** button will exit the **MORE** page and recall the **HOME** screen.*

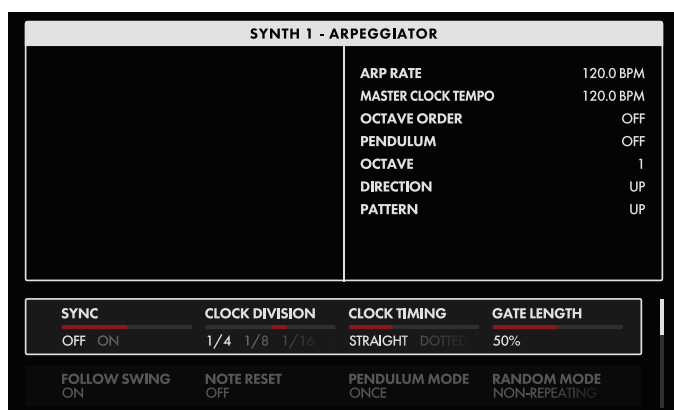

The onscreen **MORE** page parameters are edited using the four Soft Knobs below the screen.

### **CHANGING THE VALUE**

Rotate the Soft Knob below the parameter name to change its value. In some cases, the Soft Knob simply turns a function on or off. In other cases, it may choose from a list of values or settings, and in other cases, the Soft Knob is dialing in a value – either absolute or a percentage.

### **SELECTING A ROW**

The scroll bar at the right edge indicates the current row. Rotate the Master Encoder to the right to highlight the next row of parameters. Rotating the Master Encoder to the left will select a previous row. Again, rotate the Soft Knob below the parameter to change its value.



## **ARPEGGIATOR** *(Continued)*

### **SYNC** *(OFF, ON)*

When SYNC is Off, the Arpeggiator is free to run at its own speed and clock rate. When SYNC is On, the Arpeggiator and Master Clock are synchronized, and the Master Clock determines the Arpeggiator tempo.

**NOTE:** When SYNC is selected here, rotating the Arpeggiator **RATE** knob on the Front Panel will select quantized clock divisions (see below) of the Master Clock.

### **CLOCK DIVISION** *(4, 2, 1, 1/2, 1/4, 1/8, 1/16, 1/32)*

When sync'd, the Master Clock provides a tempo base; divisions of that Master Clock are used to set the Arpeggiator speed. Changing the CLOCK DIVISION parameter specifies the timing in terms of quarter-note beats.

### **CLOCK TIMING** *(STRAIGHT, DOTTED, TRIPLET)*

When sync'd, Clock Timing provides a further modification of the step duration, allowing for a wider selection of note timings relative to the Master Clock tempo.

#### **STRAIGHT**

The timing of each note is played as specified by the Clock Division.

#### **DOTTED**

The timing of each note is modified to play as a dotted note, or at 1.5 x the value specified by the CLOCK DIVISION parameter.

#### **TRIPLET**

The timing of each note is modified to play as if it were one note in a triplet, or at 2/3rds of the value specified by the CLOCK DIVISION parameter.

### **GATE LENGTH** *(1% to 100%)*

Adjusting the GATE LENGTH parameter changes the duration of each arpeggiated note in the pattern. Lower values will be more percussive and abrupt, higher values will be more flowing and legato.

### **FOLLOW SWING** *(OFF, ON)*

The Master Clock includes parameters related to adding swing to the beat. When sync'd to the Master Clock, the Arpeggiator can either follow this swing information, or ignore it and play strictly to the BPM setting.

### **NOTE RESET** *(OFF, ON)*

This parameter specifies how the timing of the Arpeggiator will behave when a new note is played on the keyboard. When the NOTE RESET parameter is On, the Arpeggiator begins instantly, resetting the downbeat timing of the current Clock Division to match the note as it is played. When the NOTE RESET parameter is Off, the Arpeggiator will wait for the start of the next specified Clock Division before the pattern begins.

### **PENDULUM MODE** *(ONCE, TWICE)*

This PENDULUM MODE parameter is different that the Pendulum function of the Front Panel. Here, the parameter specifies if the notes at the extreme ends of the Arpeggiator pattern are played once before reversing direction, or twice – once for the last note on the way up, and again as the first note on the way down. This allows the Moog One arpeggiator to accurately mimic the behavior of different Arpeggiators from different keyboards that have been popular over the years.

### **RANDOM MODE** *(NON-REPEATING, REPEATING)*

This parameter specifies how the notes in a RANDOM pattern will be played. Choosing NON-REPEATING prevents the same note from being played twice (or more times) in succession, so the pattern is slightly less than random. By choosing REPEATING, no constraints are imposed on the randomness of the pattern, and the same note may be played twice (or more) in a row.

## SEQUENCER

Although their function is pretty straight forward, sequencers are fairly remarkable. As the name implies, they are responsible for memorizing, saving, and replaying a sequence of notes – either in a continuous loop, or as a one-time event. The sequencer is one of the founding elements of electronic music production; playing a series of pitches with clockwork precision, leaving the performer free to continually modify the timbre and tweak countless parameters. In addition to the note value(s) stored for each sequencer step, modulation routings and amounts can also be stored with each step.

In the Moog One, each Synth is equipped with a polyphonic step-sequencer. This allows each Preset to access up to three sequencers simultaneously – one for each Synth. Each sequence can be up to 64 steps long, arranged as pages of 16 steps. Sequences can be easily recorded and edited, and they can be transposed as they play back. The Sequencer can be sync'd to the Master Clock tempo – along with the LFOs, EGs, and the Arpeggiator – to create a forceful rhythmic performance. Each sequence can be saved as an individual entity, or as part of the active Synth/Preset.

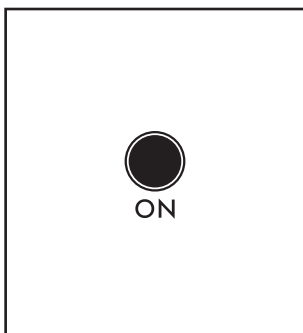

### **ON** (ON/LIT, OFF/UNLIT)

This **ON** button turns the Sequencer of the active Synth On and Off. Turning the Sequencer On will not begin the playback of an existing sequence or the recording of a new one. Instead, the **ON** button controls whether the Sequencer outputs notes to the Synth or not.

### **RATE** (0 to 10)

The **RATE** knob sets the speed of the Sequencer. The actual tempo value ranges from 10 BPM to 280 BPM. The Sequencer Rate can run at an independent speed, or it can be synchronized to the Master Clock using the parameters accessed in the Sequencer MORE page. The **RATE** knob LED will flash at the current tempo setting.

**NOTE:** If the Sequencer is sync'd to the Master Clock, then rotating the **RATE** knob will select quantized clock divisions of the Master Clock. All of the SYNC parameters are available in the Sequencer MORE page.

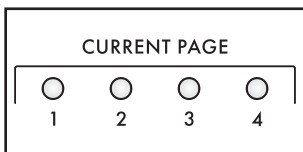

### **CURRENT PAGE / ACTIVE STEP** (LED INDICATORS)

The current Sequencer Step is indicated by the four **CURRENT PAGE** LEDs, and by the sixteen **ACTIVE STEP** LEDs.

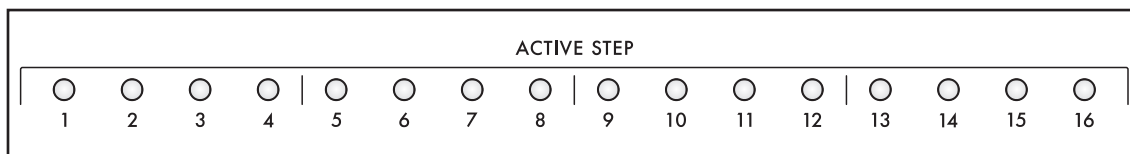

## SEQUENCER *(Continued)*

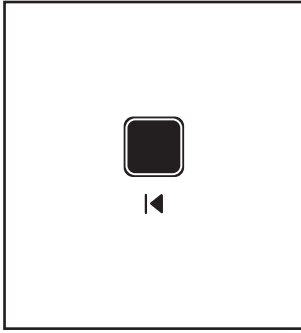

### **RETURN TO ZERO**

Pressing the **◀ RTZ** button resets the sequencer to the first step.

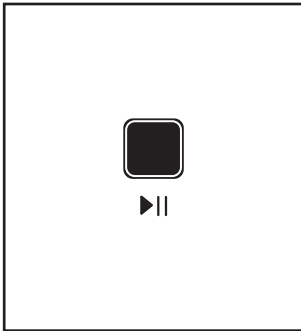

### **START/STOP** *(RUNNING/LIT, STOPPED/UNLIT)*

This **▶||** **START/STOP** button acts as a toggle, either setting the Sequencer to run, beginning at the first step, or stopping the Sequencer at the current step.

**TIP:** To start multiple sequences simultaneously - that is, one sequence from Synth 1 plus a second from Synth 3, for example - use the **PANEL FOCUS** buttons in the Center Console to select more than one Synth, and then press the **▶||** (**START/STOP**) button.

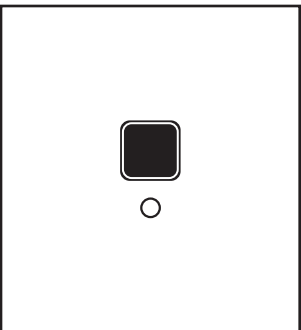

### **RECORD** *(RECORDING/LIT, NOT RECORDING/UNLIT)*

Pressing the **○ RECORD** button places the sequencer in the Record mode. Press the **○ RECORD** button a second time to exit the Record mode.

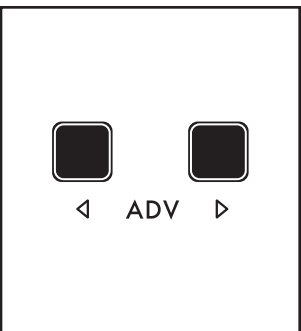

### **◀ ADV ▶** *(ADVANCE - STEP BACK, STEP FORWARD)*

These buttons are used to select the current sequence step. The current playback step is indicated by the **CURRENT PAGE** and **ACTIVE STEP** LEDs. Press the button(s) until you reach the desired step.

**TIP:** These buttons can be used to select a step in the Step Edit screen even when the sequence is running, although the Front Panel **CURRENT PAGE** and **ACTIVE STEP** LEDs will instead show the current playback step.

## SEQUENCER *(Continued)*

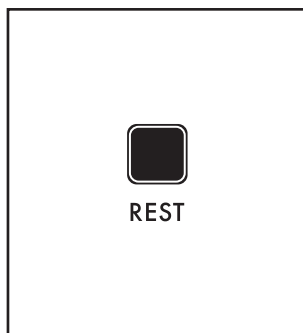

### **REST** *(ON/LIT, OFF/UNLIT)*

Pressing the **REST** button toggles a musical rest on or off for the current sequence step. If there is a rest assigned to the current step, then any notes entered on that step will not play.

**NOTE:** As the sequence plays, the **REST** button will light to indicate that the current step has been designated as a rest.

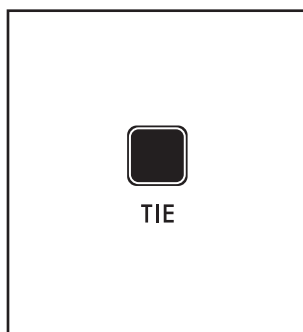

### **TIE** *(ON/LIT, OFF/UNLIT)*

Pressing the **TIE** button adds a musical tie to the current step highlighted in the Step Edit screen, connecting the notes in this step into the next, without re-triggering the envelopes at the beginning of the next step.

**NOTE:** As the sequence plays, the **TIE** button will light to indicate that the current step has been entered as tied to the next step.



### **STEP MOD** *(ON/LIT, OFF/UNLIT)*

Nearly any Synth parameter can be given a different value for the current step in the Step Edit page. But to quickly record value changes as you sweep a parameter - storing a new value at each step as the Sequencer is running - press the **STEP MOD** button to turn it On (lit), and then tweak a knob, entering a new value (offset) for each step. As long as the **STEP MOD** button is lit, you can continue to enter modulation values for multiple parameters just by rotating the corresponding knob. Finally, turn the Step Mod function Off by pressing the **STEP MOD** button a second time. Once entered, this data can be accessed and edited using the Step Edit feature.

**NOTE:** The Sequencer does not need to be placed in the Record mode to use the Step Mod feature.

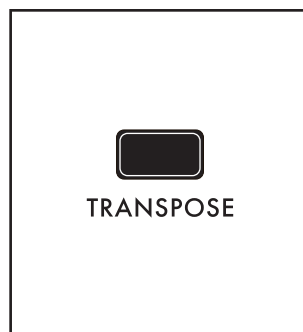

### **TRANSCOPE** *(ON/LIT, OFF/UNLIT)*

The playback of the sequence can be transposed to begin on a new key; all notes in the sequence will be transposed by that same amount. For example, if the sequence is of a C Major scale, transposing up a fourth (five keys) will produce an F Major scale. Press the **TRANSCOPE** button to turn the Transpose feature On (the button is lit), and play a new note on the keyboard to transpose the sequence; the sequence can be continually transposed by playing new notes on the keyboard. Press the **TRANSCOPE** button a second time to turn the Transpose feature Off (the button goes dark).

**NOTE:** When the **TRANSCOPE** button is lit (Transpose feature On), notes played on the keyboard will not sound the active synth. Instead, the keys are used only to enter a Transpose amount.

## SEQUENCER *(Continued)*



### **NOTE TRIG** *(ON/LIT, OFF/UNLIT)*

The Note Trigger function sets up an alternate play mode for controlling the sequence playback. When the **NOTE TRIG** button is On, the sequence will begin as soon as one (or more) keys are pressed; playback will stop when all keys have been released. This can be an excellent performance tool.

**NOTE:** *The Note Trigger play method and the Start/Stop play method are mutually exclusive; selecting one will disable the other.*

### **STEP EDIT** *(ON/LIT, OFF/UNLIT)*

Pressing the **STEP EDIT** button opens the Step Edit screen in the Center Console Display; the button will remain lit. Press the **HOME** button on the Front Panel to exit the Step Edit mode.

### **ENTERING NOTE DATA** *(STEP EDIT MODE)*

Notes entered into the Sequencer are displayed in a grid, where each column represents one step of the sequence, and each row (lane) shows the note assigned to each step. Each lane can be thought of as monophonic, so adding more lanes allows more notes to be assigned to each step. Each Sequence can be up to 64 steps in length, which is shown on the Step Edit screen, and indicated on the Front Panel as four pages of sixteen steps each. The exact number of steps is determined by the LENGTH parameter in the Sequencer MORE page.

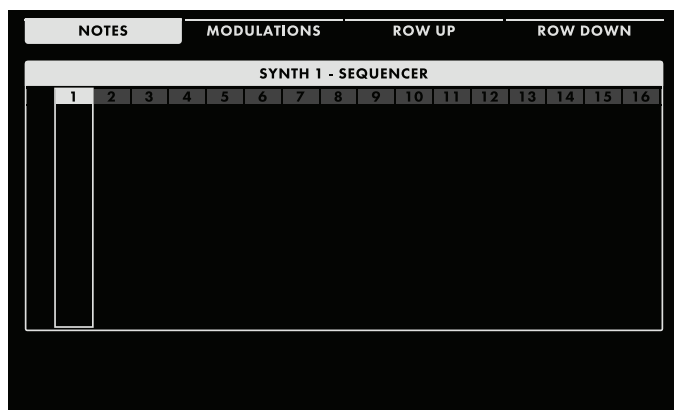

### **BEGINNING WITH AN EMPTY SEQUENCE**

The active Synth may or may not already have data stored in the Sequencer. When you press the **STEP EDIT** button on the Front Panel and see the following screen, this is a good indication that the Sequencer is empty and awaiting new data.

If there is already data present in the Sequencer, you can clear the existing data and start with a clean slate. Open the Sequencer MORE page by pressing

the triangular **MORE** button located in the upper right corner of the Sequencer module on the Front Panel. When the MORE page opens, press the CLEAR SEQUENCE Soft Button at the top of screen to initialize the Sequencer and remove all data from the active Sequence.

**NOTE:** *Pressing **SHIFT + DELETE** while the top (step number) row is selected on the STEP EDIT page will also clear the entire current sequence.*

## SEQUENCER (Continued)

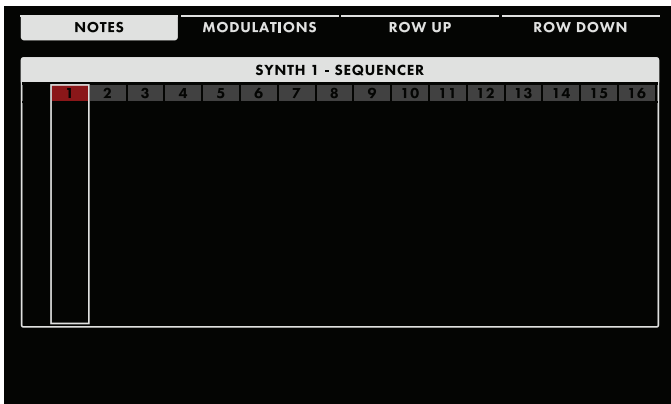

from step to step, or you can turn the Master Encoder to scroll left/right through the steps. Two soft buttons at the top of the screen allow you to move the selection Up or Down between rows (Lanes). You can also navigate up and down by turning the Master Encoder while **SHIFT** is active.

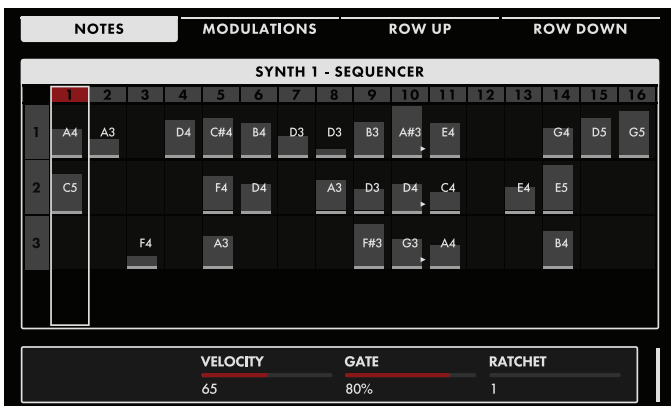

### RECORDING NOTES & ADDING LANES

If it is not already selected, press the **NOTES** Soft Button at the top of the screen. Press the **RECORD** button on the Front Panel (the button will light). Notice how the Step Indicator has turned to red, showing that the Record mode is On.

Notes may be entered using the keyboard. Once a note is played, the sequence will advance to the next step and wait for the next note, and so on. As you enter notes, You can use the **ADV** buttons to move

Each lane can only support one note per step, so adding more lanes is required to have multiple notes on each step. Pressing the **ROW DOWN** Soft button is one way to add an additional lane. You can also simply play multiple notes on a single step; Moog One will create a new lane for each additional note played. Only one lane can be active/highlighted at once, so if you create an additional lane and play only a single note for that step, it will be entered into the active lane.

**NOTE:** While it is possible to make your initial pass of entering sequence data with the Record Mode on and the Sequencer running, it is not recommended. Without a reference audio click and only the visual indicators, entering a sequenced phrase correctly will be tricky.

## SEQUENCER *(Continued)*

### TYPES OF NOTE DATA *(NOTES, TIES, RESTS, RATCHETS)*

Each sequence step can be entered as a Note, a Tie (creating a pair of Tied Notes), or a Rest. These designations – and the Ratchet Count – can be reassigned while editing.

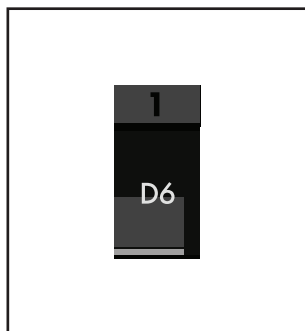

#### NOTES

Entering a Note creates a box that sits within the sequence grid for that specific step. The Note name is displayed as well. The vertical height of the box within the grid indicates the Velocity Level of the Note; the width indicates the Gate Time of the Note.

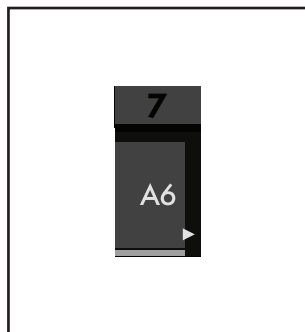

#### TIES

Any Note can be designated as a Tie, as indicated by a small arrow pointing to the following step. This instructs the sound engine (and the corresponding MIDI output) to play the following step using the same voice as in a legato fashion, without retriggering the EGs, etc.

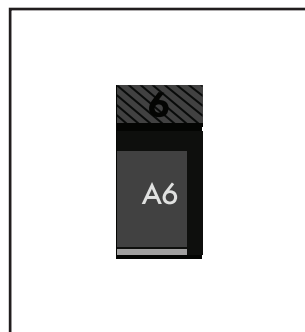

#### RESTS

Entering a Rest places a silent step into the sequence. The Step Indicator for this step will be shaded.

*TIP: A Rest step can be empty, or it may contain Note value(s). This allows the Note(s) to be restored by removing the Rest status of the step.*

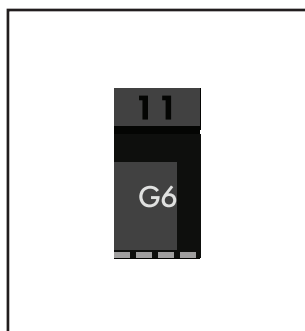

#### RATCHET STEPS

The Ratchet parameter allows the Sequencer to re-articulate a note multiple times inside of a single step; a sort of sequence stutter mode. The Ratchet Soft Knob is used to control the number of “ratchets” for the selected note.

*TIP: Often it is easier to create a step sequence by entering a Note for every step, and then going back to designate individual steps as Rests and Ties to capture the desired phrasing.*

## SEQUENCER *(Continued)*

### EDITING NOTE DATA

The Velocity, Gate Time, Ratchet Count, and Note can be edited for every sequence step. In addition, the Tie and Rest status of each note in every step can be reassigned. Note data can be edited in the Step Edit screen, whether the Record function is On or Off.

#### **NOTE** *(OFF, C0 to G10)*

From the Step Edit screen, turn the Master Encoder to select individual notes in a step. Once selected, the Note parameter will display at the bottom of the screen. Use the Note Soft Knob to change the note assigned to a specific lane of particular step.

#### **VELOCITY** *(1 to 127)*

Entering a Note creates a box that sits within the sequence grid for that specific step. The vertical height of this box within the grid indicates the Velocity Level of the note. Use the Velocity Soft Knob at the bottom of the screen to change the Velocity Level of the Note assigned to a specific lane of particular step.

#### **GATE** *(1% to 100%)*

Entering a Note creates a box that sits with in the sequence grid for that specific step. The horizontal width of this box within the grid the width indicates the Gate Time of the Note. Use the **GATE** Soft Knob at the bottom of the screen to change Gate Time of the Note assigned to a specific lane of particular step.

#### **RATCHET** *(1 to 4)*

Ratcheting allows the Sequencer to re-articulate a note multiple times inside of a single step; a sort of sequence stutter mode. This is an excellent tool for creating multiple triggers of the same note without using up multiple steps. The Ratchet Soft Knob at the bottom of the screen is used to control the number of “Ratchets” for the selected Note. A value of 1 equals no ratcheting.

### EDITING MULTIPLE NOTES

Pressing the ROW UP button until it reaches the the current Step number will highlight and select all of the Notes on the current step. The Velocity Level, Gate Time and Ratchet Count can be adjusted simultaneously using the Soft Knobs at the bottom of the screen. Rotating the Master Encoder to the right or left will restore the cursor to quickly select steps 1-64.

### DELETING NOTES

Any highlighted note in any lane, on any step, can be deleted using the **DELETE** button on the Front Panel. Using the Master Encoder to select an entire row of notes, and then pressing **DELETE** will remove all of the notes in that step. If a specific row has been selected with the Row Up or Row Down Soft buttons, pressing **SHIFT + DELETE** will remove the currently selected lane. Pressing the CLEAR SEQUENCE Soft Button on the Sequencer MORE page will initialize the Sequencer and eliminate all data from the active Sequence.



## SEQUENCER (Continued)

The screenshot shows the 'MODULATIONS' screen for 'SYNTH 1 - SEQUENCER'. It features a 4-lane modulation sequence over 16 steps. The lanes are: LADDER FILTER CUTOFF, OSCILLATOR 2 BEAT FREQ, OSCILLATOR 2 PULSE, and OSCILLATOR 2 MIX. An 'OFFSET' field at the bottom is set to 0%.

Step	Lane 1: LADDER FILTER CUTOFF	Lane 2: OSCILLATOR 2 BEAT FREQ	Lane 3: OSCILLATOR 2 PULSE	Lane 4: OSCILLATOR 2 MIX
1	-29	-52	-93	-78
2	-64	+85	+100	-29
3	-93	+21	+77	-65
4	+50	+50	+50	
5				
6				
7				
8				
9				
10				
11				
12				
13				
14				
15				
16				

OFFSET: 0%

### ENTERING MODULATION DATA (Step Edit Mode)

Each step of the sequence can also be assigned a number of modulation routings. Moog One handles these modulation values by creating an offset value that is combined with other values affecting the same parameters. This allows the performer to manually sweep a knob value, without the Sequencer constantly interrupting the sweep with absolute values stored for each step. These offsets are bipolar, meaning they can apply a positive or a negative amount of change to the

parameter value, and they are proportional, being expressed as a percentage value.

As with entering and editing notes, the Modulation routings are applied using lanes. Each lane is limited to one Modulation destination. While the CONTROLLER, AMOUNT, CATEGORY, and DESTINATION Parameters set with the Soft Knobs found at the bottom of the screen are universal for the selected lane, the OFFSET values are set for each individual step.

### ENTERING MODULATION DATA IN REAL TIME

By far, the simplest way to add modulation data to the sequence is by using the Step Mod function to record the changing value of a particular parameter as the Sequencer is running – either while recording or playing back. With the sequence stopped, the Step Mod method can be used to quickly edit modulation values in the STEP EDIT page. If it is not already open, press the **STEP EDIT** button to open the MODULATION SEQUENCE page. Press the MODULATIONS Soft Button at the top of the screen to open the MODULATION SEQUENCE screen.

**NOTE:** Using the STEP MOD function does not require opening the STEP EDIT page or pressing the MODULATIONS Soft Button; but doing so will allow you to see – and edit – the data entered in this manner.

Now press the **STEP MOD** button (the button will light) in the Sequencer module on the Front Panel and tweak any modulate-able parameter on the Front Panel. This will instantly set up a new Modulation lane using that parameter as the destination. While you can manually advance from step to step and change each value individually, you can also set the Sequencer to run, and twist and tweak away on that same parameter knob. The changing values will be recorded automatically for each step. Tweaking additional knobs will instantly set up a new Modulation lane for each destination, with the values again being recorded automatically for each step.

## SEQUENCER *(Continued)*

### ENTERING MODULATION DATA IN STEP TIME

While not as convenient as the Step Mod method, the manual entry mode allows you to address each step individually, and to assign modulation destinations that do not have a corresponding Front Panel knob – SVF Filter Spacing, for example. Here you will have to set up a Modulation lane, select a Sequencer step, and dial in an offset value. If it is not already selected, press the MODULATIONS Soft Button at the top of the screen. Press the ROW DOWN Soft button and then press down on the MASTER ENCODER to create the first Modulation lane for your sequence. Using the Soft Knobs at the bottom of the screen, set a modulation destination by adjusting the CATEGORY and DESTINATION values. The Destination options are dependent on the selected Category.

In addition, a CONTROLLER can also be assigned to the Modulation parameter occupying a specific lane. If no Controller is chosen, the Offset values will be applied at full strength to the destination parameter. However, assigning a Controller – and a percentage AMOUNT value – allows the strength of the sequenced modulation to be articulated as part of a performance. At an Amount value of 0%, the assigned Controller will have no effect. Using an Amount value of 100%, the assigned Controller can fully attenuate the sequenced modulation value, when the Controller is at its minimum position (value).

See the appendix at the end of this chapter for the possible values. Once these values have been set, press down on the Master Encoder for any desired step and use the OFFSET Soft knob to set the OFFSET amount for each sequence step. Press the ROW DOWN Soft button and then press down on the MASTER ENCODER to create a new Modulation lane. Repeat the same procedure for assigning a modulation destination to your Modulation routing lane, and for setting the offset values for each step.

### EDITING MODULATION DATA

The CONTROLLER, AMOUNT, CATEGORY, and DESTINATION of each modulation lane can be freely edited, as can the individual OFFSET values. As you enter OFFSET values, You can use the **◀ ADV ▶** buttons to move from step to step, or you can turn the Master Encoder to scroll left/right through the steps. Two soft buttons at the top of the screen allow you to move the selection Up or Down between rows (Lanes). You can also navigate up and down by turning the Master Encoder while SHIFT is active.

### EDITING MULTIPLE OFFSET VALUES

For any sequence step that has Modulation data in more than one lane, pressing the ROW UP Soft button until the current Step is selected will highlight and select all of the lanes in that step. The OFFSET values can be adjusted simultaneously using the Soft Knob at the bottom of the screen. Pressing the ROW DOWN Soft button will cause the cursor to select only one lane at a time. Continue to rotate the Master Encoder to the right to move between steps.

### DELETING MODULATION DATA

Any highlighted OFFSET value in any lane, on any step can be deleted using the **DELETE** button on the Front Panel. Selecting multiple OFFSET values and then pressing **DELETE** will remove all of the OFFSET values at that step. Pressing **SHIFT + DELETE** will remove the currently selected lane. Pressing the CLEAR SEQUENCE Soft Button on the Sequencer MORE page will initialize the Sequencer and eliminate all data - Notes and Modulation - from the active Sequence.

# SEQUENCER *(Continued)*

## STEP EDIT MODULATION APPENDIX

### CONTROLLERS

NONE
MOD WHEEL
PITCH WHEEL
PAD X
PAD Y
PAD PRESSURE
PAD GATE
VELOCITY
AFTERTOUCH
KEY PITCH
KB GATE
SUSTAIN
EXP 1
EXP 2
CV IN 1
CV IN 2
FILTER EG
AMPLIFIER EG
MODULATION EG
LFO 1
LFO 2
LFO 3
LFO 4
RANDOM
CONSTANT

### CATEGORY/DESTINATION

<b>ALL OSCS</b>	<b>SVF FILTER</b>
PITCH 1 LFO	CUTOFF
PITCH EG MOD	RESONANCE
TRIANGLE LFO 3 MOD	SPACING
PULSE LFO 3 MOD	EG AMOUNT
FM AMOUNT	LFO 2 AMOUNT
<b>OSC 1, 2, 3</b>	FM AMOUNT
<b>OCTAVE</b>	<b>LADDER FILTER</b>
FREQUENCY	CUTOFF
BEAT	RESONANCE
SAW	EG AMOUNT
TRIANGLE	LFO 2 AMOUNT
PULSE	FM AMOUNT
<b>MIX</b>	<b>EG 1, 2, 3</b>
<b>NOISE</b>	DELAY
COLOR MIX	ATTACK
ATTACK	HOLD
SUSTAIN	DECAY
RELEASE	SUSTAIN
<b>VCA</b>	RELEASE
LEVEL	MULTI TRIGGER
PAN	SYNC
<b>FILTERS</b>	LOOP
SVF/LADDER MIX	LATCH
	<b>LFO 1, 2, 3, 4</b>
	RATE
	WAVEFORM
	VARIATION
	DELAY
	RAMP UP TIME
	RAMP DOWN TIME

## SEQUENCER *(Continued)*

### SEQUENCER MORE PAGE

Pressing the triangular **MORE** button in the upper right corner of the Sequencer module will reveal a second level of parameters than can be accessed and modified using the interactive portion of the Center Console. The left pane represents the sequenced data. The right pane shows the current values of the Front Panel parameters for this module. The additional MORE parameters are displayed in the bottom portion of the screen.

**NOTE:** Pressing the (now) illuminated **MORE** button will exit the MORE page and recall the HOME screen.

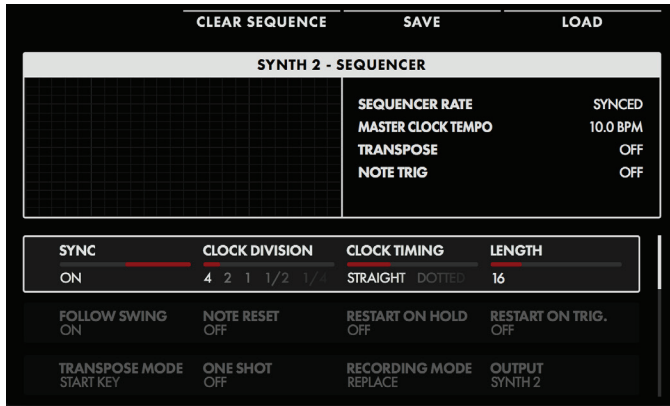

The onscreen MORE page parameters are edited using the four Soft Knobs below the screen.

### CHANGING THE VALUE

Rotate the Soft Knob below the parameter name to change its value. In some cases, the Soft Knob simply turns a function on or off. In other cases, the Soft Knob may choose from a list of values or settings, and in other cases, the Soft Knob is dialing in a value – either absolute or a percentage.

### SELECTING A ROW

The scroll bar at the right edge indicates the current row. Rotate the Master Encoder to the right to highlight the next row of parameters. Rotating the Master Encoder to the left will select a previous row. Again, rotate the Soft Knob below the parameter to change its value.

### SYNC *(OFF, ON)*

When Sync is Off, the Sequencer is free to run at its own tempo. When Sync is On, the Sequencer and Master Clock are synchronized, and the Master Clock determines the Sequencer tempo.

**NOTE:** When SYNC ON is selected here, rotating the Sequencer **RATE** knob on the Front Panel will select quantized clock divisions (see below) of the Master Clock.

### CLOCK DIVISION *(4, 2, 1, 1/2, 1/4, 1/8, 1/16, 1/32)*

When Sync is On, the Master Clock provides a tempo base; and choosing a clock division of that tempo base sets the Sequencer speed. When Sync is Off, this parameter instead selects a clock division of the tempo set by the Sequencer **RATE** knob on the front panel. Changing the value of the CLOCK DIVISION parameter specifies the timing in terms of quarter-note beats.

### CLOCK TIMING *(STRAIGHT, DOTTED, TRIPLET)*

Clock Timing provides a further modification of the step duration, allowing for a wider selection of note timings relative to the Master Clock tempo (Sync On) or the Sequencer Rate tempo (Sync Off). Here the timing of each note played can be set relative to the tempo.

#### STRAIGHT

The timing of each step is played as specified by the CLOCK DIVISION parameter.

#### DOTTED

The timing of each step is modified to play as a dotted note, or at 1.5 x the value specified by the CLOCK DIVISION parameter.

#### TRIPLET

The timing of each step is modified to play as if it were one note in a triplet, or at 2/3rds of the value specified by the CLOCK DIVISION parameter.

## SEQUENCER *(Continued)*

### LENGTH *(1 to 64)*

By changing the Length, the sequence can be set to contain any number of steps, from 1 to 64. Combined with the CLOCK TIMING parameter, it is possible to generate sequences of differing lengths, feels, and time signatures.

### FOLLOW SWING *(OFF, ON)*

The Master Clock includes parameters related to adding swing to the beat. When Sync'd to the Master Clock, the Sequencer can either follow this swing information, or ignore it and play strictly to the BPM setting.

### NOTE RESET *(OFF, ON)*

This parameter specifies how the timing of the Sequencer will behave when a new note is played on the keyboard, if the **NOTE TRIG** button in the Sequencer module is also On (lit). When this NOTE RESET parameter is On, the Sequencer begins instantly, resetting the downbeat timing of the current Clock Division to match the note as it is played. When Note Reset is Off, the Sequencer will wait for the start of the next specified Clock Division before the pattern begins.

### RESTART ON HOLD *(OFF, ON)*

This parameter specifies how the timing of the Sequencer will behave when the **HOLD** button on the Front Panel is On (lit) and the **NOTE TRIG** button in the Sequencer module is also On (lit). When this RESTART ON HOLD parameter is On, playing any new note – with no other notes held down – will reset the sequence to begin playing from the first step. When this RESTART ON HOLD parameter is Off, playing any new note will not restart the sequence.

**NOTE:** *If the RESTART ON HOLD parameter is off, and the **HOLD**, **NOTE TRIG**, and **TRANSPOSE** buttons from the Sequencer module area all set to On, then playing a new note while a previous note is still held will transpose the sequence without resetting back to step one.*

### RESTART ON TRIG *(OFF, ON)*

This RESTART ON TRIG (Restart On Note Trigger) parameter specifies how the timing of the Sequencer will behave when the **NOTE TRIG** button in the Sequencer module on the Front Panel is On (lit). When this Restart On Note Trigger parameter is set to On, then using the Note Trigger feature to initiate the sequence playback will always reset the sequence to restart at step one. When this Restart On Note Trigger parameter is set to Off, using the Note Trigger feature to initiate the sequence playback will resume the playback of the sequence from the active step.

### TRANSPOSE MODE *(START KEY, INTERVAL)*

When the **TRANSPOSE** button in the Sequencer module on the Front Panel is set to On (lit), the playback of the sequence can be transposed. There are two methods for determining the transpose amount.

#### **START KEY**

Using the Start Key method, any key can be chosen to serve as the starting note of the sequence, and the remaining notes will also be transposed by the same amount to preserve their correct intervals in relation to the new Start Key.

#### **INTERVAL**

The Interval method uses Middle C on the keyboard as a reference point, and allows the sequence to be transposed by a specific interval, regardless of the original key. In this way, playing F above Middle C would transpose the sequence up a fourth. Even if the original key and starting note was not C, the transposition would still be equal to a fourth, so E would become A, etc.

## SEQUENCER *(Continued)*

### ONE SHOT *(OFF, ON)*

Once the sequence begins to play, it can play to the end and stop (One Shot On), or it can play to the end and then loop around and restart from the beginning (One Shot Off). This looping behavior is the way most sequencers operate, but the addition of the One Shot option allows an intricate sequence pattern to be launched at will, anywhere in the song, and play through only once – although the One Shot playback can be launched numerous times. This is a great way to add a live flourish of notes when transitioning from verse to chorus, playing a signature lick perfectly every time, etc.

### RECORDING MODE *(REPLACE, OVERDUB)*

Once a sequence has been recorded, there are two ways that the sequencer can respond to new notes being recorded over existing notes.

#### REPLACE(DEFAULT)

Newly recorded notes will replace any previously notes recorded on the same step.

#### OVERDUB

Newly recorded notes are added to the notes that were already there, without replacing the existing information.

### OUTPUT *(SYNTH 1/2/3, ALL SYNTHS)*

This setting controls which Synth(s) will play in response to this sequence. The options are either the currently selected Synth (Synth 1, 2, or 3), or ALL SYNTHS. The ALL SYNTHS option can be used to create a single sequence that will play all the parts of a split or layered sound.

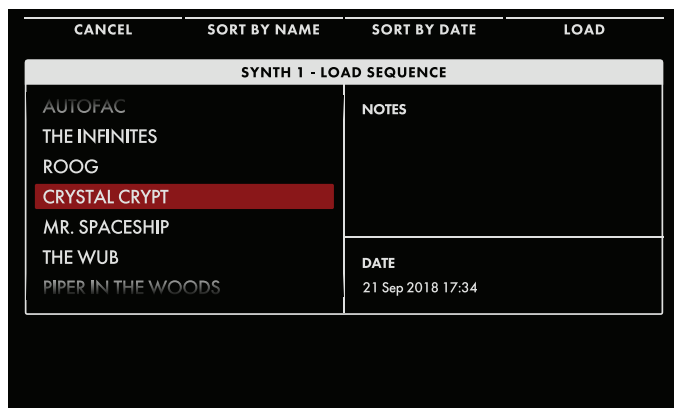

### LOADING A SEQUENCE

Pressing the LOAD Soft Button at the top of the screen will open the Load Sequence screen.

The left pane will show a list of all of the available Sequences. To make it easier to locate a saved Sequence, this list can be sorted by name by pressing the SORT BY NAME Soft Button at the top of the screen. The Sequence list can also be sorted by the date the sequence was most recently saved, using the SORT BY DATE

Soft Button. The upper right pane will display any performance notes that were added to and saved along with Sequence. The lower right pane will display a date stamp of when the selected Sequence was most recently saved to memory.

Rotate the Master Encoder to highlight and select a specific Sequence, then press the LOAD Soft Button at the top of the screen. A small indicator will appear next to the Sequence name, showing that it is the active Sequence. Once the Sequence is loaded, you can play it, change the Sequence settings found in the Sequencer MORE page, or press the **STEP EDIT** button to open the Step Edit window to edit the content of the sequence.

**TIP:** When the PRESET AUTOLOAD function [SETTINGS / GLOBAL / HARDWARE SETTINGS] is set to ON, rotating the Master Encoder will automatically load the selected Sequence as you scroll through the list, without the need to use the LOAD Soft Button.

## SEQUENCER (Continued)

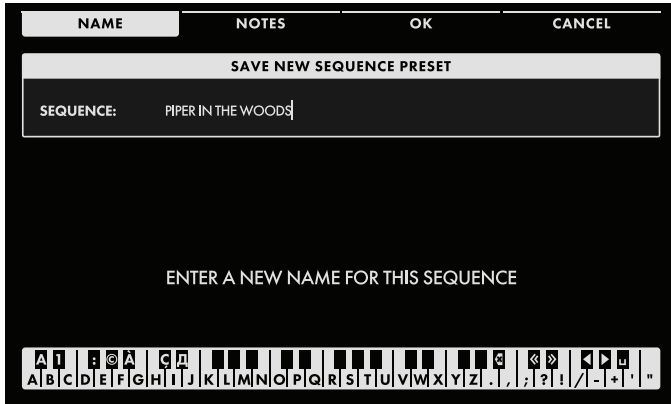

### SAVING A SEQUENCE

Once you have finished creating and/or editing your Sequence, press the SAVE Soft Button at the top of the screen. Here you can name your edited Sequence.

When the SAVE screen opens, the NAME Soft Button will already be selected, and the screen prompt will ask you to name the current sequence.

### ENTERING TEXT

Moog One allows you to enter names and text directly from the keyboard. The white keys (naturals) enter the characters; certain black keys (accidentals) have specific functions.

- Keys C#1 - D#2 select the character set.
- Key F#4 removes the current name and randomly generates a new name.
- Key G#4 clears all the characters in the screen.
- Key A#4 deletes the character to the left of the cursor.
- Keys C#5 and D#5, respectively, change the character immediately preceding the cursor to the previous or next symbol in the current character set, changing an M to an L or an N, for example with a single key press.
- Keys F#5 and G#5 move the cursor left or right, respectively.
- Key A#5 adds a space.

**NOTE:** The note numbers given above relate to the onscreen keyboard, and do not reflect the key's actual MIDI Note number, etc.

**TIP:** You can also enter names directly, using a standard USB keyboard connected to the Moog One **USB HOST** port.

Once you have entered a name for the sequence, you can also enter any optional performance notes using the same method. These notes can be quick reminders or application cues, such as "Starts on F#" or "Use as the intro for Song 5" or "Launch sequence on last note of the bass solo," etc. Press the NOTES Soft Button and follow the screen prompts, using the same text entry method.

After naming the sequence and adding any performance notes, press the OK Soft Button to save the sequence, or press the CANCEL Soft Button to exit the Sequence SAVE screen without saving.

## EFFECTS

Moog One offers an extensive array of digital effects. Up to three individual Synth Effects (one per Synth), and up to two Master Effects can all be operating at once. The Master Effects include a number of premium studio-grade effects created by and licensed from renowned audio processing pioneer, Eventide®. With the exception of these Eventide Master Effects, the Master Effect List is identical to the Synth Effect list, and Synth Effects can be recalled and used as Master Effects as well – and vice-versa. These digital effects are the only part of the Moog One audio path that is not in the analog domain. All assigned Synth Effects and Master Effects are saved as part of the Preset. To create a pure all-analog audio path, simply turn off the **SYNTH EFFECT** and **MASTER EFFECTS ON** buttons.

### UNDERSTANDING SYNTH EFFECTS

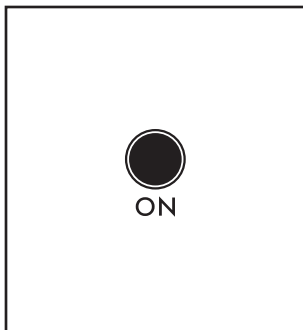

#### **ON** (ON/LIT, OFF/UNLIT)

The **ON** button toggles the **SYNTH EFFECT** module On and Off; when the button is lit, the Synth Effect is On.

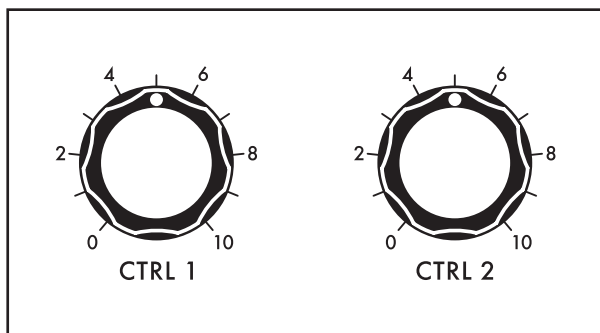

#### **CTRL 1 AND CTRL 2 KNOB**

Synth Effects are applied individually; each Synth has access to its own individual Synth Effect. Once a Synth Effect is applied, any two effect parameters can be controlled in real time from the Front Panel using the **CTRL 1** knob and **CTRL 2** knob. Both of these knobs will be pre-assigned to the two most-likely-to-be-tweaked parameters in each Effect, but they can be easily re-assigned to any available parameter by using the **EFFECT TYPE** page. The status of the **ON** button and the value of the **CTRL 1** and **CTRL 2** knobs are saved as part of the Timbre.

### SYNTH EFFECT STRUCTURE

Synth Effects are classified by type – Delay, Chorus, Flanger, etc. Once a particular type of effect has been selected and loaded, the individual parameters may be adjusted, and your settings can be saved as a Synth Effect Preset of that effect type. For example, if you select and load a Flanger-type Synth Effect and tweak all of the parameters to your liking, you can save it as a Synth Effect Flanger, and give it a name (such as MY SWEET FLANGER) so you can recall it and reuse it again and again.

The structure of the Synth Effect uses a monoaural input and a stereo output; this stereo output is mixed with the stereo **MAIN L/R** buss and/or the **SUB L/R** buss. The first parameter of every Synth Effect is the MIX parameter, which sets a balance between the Wet (affected) and Dry (unaffected) signal.

**TECHNICAL NOTE:** Although PAN can be assigned as a modulation destination using the Modulation Matrix (allowing the panning of individual voices as they are played), this per-voice panning cannot be preserved in the monoaural buss feeding the Synth Effect. The per-voice panning will continue to affect the Dry (unprocessed) signal, but the Wet (processed) signal will rely on the Synth pan position, as determined by the VCA MORE page settings.



## EFFECTS *(Continued)*

### SYNTH EFFECT MORE PAGE

Pressing the triangular **MORE** button in the upper right corner of the SYNTH EFFECT module will open the Synth Effect MORE page. Using the Soft Buttons at the top of the screen, you can open a list of EFFECT TYPES, LOAD a previously saved Synth Effect Preset; adjust the EFFECT PARAMETERS (PARAMS) of the current Synth Effect; and SAVE your edits as a Synth Effect Preset.

**NOTE:** Pressing the (now) illuminated **MORE** button will exit the MORE page and recall the HOME screen.

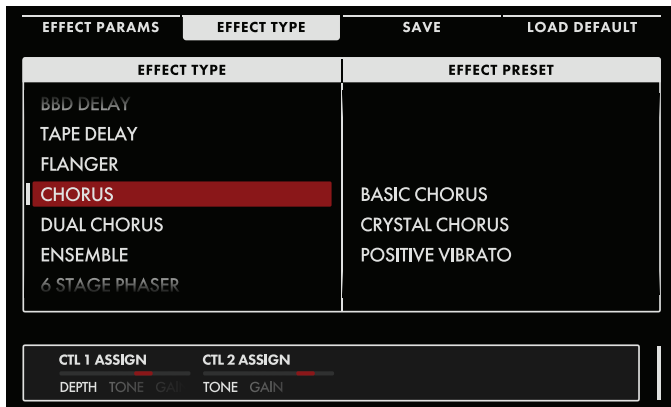

### SELECTING AND LOADING A SYNTH EFFECT

If it is not already selected, Press the EFFECT TYPE Soft Button at the top of the screen to reveal all of the Synth Effects stored in Moog One. The left pane shows a list of all the different Effect Types. Rotate the Master Encoder to highlight an Effect Type; the right pane shows all of the available Effect Presets of that Type. Pressing down on the Master Encoder will move the red-colored cursor to the right pane; rotate the Master Encoder to select and highlight a specific Effect Preset,

and press down once again on the Master Encoder to load the Effect. A white vertical bar will appear before the Effect name to indicate the Effect has been loaded. Press the BACK Soft Button at the top of the screen to return the cursor to the left pane to select a different Effect Type. To load an initialized Effect Type, use the Master Encoder to select an Effect Type and press the LOAD Soft Button to call up a default version of that Effect Type.

**TIP:** When the PRESET AUTOLOAD function [SETTINGS / GLOBAL / HARDWARE SETTINGS] is set to On, scrolling from one entry to the next in either pane will load the selected Effect Preset automatically, without the need to press down on the Master Encoder.

### CHANGING AND EDITING THE SYNTH EFFECT PARAMETER VALUES

Press the EFFECT PARAMS (Effect Parameters) Soft Button at the top of the screen. The left pane shows a graphic image of the components that make up the active Synth Effect. The right pane shows the parameters assigned to the **CTRL 1** and **CTRL 2** knobs on the Front Panel, and their current values. The bottom portion of the screen shows all the editable parameters for the active Synth Effect. You are free to change the value of any and all of these parameters to customize the Synth Effect to match your needs or performance.

## EFFECTS (Continued)

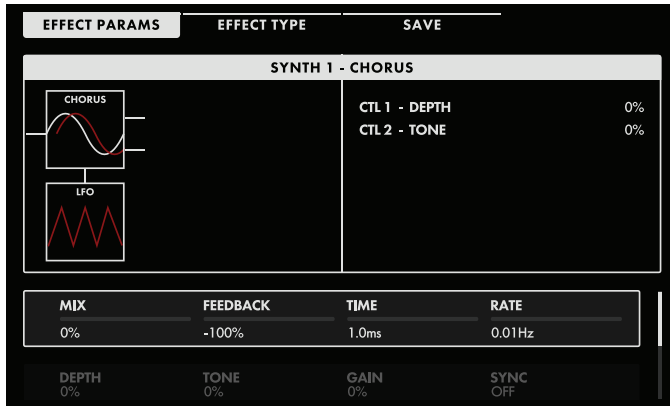

row of parameters. Rotating the Master Encoder to the left will select a previous row. Again, rotate the Soft Knob below the parameter to change its value.

**NOTE:** Each Synth Effect Type has its own distinct set of editable parameters. A list of the onboard effects – including all editable parameters and the parameters pre-assigned to the **CTRL 1** and **CTRL 2** knobs – is found in the **EFFECTS APPENDIX** (page 102-110).

**NOTE:** The last parameter listed for each Synth Effect is **SYNC**. When the **SYNC** parameter is set to On, the time-based parameter values will switch from absolute values to clock-division values of the Master Clock tempo.

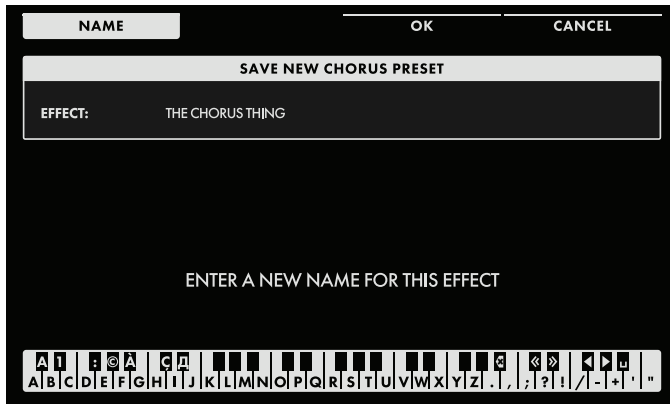

- Keys C#1 - D#2 select the character set.
- Key F#4 removes the current name and randomly generates a new name.
- Key G#4 clears all the characters in the screen.
- Key A#4 deletes the character to the left of the cursor.
- Keys C#5 and D#5, respectively, change the character immediately preceding the cursor to the previous or next symbol in the current character set, changing an M to an L or an N, for example with a single key press.
- Keys F#5 and G#5 move the cursor left or right, respectively.
- Key A#5 adds a space.

**NOTE:** The note numbers given above relate to the onscreen keyboard, and do not reflect the keys actual MIDI Note number, etc.

**TIP:** You can also enter names directly, using a standard USB keyboard connected to the Moog One's **USB HOST** port.

Press the OK Soft Button to save your Effect Preset under this new name. Press the CANCEL Soft Button to exit without saving.

### CHANGING THE VALUE

Rotate the Soft Knob below the parameter name to change its value. In some cases, the Soft Knob simply turns a function On or Off. In other cases, the Soft Knob may choose from a list of values or settings, and in other cases, the Soft Knob is dialing in a value – either absolute or a percentage.

### SELECTING A ROW

The scroll bar at the right edge indicates the current row. Rotate the Master Encoder to the right to highlight the next

row of parameters. Rotating the Master Encoder to the left will select a previous row. Again, rotate the

Soft Knob below the parameter to change its value.

### SAVING AN EDITED EFFECT

Once you have made all of your edits to the Effect, press the SAVE Soft Button at the top of the screen. Here you can name your edited Effect.

### ENTERING TEXT

Moog One allows you to enter names and text directly from the keyboard. The white keys (naturals) enter the characters; certain black keys (accidentals) have specific functions.

# MASTER EFFECTS

## UNDERSTANDING MASTER EFFECTS

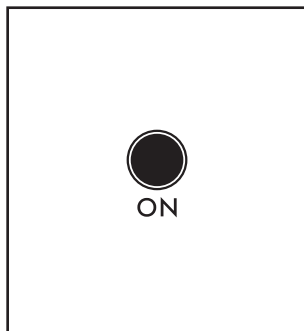

### ON (ON/LIT, OFF/UNLIT)

The **ON** button toggles the SYNTH EFFECT module On and Off; when the button is lit, the Synth Effect is On.

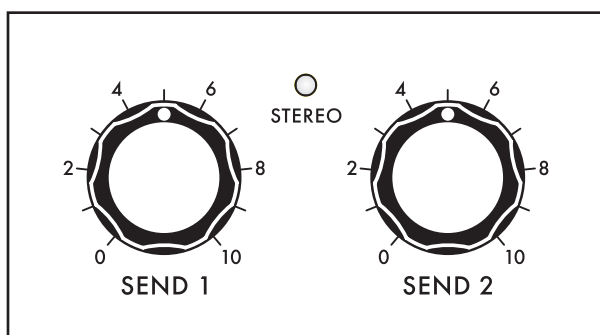

### SEND 1 AND SEND 2 KNOB

Unlike the Synth Effects, which are applied per Synth, Master Effects are available to any and all Synths within the active Preset. The **SEND 1** and **SEND 2** knobs located on the Front Panel determine how much signal from each individual Synth is being fed into the Master Effect Bus. The status of the **ON** button and the value of the **SEND 1** and **SEND 2** knobs are saved as part of the Timbre.

The Master Effects buss offers two inputs and two outputs, allowing the Master Effects to be configured to operate as one stereo in/stereo out processor (STEREO), or as two mono in/stereo out processors (DUAL MONO). When the MASTER BUSS MODE parameter in the Master Effects MORE page is set to STEREO, the STEREO LED indicator will light.

**TECHNICAL NOTE:** Although PAN can be assigned as a modulation destination using the Modulation Matrix (allowing the panning of individual voices as they are played), this per-voice panning cannot be preserved in the dual mono buss feeding the Master Effects. The per-voice panning will continue to affect the Dry (unprocessed) signal, but the Wet (processed) signal will rely on the Synth pan position, as determined by the VCA MORE page settings. However, in the Stereo mode, the inputs to the Master Effects are stereo, and the per-voice panning data is preserved.

Included in the Master Effects are select studio-grade effects created by Eventide®, and licensed for Moog One use. Due to their innate complexity, only one of these premiere Eventide effects may be used at a time, even when the Master Effects are configured in the Dual Mono mode. A second Master Effect may indeed still operate alongside the Eventide effect; the limitation is only that no two Eventide effects can operate simultaneously.

**NOTE:** If one of the Eventide effects is already assigned to one of the Master Effects, say Master Effect 1, then the Eventide effects will appear grayed-out in the EFFECT 2 TYPE list, and they will be unselectable.

## EFFECTS *(Continued)*

### MASTER EFFECTS MORE PAGE

Pressing the triangular **MORE** button in the upper right corner of the MASTER EFFECTS module will open the Master Effects MORE page. Using the Soft Buttons at the top of the screen, you can open a list of EFFECT TYPES, LOAD a previously saved Master Effect Preset; adjust the EFFECT PARAMETERS (PARAMS) of the current Master Effect; and SAVE your edits as a Master Effect Preset.

**NOTE:** Pressing the (now) illuminated **MORE** button will exit the MORE page and recall the HOME screen.

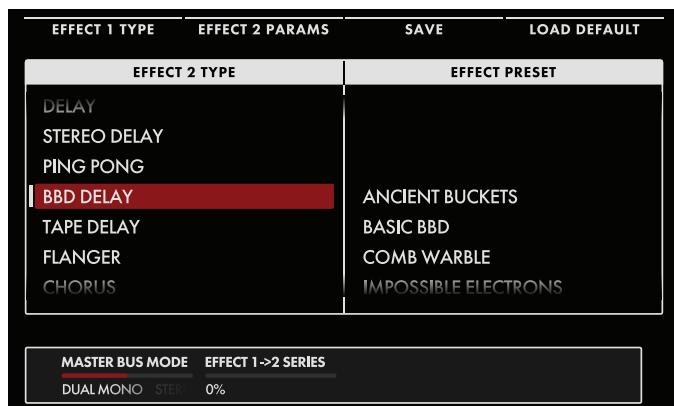

### MASTER BUSS MODE *(DUAL MONO, STEREO)*

Press any of the EFFECT TYPE Soft Buttons at the top of the screen, and rotate the Soft Knob at the lower left corner of the screen to select a mode.

#### STEREO

In this configuration, one Master Effect is available; using a stereo input and a stereo output. When this parameter is set to STEREO, the **STEREO** LED indicator in the Master Effects module on the Front Panel will be lit.

#### DUAL MONO

In this configuration, two Master Effects are available; each using a monoaural input and a stereo output.

#### STEREO WIDTH *(0% to 100% to 200%)*

The algorithm controlled by this parameter determines the width of the stereo image created by the Master Effects. At the 0% setting, the stereo image is, in fact, monoaural. Rotating the Soft Knob to the left will increase the value of this parameter. At 100%, the default stereo image is restored. Increasing the value even further enhances the stereo effect, up to the maximum setting of 200%.

**NOTE:** The STEREO WIDTH process is applied at the very end of the MASTER EFFECTS signal chain, and is unaffected by the TYPE of MASTER EFFECT chosen. This Setting affects both the MAIN OUT and SUB OUT mixes.

#### EFFECT 1 → 2 SERIES *(0% to 100%)*

This parameter is only available in the DUAL MONO mode. Setting this parameter to a value of 0% places the two Master Effects side by side, running in parallel. The stereo outputs of both processors are summed with the main output. By increasing this value, more and more of the output of Master Effect 1 is being fed to the input of Master Effect 2. When this value reaches 100%, the Master Effects are truly in series, and the entire output of Master Effect 1 is fed to the input of Master Effect 2; only the output of Master Effect 2 is summed with the main output.

## SELECTING AND LOADING A MASTER EFFECT

If it is not already selected, press either the EFFECT 1 TYPE or EFFECT 2 TYPE Soft Buttons at the top of the screen. The left pane shows a list of all the different Effect Types; the right pane shows all of the available Effect Presets of that Type.

**NOTE:** There is only one EFFECT TYPE list when the MASTER BUSS MODE is set to STEREO.

**TIP:** With the exception of the Eventide Master Effects, the Master Effect List is identical to the Synth Effect list, and Synth Effect Presets can be recalled and used as Master Effects as well – and vice-versa.

Rotate the Master Encoder to highlight and select an Effect Type from the list. Pressing down on the Master Encoder will move the red-colored cursor to the right pane; rotate the Master Encoder to select and highlight a specific Effect Preset, and press down once again on the Master Encoder to load the Effect. A white vertical bar will appear before the Effect name to indicate the Effect has been loaded. Press the BACK Soft Button at the top of the screen to return the cursor to the left pane to select a different Effect Type. To load an initialized Effect Type, use the Master Encoder to select an Effect Type and press the LOAD Soft Button to call up a default version of that Effect Type.

**TIP:** When the PRESET AUTOLOAD function [SETTINGS / GLOBAL / HARDWARE SETTINGS] is set to ON, scrolling from one entry to the next in the Effect Preset list will load the selected Effect Preset automatically, without the need to press down on the Master Encoder.

## CHANGING & EDITING THE MASTER EFFECT PARAMETER VALUES

Press the EFFECT 1 PARAMS or EFFECT 2 PARAMS (Effect Parameters) Soft Button at the top of the screen. The left pane shows a graphic image of the components that make up the active Master Effect. The right pane shows the value of the **SEND 1** or **SEND 2** knob for each of the three Synths. The bottom portion of the screen shows all the editable parameters for the active Master Effect. You are free to change the value of any and all of these parameters to customize the Master Effect to match your needs or performance.

**NOTE:** There is only one EFFECT PARAMS list when the MASTER BUSS MODE is set to STEREO.

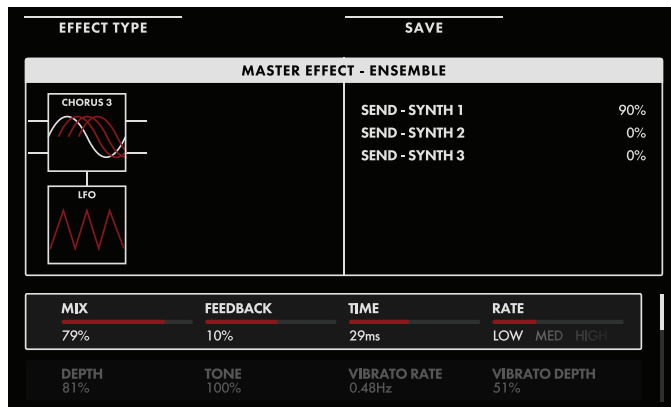

## CHANGING THE VALUE

Rotate the Soft Knob below the parameter name to change its value. In some cases, the Soft Knob simply turns a function on or off. In other cases, the Soft Knob may choose from a list of values or settings, and in other cases, the Soft Knob is dialing in a value – either absolute or a percentage.

## SELECTING A ROW

The scroll bar at the right edge indicates the current row. Rotate the Master Encoder to the right to highlight the next row of parameters. Rotating the Master

Encoder to the left will select a previous row. Again, rotate the Soft Knob below the parameter to change its value.

**NOTE:** Each Effect Type has its own distinct set of editable parameters. A list of the onboard effects – including all editable parameters – is found in the EFFECTS APPENDIX.

**NOTE:** With the exception of the Eventide Master Effects, the last parameter listed for each Effect is SYNC. When the SYNC parameter is set to On, the time-based parameter values will switch from absolute values to clock-division values of the Master Clock tempo.

## EFFECTS *(Continued)*

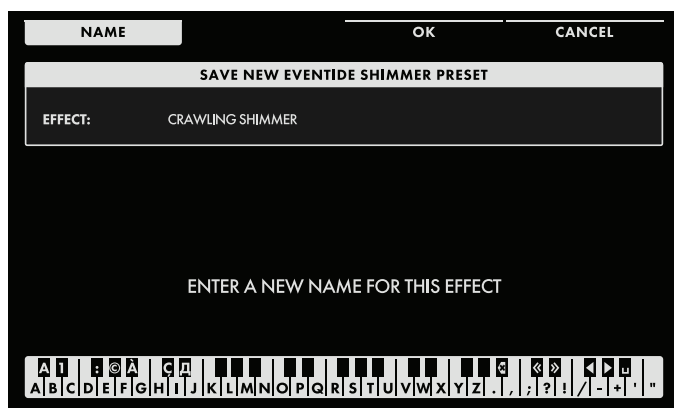

### SAVING AN EDITED EFFECT

Once you have made all of your edits to the Effect, press the SAVE Soft Button at the top of the screen. Here you can name your edited Effect Preset.

### ENTERING TEXT

Moog One allows you to enter names and text directly from the keyboard. The white keys (naturals) enter the characters; certain black keys (accidentals) have specific functions.

- Keys C#1 - D#2 select the character set.
- Key F#4 removes the current name and randomly generates a new name.
- Key G#4 clears all the characters in the screen.
- Key A#4 deletes the character to the left of the cursor.
- Keys C#5 and D#5, respectively, change the character immediately preceding the cursor to the previous or next symbol in the current character set, changing an M to an L or an N, for example with a single key press.
- Keys F#5 and G#5 move the cursor left or right, respectively.
- Key A#5 adds a space.

Press the OK Soft Button to save your Effect Preset under this new name. Press the CANCEL Soft Button to exit without saving.

*This page left intentionally blank*

## EFFECTS APPENDIX

**NOTE:** When the Sync parameter is set to On, the value of certain time-based parameters will automatically switch from absolute and variable ms values to clock-division values based the Master Clock. Fractional clock-division values will be presented in three different versions, 1/4T, 1/4, and 1/4., for example. In the first Triplet version, the timing is modified to play at 2/3rds of the Straight value. The second version is the Straight Value. In the third Dotted version, the timing is modified to play at 1.5 x the Straight Value.

The complete SYNC value range for the effects is:

{1/64T, 1/64, 1/64., 1/32T, 1/32, 1/32., 1/16T, 1/16, 1/16., 1/8T, 1/8, 1/8., 1/4T, 1/4, 1/4., 1/2T, 1/2, 1/2., 1, 2, 4}

### **DELAY** (Single Tap Digital Delay Line; Cubically Interpolated)

MIX	AMOUNT OF DELAY SIGNAL IN THE OUTPUT	0% to 100%	CTRL 1
FEEDBACK	DELAY SIGNAL FED BACK TO THE INPUT	0% to 100%	
TIME	DELAY TIME	0.1ms to 2000ms	CTRL 2
GAIN	GAIN STAGE OF THE PROCESSED SIGNAL	0% to 100%	
SYNC	SYNC ON OR OFF	ON, OFF	

### **STEREO DELAY** (Dual Tap Digital Delay Line; Cubically Interpolated with Stereo Spatialization)

PARAMETER NAME	PARAMETER DESCRIPTION	RANGE	ASSIGNED
MIX	AMOUNT OF DELAY SIGNAL IN THE OUTPUT	0% to 100%	CTRL 1
FEEDBACK	DELAY SIGNAL FED BACK TO THE INPUT	0% to 100%	CTRL 2
TIME LEFT	DELAY TIME FOR THE LEFT SIDE	0.1ms to 2000ms	
TIME RIGHT	DELAY TIME FOR THE RIGHT SIDE	0.1ms to 2000ms	
FEEDBACK LEFT	DELAY SIGNAL FED BACK TO THE LEFT CHAN	0% to 100%	
FEEDBACK RIGHT	DELAY SIGNAL FED BACK TO THE RIGHT CHAN	0% to 100%	
MOD RATE LEFT	MODULATION RATE LEFT CHAN	0% to 100%	
MOD RATE RIGHT	MODULATION RATE RIGH CHAN	0% to 100%	
MOD DEPTH LEFT	DEPTH OF MODULATION LEFT CHAN	0% to 100%	
MOD DEPTH RIGHT	DEPTH OF MODULATION RIGHT CHAN	0% to 100%	
TONE	LPF TONE CONTROL	0% to 100%	
GAIN	GAIN STAGE OF THE PROCESSED SIGNAL	0% to 100%	
SYNC	SYNC ON OR OFF	ON, OFF	



**PING PONG** *(Dual Tap Digital Delay Line; Cubically Interpolated with Alternating Stereo Spatialization)*

MIX	AMOUNT OF DELAY SIGNAL IN THE OUTPUT	0% to 100%	CTRL 1
FEEDBACK	DELAY SIGNAL FED BACK TO THE INPUT	0% to 100%	CTRL 2
TIME LEFT	DELAY TIME FOR THE LEFT SIDE	0.1ms to 2000ms	
TIME RIGHT	DELAY TIME FOR THE RIGHT SIDE	0.1ms to 2000ms	
OFFSET	DELAY TIME OFFSET BETWEEN LEFT & RIGHT	0% to 100%	
TONE	LPF TONE CONTROL	0% to 100%	
GAIN	GAIN STAGE OF THE PROCESSED SIGNAL	0% to 100%	
SYNC	SYNC ON OR OFF	ON, OFF	

**BBD DELAY** *(Single Tap Digital Delay; BBD (Bucket Brigade Delay) Emulation)*

MIX	AMOUNT OF DELAY SIGNAL IN THE OUTPUT	0% to 100%	CTRL 1
FEEDBACK	DELAY SIGNAL FED BACK TO THE INPUT	0% to 100%	
TIME	DELAY TIME	0.1ms to 2000ms	CTRL 2
NOISE	AMOUNT OF EMULATED BBD CLOCK NOISE	0% to 100%	
TONE	LPF TONE CONTROL	0% to 100%	
MOD	AMOUNT OF RANDOMNESS/MODULATION IN THE DELAY LINE	0% to 100%	
GAIN	GAIN STAGE OF THE PROCESSED SIGNAL	0% to 100%	
SYNC	SYNC ON OR OFF	ON, OFF	

**TAPE DELAY** *(Single Tap Digital Delay; Analog Tape Emulation)*

MIX	AMOUNT OF DELAY SIGNAL IN THE OUTPUT	0% to 100%	CTRL 1
FEEDBACK	DELAY SIGNAL FED BACK TO THE INPUT	0% to 100%	
TIME	DELAY TIME	0.1ms to 2000ms	CTRL 2
FLUTTER	FLUTTER RATE CONTROL	0% to 100%	
WOW	WOW DEPTH & SMALL RATE CONTROL MACRO	0% to 100%	
TAPE BIAS	HPF FILTER & TAPE BIAS VOICE MIXING	0% to 100%	
GAIN	GAIN STAGE OF THE PROCESSED SIGNAL	0% to 100%	
SYNC	SYNC ON OR OFF	ON, OFF	

**ECHO** (Single Tap Delay with Spring-Style Diffusion)

MIX	AMOUNT OF DELAY SIGNAL IN THE OUTPUT	0% to 100%	CTRL 1
TONE	LPF TONE CONTROL	0% to 100%	
TIME	DELAY TIME	0.1ms to 2000ms	CTRL 2
FEEDBACK	FEEDBACK PARAMETER FOR ECHO	0% to 100%	
ROOM	SPACE CONTROL FOR DIFFUSION TANK	0% to 100%	
DECAY	DECAY TAIL FOR DIFFUSION TANK	0% to 100%	
MOD RATE	RATE OF MODULATION	0.1Hz to 10Hz	
MOD DEPTH	DEPTH OF MODULATION	0% to 100%	
GAIN	GAIN STAGE OF THE PROCESSED SIGNAL	0% to 100%	
SYNC	SYNC ON OR OFF	ON, OFF	

**FLANGER** (Single Tap Digital Flanger)

MIX	AMOUNT OF FLANGED SIGNAL IN THE OUTPUT	0% to 100%	
FEEDBACK	FLANGED SIGNAL FED BACK TO THE INPUT	-100% to +100%	
TIME	FLANGED TIME	0.1ms to 15ms	
RATE	LFO RATE OF MODULATION	0.1Hz to 10Hz	CTRL 1
DEPTH	LFO DEPTH OF MODULATION	0% to 100%	CTRL 2
TONE	LPF CUTOFF CONTROL	0% to 100%	
NOISE	AMOUNT OF NOISE IN SIGNAL	0% to 100%	
SPREAD	STEREO SPREAD AMOUNT	0% to 100%	
GAIN	GAIN STAGE OF THE PROCESSED SIGNAL	0% to 100%	
SYNC	SYNC ON OR OFF	ON, OFF	

**CHORUS** (Single Tap Digital Chorus)

MIX	AMOUNT OF CHORUS SIGNAL IN THE OUTPUT	0% to 100%	
FEEDBACK	CHORUS SIGNAL FED BACK TO THE INPUT	-100% to +100%	
TIME	CHORUS TIME	0.1ms to 50ms	
RATE	LFO RATE OF MODULATION	0.1Hz to 20Hz	CTRL 1
DEPTH	LFO DEPTH OF MODULATION	0% to 100%	CTRL 2
TONE	LPF CUTOFF CONTROL	0% to 100%	
SPREAD	STEREO SPREAD AMOUNT	0% to 100%	
GAIN	GAIN STAGE OF THE PROCESSED SIGNAL	0% to 100%	
SYNC	SYNC ON OR OFF	ON, OFF	

**DUAL CHORUS** (*Dual Tap Digital Chorus; Bi-Phase Implementation*)

MIX	AMOUNT OF CHORUS SIGNAL IN THE OUTPUT	0% to 100%	CTRL 1
FEEDBACK	CHORUS SIGNAL FED BACK TO THE INPUT	-100% to +100%	CTRL 2
TIME	TIME OFFSET	3ms to 60ms	
DEPTH	LFO DEPTH OF MODULATION	0% to 100%	
RATE	LFO RATE OF MODULATION	LOW, MED, HIGH	
TONE	LPF CUTOFF CONTROL	0% to 100%	
VIBRATO RATE	RATE OF VIBRATO	0.1Hz to 10Hz	
VIBRATO DEPTH	DEPTH OF VIBRATO	0% to 100%	
GAIN	GAIN STAGE OF THE PROCESSED SIGNAL	0% to 100%	
SYNC	SYNC ON OR OFF	ON, OFF	

**ENSEMBLE** (*Triple Tap Chorus; 120° phase shift*)

MIX	AMOUNT OF CHORUS SIGNAL IN THE OUTPUT	0% to 100%	CTRL 1
FEEDBACK	CHORUS SIGNAL FED BACK TO THE INPUT	0% to 100%	CTRL 2
TIME	CHORUS TIME	3ms to 60ms	
RATE	LFO RATE OF MODULATION	LOW, MED, HIGH	
DEPTH	LFO MODULATION DEPTH	0% to 100%	
TONE	LPF CUTOFF CONTROL	0% to 100%	
VIBRATO RATE	RATE OF VIBRATO	0.1Hz to 10Hz	
VIBRATO DEPTH	DEPTH OF VIBRATO	0% to 100%	
SPREAD	STEREO SPREAD	0% to 100%	
GAIN	GAIN STAGE OF THE PROCESSED SIGNAL	0% to 100%	
SYNC	SYNC ON OR OFF	ON, OFF	

**6 STAGE PHASER** *(Six All Pass Filter Stage Phaser (MF-103 Style))*

MIX	AMOUNT OF PHASER SIGNAL IN THE OUTPUT	0% to 100%	CTRL 1
FEEDBACK	PHASER FEEDBACK EMULATION	0% to 100%	
SWEEP	PHASER ZERO POINT	0% to 100%	
RATE	LFO RATE OF MODULATION	0.01Hz to 20Hz	CTRL 2
DEPTH	LFO DEPTH OF MODULATION	0% to 100%	
TONE	LPF CUTOFF ON MIXED SIGNAL, DAMPENS HIGH FREQUENCY INTENSITY	0% to 100%	
NOISE	NOISE AMOUNT	0% to 100%	
GAIN	GAIN STAGE OF THE PROCESSED SIGNAL	0% to 100%	
SYNC	SYNC ON OR OFF	ON, OFF	

**12 STAGE PHASER** *(Twelve All Pass Filter Stage Phaser (MF-103 Style))*

MIX	AMOUNT OF PHASER SIGNAL IN THE OUTPUT	0% to 100%	CTRL 1
FEEDBACK	PHASER FEEDBACK EMULATION	0% to 100%	
SWEEP	PHASER ZERO POINT	0% to 100%	
RATE	LFO RATE OF MODULATION	0.01Hz to 20Hz	CTRL 2
DEPTH	LFO DEPTH OF MODULATION	0% to 100%	
TONE	LPF CUTOFF ON MIXED SIGNAL, DAMPENS HIGH FREQUENCY INTENSITY	0% to 100%	
NOISE	NOISE AMOUNT	0% to 100%	
GAIN	GAIN STAGE OF THE PROCESSED SIGNAL	0% to 100%	
SYNC	SYNC ON OR OFF	ON, OFF	

**TIME PHASER** *(Four All Pass Filter Stage Phasers into a Single Tap Delay Line)*

MIX	AMOUNT OF PHASER SIGNAL IN THE OUTPUT	0% to 100%	CTRL 1
PHASER FEEDBACK	PHASER FEEDBACK EMULATION	0% to 100%	
SWEEP	PHASER ZERO POINT	0% to 100%	
RATE	LFO RATE OF MODULATION	0.01Hz to 20 Hz	
DEPTH	LFO DEPTH OF MODULATION	0% to 100%	
TONE	LPF CUTOFF ON MIXED SIGNAL, DAMPENS HIGH FREQUENCY INTENSITY	0% to 100%	
NOISE	NOISE AMOUNT	0% to 100%	
DELAY AT FEEDBACK	AMOUNT OF DELAY SIGNAL FED BACK TO THE INPUT	0% to 100%	
TIME	TIME OF DELAYED SIGNAL	0.1ms to 2000ms	CTRL 2
GAIN	GAIN STAGE OF THE PROCESSED SIGNAL	0% to 100%	
SYNC	SYNC ON OR OFF	ON, OFF	

**BIT CRUSHER** (*Crossover Filter for Dual Bit Crushing*)

MIX	AMOUNT OF EFFECT SIGNAL IN THE OUTPUT	0% to 100%	CTRL 1
DEPTH	BIT DEPTH	2-BIT to 24-BIT	CTRL 2
RATE	SAMPLE RATE	128Hz to 48kHz	
GAIN	GAIN STAGE OF THE PROCESSED SIGNAL	0% to 100%	

**RESONATOR** (*Resonant Filterbank*)

MIX	AMOUNT OF EFFECT SIGNAL IN THE OUTPUT	0% to 100%	CTRL 1
RESONANCE	RESONANCE FOR THE THREE FILTERS	0% to 100%	CTRL 2
CUTOFF LOW	CUTOFF/CENTER FREQUENCY OF FILTER 1 (DEFAULT VALUE = 500Hz)	10Hz to 22kHz	
CUTOFF MID	CUTOFF/CENTER FREQUENCY OF FILTER 2 (DEFAULT VALUE = 1kHz)	10Hz to 22kHz	
CUTOFF HIGH	CUTOFF/CENTER FREQUENCY OF FILTER 1 (DEFAULT VALUE = 5kHz)	10Hz to 22kHz	
LEVEL LOW	LEVEL OF FILTER 1	0% to 100%	
LEVEL MID	LEVEL OF FILTER 2	0% to 100%	
LEVEL HIGH	LEVEL OF FILTER 3	0% to 100%	
FILTER TYPE	RESPONSE TYPE OF THE THREE FILTERS	LP, BP, HP	
MOD RATE	RATE OF MODULATION	0.01Hz to 10Hz	
MOD DEPTH	DEPTH OF MODULATION	0% to 100%	
GAIN	GAIN STAGE OF THE PROCESSED SIGNAL	0% to 100%	

**10 BAND VOCODER** (*Vintage Style Ten-Band Vocoder*)

MIX	AMOUNT OF VOCODER SIGNAL IN THE OUTPUT	0% to 100%	CTRL 1
SIBILANCE	AMOUNT OF SIBILANCE SIGNAL MIXED INTO THE OUTPUT	0% to 100%	
SENSITIVITY	GATE SENSITIVITY CONTROL FOR THE MIC INPUT	0% to 100%	CTRL 2
TONE	HPF OF SIBILANCE NOISE/SIGNAL	0% to 100%	
NOISE	MIX BETWEEN INPUT SIBILANCE SIGNAL & HPF NOISE	0% to 100%	

**16 BAND VOCODER** (*Vintage Style Sixteen-Band Vocoder*)

MIX	AMOUNT OF VOCODER SIGNAL IN THE OUTPUT	0% to 100%	CTRL 1
SIBILANCE	AMOUNT OF SIBILANCE SIGNAL MIXED INTO THE OUTPUT	0% to 100%	
SENSITIVITY	GATE SENSITIVITY CONTROL FOR THE MIC INPUT	0% to 100%	CTRL 2
TONE	HPF OF SIBILANCE NOISE/SIGNAL	0% to 100%	
NOISE	MIX BETWEEN INPUT SIBILANCE SIGNAL & HPF NOISE.	0% to 100%	

**EVENTIDE® ROOM** (*Eventide parametric room reverb.*)

REFLECTION	DENSITY, SPREAD, AND TIME MACRO FOR EARLY REFLECTION DELAY TAP NETWORK	THIS EFFECT HAS 20 DETENTS AS FOLLOWS EARLY 10 + LATE 0 (0), EARLY 10 + LATE 1 (0.05), ....., EARLY 10 + LATE 10 (0.5), EARLY 9 + LATE 10 (0.55), ....., EARLY 0 + LATE 10 (1)
DIFFUSION	FEEDBACK COEFFICIENT FOR EARLY REFLECTION LOOP	0 - 100
MOD LEVEL	MODULATION DEPTH OF DELAY TAP IN EARLY REFLECTIONS	0 - 100
HIGH FREQ	CUTOFF FOR LPF PRESENT IN POST CROSSOVER REVERB TANKS	1000Hz - 5000Hz
HIGH LEVEL	GAIN COEFFICIENT POST HIGH ALL PASS RING TANK	-100-100
LOW LEVEL	GAIN COEFFICIENT POST LOW ALL PASS RING TANK	0 - 1
PRE DELAY	PRE DELAY TIME BEFORE THE REVERB TAIL BEGINS	0 - 500ms
SIZE	PERCEIVED SIZE OF THE REVERBERANT SPACE	0 - 100
DECAY	OVERALL DECAY FOR THE ENTIRE REVERB FEEDBACK PATH	0 - 100

**EVENTIDE® HALL** (*Master Hall Effect*)

LOW DECAY	GAIN COEFFICIENT IN LOW FREQUENCY ALL PASS TANK	0.1-5.0X (0.95), INFINITE, FREEZE(1)
HIGH DECAY	GAIN COEFFICIENT IN HIGH FREQUENCY ALL PASS TANK	0.1-5.0X (0.95), INFINITE, FREEZE(1)
MOD LEVEL	MODULATION DEPTH OF DELAY TAP IN EARLY REFLECTIONS	0 - 100
MID LEVEL	GAIN COEFFICIENT POST MID ALL PASS RING TANK	-100 - 100
HIGH LEVEL	GAIN COEFFICIENT POST HIGH ALL PASS RING TANK	-100 - 100
LOW LEVEL	GAIN COEFFICIENT POST LOW ALL PASS RING TANK	-100 - 100
PRE DELAY	PRE DELAY TIME BEFORE THE REVERB TAIL BEGINS	0ms - 1500ms
SIZE	PERCEIVED SIZE OF THE REVERBERANT SPACE	0 - 100
DECAY	OVERALL DECAY FOR THE ENTIRE REVERB FEEDBACK PATH	0.0s - 20s(0.85), INFINITE, FREEZE(1)

**EVENTIDE® PLATE** (*Master Plate Effect*)

DISTANCE	DELAY TIME FOR EARLY REFLECTION TAP NETWORK	0 - 100
DIFFUSION	FEEDBACK COEFFICIENT FOR EARLY REFLECTION NETWORK	0 - 100
MOD LEVEL	MODULATION DEPTH OF DELAY TAP IN EARLY REFLECTIONS	0 - 100
TONE	CUTOFF FOR LPF AT INPUT	-100 - 100
HIGH DAMP	GAIN COEFFICIENT INSIDE HIGH ALL PASS RING TANK	100 - 0
LOW DAMP	GAIN COEFFICIENT INSIDE LOW ALL PASS RING TANK	100 - 0
PRE DELAY	PRE DELAY TIME BEFORE THE REVERB TAIL BEGINS	0ms-1500ms
SIZE	PERCEIVED SIZE OF THE REVERBERANT SPACE	0 - 100
DECAY	OVERALL DECAY FOR THE ENTIRE REVERB FEEDBACK PATH	0.25S - 10s(0.85), INFINITE, FREEZE(1)

**EVENTIDE® SHIMMER** (*Master Shimmer Effect*)

A PITCH	PITCHED CONTENT IN THE REVERBERANT OUTPUT	-2410C - +2410
B PITCH	PITCHED CONTENT IN THE REVERBERANT OUTPUT	-2410C - +2410
PITCH DECAY	DECAY TIME OF THE PITCHED CONTENT IN THE REVERB TAIL	0-100%(0.85), PITCH FREEZE, PITCH+REVERB FREEZE(1)
MID DECAY	DECAY TIME OF THE MID FREQUENCY CONTENT IN THE REVERB TAIL	0 - 100
LOW DECAY	DECAY TIME OF THE LOW FREQUENCY CONTENT IN THE REVERB TAIL	0 - 100
HIGH DECAY	DECAY TIME OF THE HIGH FREQUENCY CONTENT IN THE REVERB TAIL	0 - 100
DELAY	PRE DELAY TIME BEFORE THE REVERB TAIL BEGINS	50ms - 1000ms
SIZE	PERCEIVED SIZE OF THE REVERBERANT SPACE	0 - 100
DECAY	OVERALL DECAY FOR THE ENTIRE REVERB FEEDBACK PATH	0 - 100

**EVENTIDE® BLACKHOLE** (*Master Blackhole Effect*)

<b>PARAMETER NAME</b>	<b>PARAMETER DESCRIPTION</b>	<b>RANGE</b>
MOD DEPTH	MODULATION DEPTH FOR EARLY REFLECTION STAGE	0 - 100
MOD RATE	MOD RATE FOR EARLY REFLECTION STAGE	0 - 100
FEEDBACK	FEEDBACK SIGNAL FOR EARLY REFLECTIONS	0-100 (0.9), INFINITE, FREEZE(1)
RESONANCE	RESONANCE PEAKS IN RESONANT BIQUAD CROSSOVER	0 - 100
HIGH LEVEL	GAIN COEFFICIENT POST HIGH ALL PASS RING TANK	-100 - 100
LOW LEVEL	GAIN COEFFICIENT POST LOW ALL PASS RING TANK	-100 - 100
PRE DELAY	PRE DELAY TIME BEFORE THE REVER TAIL BEGINS	0 - 2000ms
SIZE	PERCEIVED SIZE OF THE REVERBERANT SPACE	0 - 100
GRAVITY	SOME SORT OF BLOOM OR GAIN FEEDBACK COEFFICIENT	-100 - 100



*This page left intentionally blank*

## LEFT HAND CONTROLLER FUNCTIONS

The Left Hand Controller panel contains a variety of dynamic, hands-on features that can bring higher levels of expression and articulation to any Moog One performance. The scope of these controllers can be tailored to the performer's taste - or to a particular sound and song - using the MORE page parameters. These settings can be saved separately with each Synth.

**NOTE:** Assigning the **MOD** wheel and **X/Y PAD** to specific modulation parameters can be done using the Expression Assign buttons or the Modulation Matrix. The **X/Y PAD** Pressure modulation parameter can only be assigned using the Modulation Matrix.

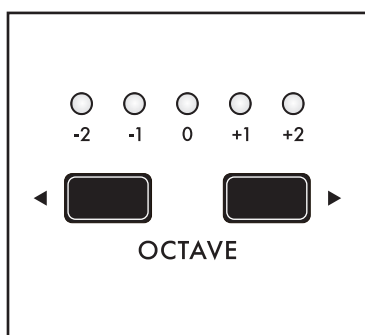

### OCTAVE SHIFT (-2 to +2)

The ◀**OCTAVE** and **OCTAVE**▶ buttons shift the keyboard relationship to musical pitch, in octave units. For example, by shifting down two octaves, the C key in the middle of the keyboard will now play the note C3 (MIDI Note #48), where the same key at the default octave setting previously played C5 (MIDI Note #72). This ability to Octave Shift matches the playing area to the performance, without the need to reprogram the sound and Oscillator settings.

**NOTE:** Press and hold both **OCTAVE** buttons to send a MIDI Panic (All Notes and Controllers Off) message.

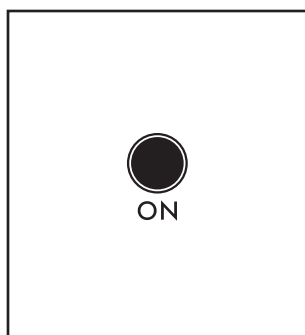

### GLIDE (ON/LIT, OFF/UNLIT)

Instead of stepping or jumping from one note to the next, Glide (also known as portamento) delivers a smooth, continuous change in pitch when moving from one note to another. This button toggles the Glide effect On (lit) and Off (unlit). Depending on the Glide Type parameter selected in the LHC MORE page and the value of the **GLIDE RATE** knob set on this panel, the glide can be a dramatic effect, a quick ornament to the note, or anything in between.

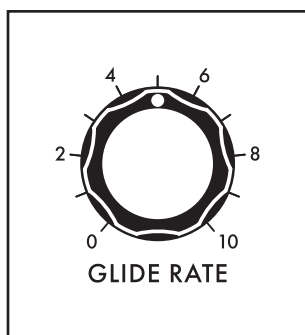

### GLIDE RATE (0 to 10)

Although the Glide Rate is set using this knob, the rate is also determined by the Glide parameters found in the LHC MORE page. The range of values is 0 ms to 10 sec.

## LEFT HAND CONTROLLER FUNCTIONS *(Continued)*

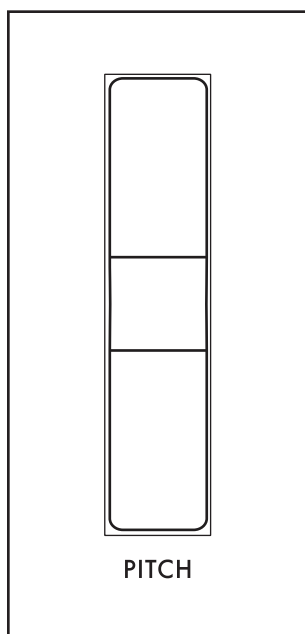

### **PITCH WHEEL**

The spring-loaded **PITCH** wheel can bend the musical pitch up or down by an assignable number of semitones for each direction (UP or DOWN) of the wheel's travel. Set using parameters found on the LHC MORE page, these values are added to the BEND UP OFFSET and BEND DOWN OFFSET parameters found in the individual Oscillator MORE pages, allowing for exacting control.

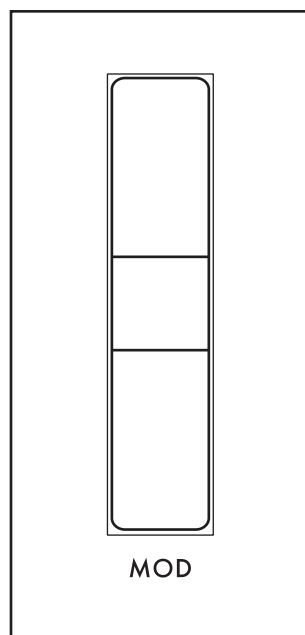

### **MOD WHEEL**

Use the **MOD** wheel to manually articulate the amount of modulation being applied - in one or multiple instances. Unlike the **PITCH** wheel, the **MOD** wheel is not spring-loaded, and its starting position can be saved as part of the Preset.

**NOTE:** *Moog One is equipped with an aluminum **MOD** wheel that has been purposefully designed to move with a bit more resistance than a typical modulation wheels. This allow the **MOD** wheel to be set and left at a precise placement.*

## LEFT HAND CONTROLLER FUNCTIONS *(Continued)*

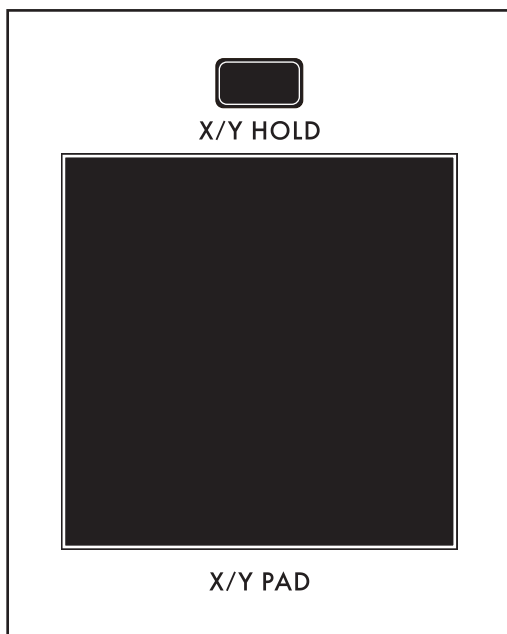

### **X/Y PAD**

Sliding a finger across the **X/Y PAD** controls two individual parameters at the same time, in different amounts. One is assigned to the X axis, the second to the Y axis. There is also a third axis that can sense pressure on the pad. Also, anytime the pad is touched, a gate signal is created that can be used as a Modulation Matrix source/controller or as a CV Out source. The current X and Y values can be frozen using the **X/Y HOLD** button. This held value can be saved as part of the Preset, similar to the **MOD** wheel amount.



### **HEADPHONES**

Moog One provides two 1/4" stereo headphones jacks, located on the front edge of the LHC panel, allowing you and a friend to both listen to Moog One without any external amplifiers.

### **LHC MORE PAGE**

Pressing the triangular **MORE** button in the upper right corner of the Left Hand Controller will reveal a second level of parameters that can be accessed and modified using the interactive portion of the Center Console. These additional parameters are displayed in the bottom portion of the screen. The left pane shows a representation of the **X/Y PAD** surface. The red dot indicates the current position of the finger on the pad, or the last held position if **X/Y HOLD** is On. The size of the dot image will change as more pressure is applied to the **X/Y PAD**. The right pane shows the current value of the Front Panel hardware parameters for this module. Tweaking these panel controls will update their values here.

**NOTE:** Pressing the (now) illuminated **MORE** button will exit the **MORE** page and recall the **HOME** screen.

## LEFT HAND CONTROLLER FUNCTIONS *(Continued)*

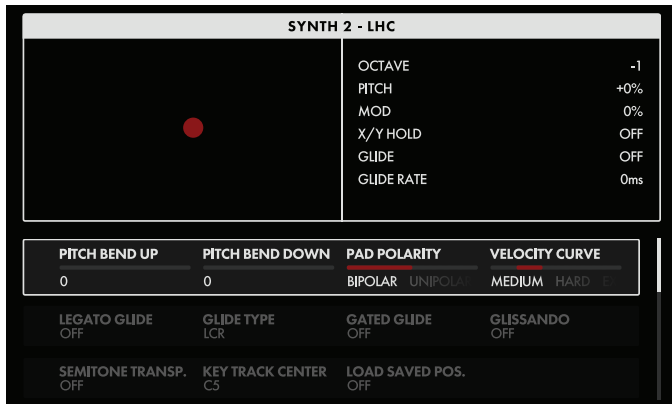

The onscreen MORE page parameters are edited using the four Soft Knobs below the screen.

### CHANGING THE VALUE

Rotate the Soft Knob below the parameter name to change its value. In some cases, the Soft Knob simply turns a function on or off. In other cases, the Soft Knob may choose from a list of values or settings, and in other cases, the Soft Knob is dialing in a value – either absolute or a percentage.

### SELECTING A ROW

The scroll bar at the right edge indicates the current row. Rotate the Master Encoder to the right to highlight the next row of parameters. Rotating the Master Encoder to the left will select a previous row. Again, rotate the Soft Knob below the parameter to change its value.

### PITCH BEND UP *(-24 to 0 to +24)*

The change in pitch caused by moving the **PITCH** wheel up can be specified here. Negative values will cause the pitch to lower, and positive values will cause the pitch to rise. The range is four octaves – two octaves up, and two octaves down in semitone units. With a value of zero, the **PITCH** wheel will have no effect when moved up.

**NOTE:** Holding the **SHIFT** button while operating the Pitch Bend Up Soft Knob will allow a finer resolution than semitone units when setting the value.

### PITCH BEND DOWN *(-24 to 0 to +24)*

The change in pitch caused by moving the **PITCH** wheel down can be specified here. Negative values will cause the pitch to lower, and positive values will cause the pitch to rise. The range is four octaves – two octaves up, and two octaves down in semitone units. With a value of zero, the **PITCH** wheel has no effect when moved down.

**NOTE:** Holding the **SHIFT** button while operating the Pitch Bend Down Soft Knob will allow a finer resolution than semitone units when setting the value.

### PAD POLARITY *(UNIPOLAR, BIPOLAR)*

The polarity setting for the **X/Y PAD** can be set here, using the Soft Knob.

#### UNIPOLAR

Unipolar operation places the zero location of the pad in the lower left corner, providing positive values along the X and Y axes.

#### BIPOLAR

Bipolar mode places the zero location in the center of the pad, providing access to positive and negative values along both axes.

## LEFT HAND CONTROLLER FUNCTIONS *(Continued)*

### **VELOCITY CURVE** *(SOFT, MEDIUM, HARD, COMPRESS, EXPAND)*

By providing selectable curves to interpret how the keys are played, Moog One can provide a better measure of playing technique and velocity response.

**NOTE:** *There are situations where you may wish to apply a different Velocity curve to two different Synths, even if you are playing the same keys inside a single Preset. For example, setting one Synth to follow the Compress curve and a second to follow the Expand curve will provide a dynamic way to change the mix of the sounds live, solely using velocity.*

#### **SOFT**

Players with a softer touch will be able to produce louder (higher velocity) notes without as much effort.

#### **MEDIUM**

This is the default velocity curve, and is appropriate for most players.

#### **HARD**

Players with a heavier touch will find it easier to produce softer (lower velocity) notes without restraining their playing style.

#### **COMPRESS**

This option “reigns in” the dynamic extremes of the performer, producing a more constant level. This can be useful for players who sometimes play notes so softly they are not heard, and so loudly they become overpowering.

#### **EXPAND**

The opposite of Compress, the Expand curve can make loud notes a touch louder, and soft notes a touch softer, providing a broader dynamic range than would otherwise be achieved.

### **GATED GLIDE** *(OFF, ON)*

This is a special case for using Glide. When On, the keyboard acts as a gate that will pause and resume the glide effect as the key(s) is played.

### **LEGATO GLIDE** *(OFF, ON)*

Again, a special case for articulating the Glide effect. In this case, Glide is produced only when the notes are played legato-style (one is held down as the new note plays). If the notes are played in a non-legato, or staccato fashion (the previous note is released before the new note is played), the Glide effect will not be produced.

**NOTE:** *LEGATO GLIDE only is only available if the active Synth is in the MONO Mode.*

### **GLIDE TYPE** *(LCR, LCT, EXP)*

Three distinct types of Glide are provided, and each one handles the timing of gliding from Note A to Note B a bit differently.

#### **LCR (LINEAR CONSTANT RATE)**

In this mode, the Rate is constant, so gliding further takes longer. If the glide takes a specific amount of time to go one octave, it will take twice that amount of time to glide two octaves.

#### **LCT (LINEAR CONSTANT TIME)**

In this mode, the Time is constant, regardless of the distance traveled. Gliding to a note one octave away will take exactly the same amount of time as gliding to a note two octaves away.

#### **EXP (EXPONENTIAL)**

In this mode, the Rate changes over an exponential curve, slowing as the target note is approached.

## LEFT HAND CONTROLLER FUNCTIONS *(Continued)*

### **GLISSANDO** *(OFF, ON)*

As an alternative to the smooth continuous change provided by Glide, there is Glissando. When the GLISSANDO parameter is set to On, the transition from one note to another will move through all of the intervening notes in a stepped, staircase fashion. It is the equivalent of sliding your finger down a fretted bass neck (Glissando) as opposed to a fretless bass (Glide).

### **LOAD SAVED POS.** *(OFF, MOD WHEEL, PAD, BOTH)*

The position of the **MOD** wheel and the held position on the **X/Y PAD** can be saved as part of the active Synth. This parameter determines whether those held values are saved and loaded the next time the Synth is recalled.

#### **OFF**

Neither the **MOD** wheel position nor the held **X/Y PAD** position is saved as part of the Synth.

#### **MOD WHEEL**

The position of the **MOD** wheel is saved and reloaded as part of the Synth.

#### **PAD**

The held position of the **X/Y PAD** is saved and reloaded as part of the Synth.

#### **BOTH**

The position of the **MOD** wheel and the held position of the **X/Y PAD** are both saved and reloaded as part of the Synth.

### **SEMITONE TRANSP.** *(-12 to OFF to +12)*

The overall pitch of the active Synth may be transposed up or down up to one octave, in semitone units. Layered Synths can be pitched a fifth or an octave apart; songs can be played in new keys using established fingering; and you can adjust your key to match another vocalist or performer. The default position is OFF.

### **KEY TRACK CENTER** *(C0 to G10)*

All of the Moog One Keyboard Tracking (KB TRACK.) parameters default to using Middle C (MIDI Note #60) as the center note. This is the note from which positive KB TRACK values begin, and the point from which negative KB TRACK values start. The center note itself is unaffected by these parameters; it merely serves as a starting point. This center note can be re-assigned to any MIDI Note, from C0 (MIDI Note #1) to G10 (MIDI Note #127).

## THE BROWSER

Presets and Timbres are loaded from memory via the Browser. Before opening the Browser, note that the HOME screen shows the name of the current Preset, plus the names of the individual Timbre(s) that comprise that Preset. Remember that each Preset can contain up to three individual Synths. If the Preset is assigned to the current Performance Set, the SET, BANK, and PRESET fields will show its location.

**NOTE:** Sequences, Effect Settings, and Modulation Matrices are saved and loaded from their respective MORE pages. The Browser and the SAVE button functions are only applicable to Presets and Synths.

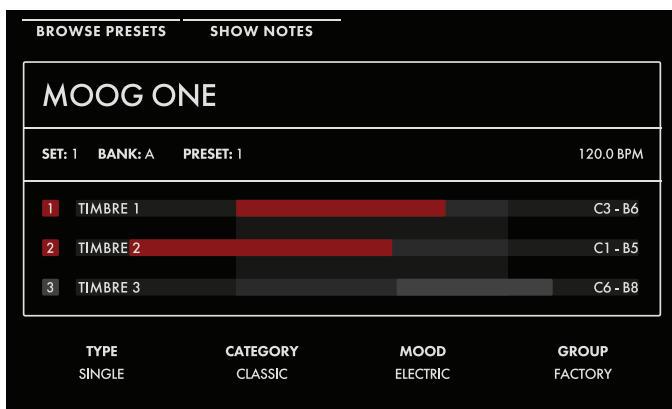

### TAGS

Along the bottom edge of the HOME screen are the Tags assigned to the current Preset, in terms of TYPE, CATEGORY, MOOD, and GROUP. These tags make it easy to search for Presets by narrowing the list. While all of the tag types come with some preloaded suggestions, the user is free to create their own CATEGORY, MOOD, and GROUP divisions. Only TYPE has fixed options - SINGLE, LAYER, SPLIT, and MULTI. Generally, one would use SINGLE for a Preset using a single Synth. SPLIT for multiple Synths playing in different areas

of the keyboard, LAYER for multiple Synths stacked on the same keys, and MULTI for a Preset combining SPLITS and LAYERS, etc.

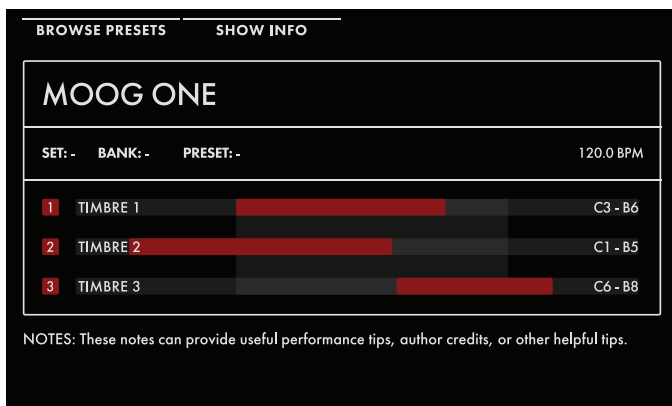

### NOTES

Pressing the SHOW NOTES Soft Button at the top of the HOME screen will replace the Tag information with any performance notes that were saved with the Preset. These notes can be anything that may be of value to the player/performer, from a reminder about changing keys for the bridge or singing backups on the chorus, to starting on the pickup count of three. To return to the previous (Tag) screen, just press the SHOW INFO Soft Button.



## USING THE BROWSER

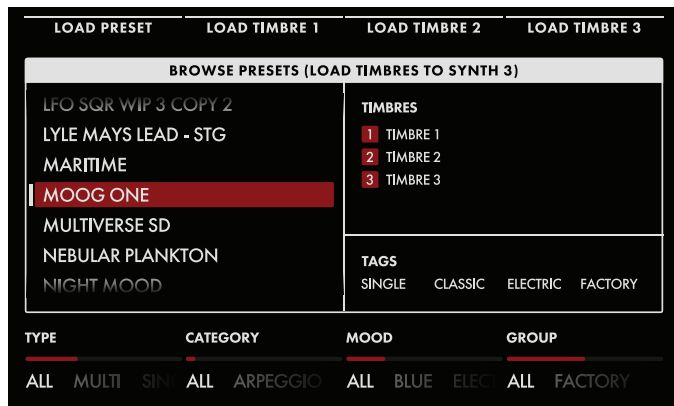

Press the BROWSE PRESETS Soft Button at the top of the HOME screen to open the Browser. Every Preset must have a unique name in order to be saved, but the same Synth (or a Synth using the same name) can be saved within multiple Presets. The Browser lets you look within every Preset to see the individual Synth Timbres that they contain, so that you can load individual Timbres from any Preset into any active Synth.

*Tip: You can also access the Browser by pressing the **HOME** button when on the home page (or, effectively, by double-pressing the **HOME** button at any time).*

### LOADING A PRESET

The left pane shows a list of all the Presets that match the search criteria set by the four Soft Knobs at the bottom of the screen. Selecting a specific TYPE, CATEGORY, MOOD, and/or GROUP will reveal only the Presets that were saved with those Tags, generating a much shorter list and making it easy to find a suitable Preset. The ALL value is effectively the Off switch for that criteria, removing it from the search equation. The upper right pane lists the individual Synth Timbres that make up the highlighted Preset. The lower right pane displays the Tags information that was saved with the Preset.

Use the Master Encoder to scroll through the list of Presets in the left pane. Press the LOAD PRESET Soft Button at the top of the screen to load the selected and highlighted Preset.

***TIP:** When the PRESET AUTOLOAD function [SETTINGS / GLOBAL / HARDWARE SETTINGS] is set to On, scrolling from one entry to the next in the Browser will load the selected Preset automatically, without the need to Press down on the Master Encoder or to use the LOAD PRESET Soft Button.*

***TIP:** Loading a Preset will load up to three Synths, plus their respective Sequences (if any), their individual Modulation Matrices, their independent Arpeggiator settings, Synth Effect and Master Effect Settings, plus a held **MOD** Wheel value, a held **X/Y PAD** position, etc. In this regard, the Preset is a self-contained musical environment, created to perform a certain song, suite, or section perfectly.*

### LOADING A TIMBRE

A Timbre is defined as all of the parameters, collectively, that are attributed to a specific Synth in any given Preset. In this sense, it is the Timbre that defines the Synth. When the Browser is open, selecting and highlighting a Preset will reveal - in the upper right pane - the Timbres that were saved with that Preset. Any of those Timbres can also be loaded to the active Synth in the current Preset. Once you have selected and highlighted the Preset that contains the Timbre you're seeking, press one of the Load Timbre Soft Buttons at the top of the screen (LOAD TIMBRE 1, LOAD TIMBRE 2, LOAD TIMBRE 3) to load that Timbre to the active Synth (as chosen by the **KEYBOARD FOCUS** button on the Front Panel) in the current Preset.

## USING THE BROWSER *(Continued)*

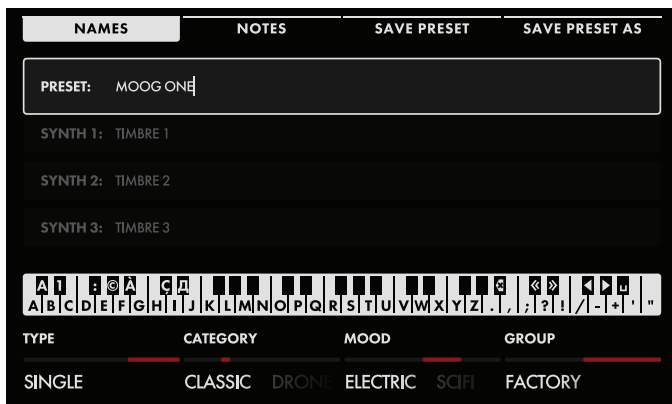

### SAVING PRESETS AND TIMBRES

Presets and Timbres are saved to memory using the **SAVE** button on the Front Panel. Pressing the **SAVE** button will reveal the Preset Save screen. The four Soft Buttons across the top of the screen will read NAMES, NOTES, SAVE PRESET, AND SAVE PRESET AS. When the screen opens, the NAMES Soft Button will already be selected, and the Preset Name will be highlighted.

### SAVE PRESET

If you have edited an existing Preset, and wish to save it under the same name, press the SAVE PRESET Soft Button at the top of the screen. You can also press the **SAVE** button on the Front Panel to save the Preset.

### SAVE PRESET AS

Moog One allows you to enter names and text directly from the keyboard. The white keys (naturals) enter the characters; the black keys (accidentals) select the character set (C#1 - D#2), move the cursor (F#5, G#5), delete a character (A#4), and add a space (A#5). Hold the (A#4) key to delete multiple characters. The Decrement and Increment keys (C#5 and D#5, respectively) can correct the letter/character immediately preceding the cursor to the previous or next symbol in the current character set, changing an M to an L or an N, for example with a single key press.

**NOTE:** The note numbers given above relate to the onscreen keyboard, and do not reflect the key's actual MIDI Note number, etc.

**TIP:** You can also enter text directly, using a standard USB keyboard connected to the Moog One's **USB HOST** port.

When you are done, press the SAVE PRESET AS Soft Button at the top of the screen. Preset names must be unique; if the name you have entered is already in use, a popup box will ask if you want to overwrite the Preset of the same name. Press the YES Soft Button to overwrite the existing Preset; press the **NO** Soft Button to return to previous screen and edit the name. Then you can press the SAVE AS Soft Button again and save the Preset under the new name.

### ADDING TAGS

Along the bottom edge of the SAVE screen are the Soft Knobs allowing you to assign TYPE, CATEGORY, MOOD, and GROUP Tags to the Preset, making it more discoverable in a search. Rotate the Soft Knobs to select a value for each search criteria. While all of the criteria come with some preloaded suggestions, each performer is free to create their own CATEGORY, MOOD, and GROUP divisions. Only TYPE has fixed options - SINGLE, LAYER, SPLIT, and MULTI. Generally, one would use SINGLE for a Preset using a single Synth. SPLIT for multiple Synths playing in different areas of the keyboard, LAYER for multiple Synths stacked on the same keys, and MULTI for a Preset combining SPLITS and LAYERS, etc.

### ADDING NOTES

In addition to naming/renaming and adding Tags, you can also add performance notes to be saved along with your Preset. These notes can be quick reminders or application cues, such as "Use this version for all live shows" or "Pan wide for the stereo Master Effect" etc. Press the NOTES Soft Button and enter any notes into the popup box using the ENTERING TEXT methods from the previous step. When you are done entering notes, use the SAVE or SAVE AS... Soft Buttons to save these notes with the current Preset; or press the NAMES Soft Button to close the notes box and return to the NAMES screen.

## USING THE BROWSER *(Continued)*

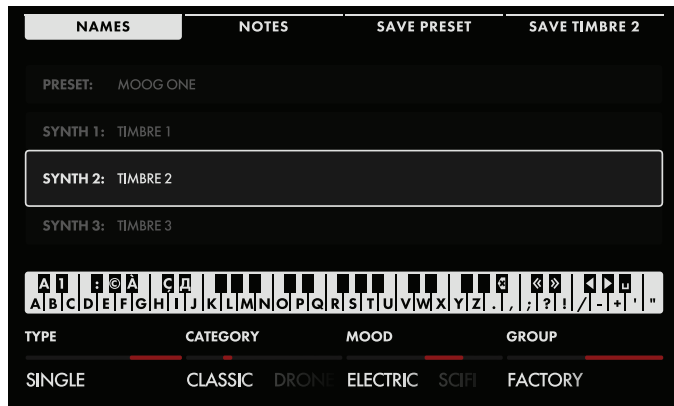

### SAVING TIMBRES

From the SAVE / NAMES screen, you can rotate the Master Encoder and highlight any Timbre contained in the current Preset. The selected Timbre can be given a new name using the same naming method defined in the SAVE AS section above, and then saved with the current Preset under this new name by pressing the SAVE PRESET Soft Button at the top of the screen. If you want to save the selected Synth individually, you can give it a new name and press the SAVE TIMBRE (X) Soft Button (where X= the selected Synth

Timbre). This will save the selected Timbre to a new Preset, which will contain only this Timbre, loaded in the Synth 1 slot of the new Preset.

### ADDING TAGS

Along the bottom edge of the SAVE screen are the Soft Knobs allowing you to assign TYPE, CATEGORY, MOOD, and GROUP Tags to the Timbre, making it more discoverable in a search. Rotate the Soft Knobs to select a value for each search criteria. While all of the criteria come with some preloaded suggestions, each performer is free to create their own CATEGORY, MOOD, and GROUP divisions. Only TYPE has fixed options - SINGLE, LAYER, SPLIT, and MULTI. Generally, individual Timbres default to Single. When the tags have been added, use the SAVE TIMBRE (X) Soft Button to save these Tags with the current Timbre/Preset.

### ADDING NOTES

In addition to naming/renaming and adding Tags, you can also add performance notes to be saved along with your TIMBRE. These notes can be quick reminders or application cues, such as “Use this version for all live shows” or “Pan wide for the stereo Master Effect” etc. Press the NOTES Soft Button and enter any notes into the popup box using the ENTERING TEXT methods from the previous step. When you are done entering notes, use the SAVE TIMBRE (X) Soft Button to save these notes with the current TIMBRE; or press the NAMES Soft Button to close the notes box and return to the NAMES screen.

## EDITING AND SAVING

When creating sounds and delving deep into the world of analog synthesis and creative sound design, few things are as important as saving your edits before they are lost forever. Fortunately, Moog One is equipped with a number of thoughtful features to ensure your critical work is easy to manage. For starters, as soon as any knob, button, or parameter is changed after you call up a Preset, the **SAVE** button on the Front Panel will dimly light as a reminder that there are unsaved changes present.

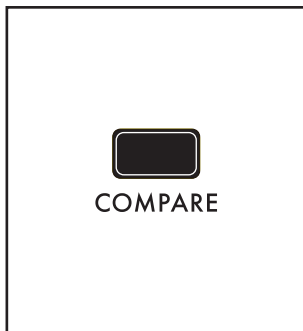

### COMPARE

When refining and editing a Preset, comparing it to the original (saved) version can help you decide if you are improving the sound or creating something totally different. The **COMPARE** button allows you to do just that, setting the original (saved) version is a separate buffer, so that you can compare your edits without reloading the original and losing your progress, or without continually saving, reloading, and comparing. Once a Preset has been loaded, and after you tweak your first parameter, press the **COMPARE** button on the Front Panel. The **COMPARE** button will light, and you can hear the original (Saved) version. Press the **COMPARE** button a second time (the button will go dark) and you can continue editing. At any time, pressing the **COMPARE** button so that it is lit will allow to hear the original version. Loading a different Preset will clear both the Edit and Compare buffers.

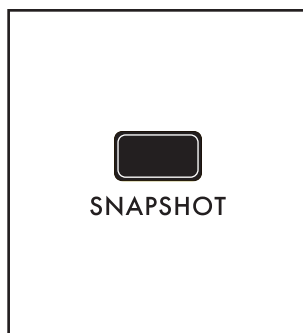

### SNAPSHOT

As you are editing, Moog One enables multiple Snapshots to be taken. Each Snapshot is a micro-save of the current Preset. In this way, you can save your edits as you go along, without having to worry about an all or nothing scenario when it comes to saving or losing your Preset edits. Press the **SNAPSHOT** button at any time to save a Snapshot. The current edited status of the Preset will be saved as a Snapshot.

To view the Snapshots saved with the current Preset, hold the **SHIFT** + **SNAPSHOT** buttons on the Front Panel to open the BROWSE SNAPSHOTS screen.

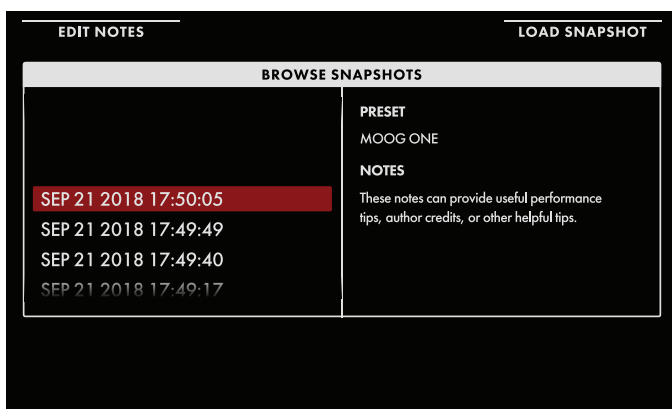

Each snapshot has been timestamped using the internal clock/calendar. The left pane shows the Snapshot list presented in chronological order, with the newest Snapshots at the top of the list. Using the Master Encoder, scroll the list of Snapshots. Press the LOAD SNAPSHOT Soft Button at the top of the screen to recall the selected snapshot. The right pane displays any performance notes that have been entered and saved with the selected Snapshot. To edit or enter these notes, press the EDIT NOTES Soft Button at the top of the screen. The NOTES

screen will open and you can enter text directly from the keyboard. Press the OK Soft Button at the top of the screen when you are done, or press the CANCEL Soft Button to exit.

## EDITING AND SAVING *(Continued)*

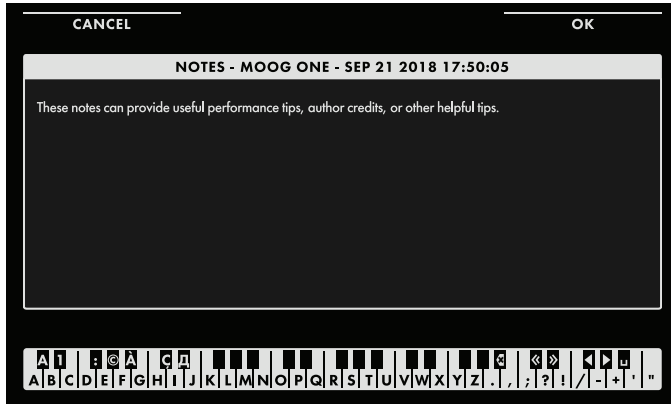

### ENTERING TEXT

Moog One allows you to enter names and text directly from the keyboard. The white keys (naturals) enter the characters; certain black keys (accidentals) have specific functions.

- Keys C#1 - D#2 select the character set.
  - Key F#4 removes the current name and randomly generates a new name.
  - Key G#4 clears all the characters in the screen.
  - Key A#4 deletes the character to the left of the cursor.
- Keys C#5 and D#5, respectively, change the character immediately preceding the cursor to the previous or next symbol in the current character set, changing an M to an L or an N, for example with a single key press.
  - Keys F#5 and G#5 move the cursor left or right, respectively.
  - Key A#5 adds a space.

**NOTE:** The note numbers given above relate to the onscreen keyboard, and do not reflect the key's actual MIDI Note number, etc.

**TIP:** Notes can be added to any highlighted Snapshot in the list, regardless of whether you choose to load it into memory using the LOAD SNAPSHOT Soft Button or not.

**TIP:** You can also enter text directly, using a standard USB keyboard connected to the Moog One **USB HOST** port.

Once you have loaded a Snapshot, you can use the SAVE menu SAVE PRESET Soft Button operation to overwrite the Preset using this version. Any performance notes saved to that Snapshot will now be saved with the Preset, and all the other Snapshots will remain in the Snapshot file. Or you can choose to save the recalled Snapshot as its own separate Preset, by assigning it a new name and using the the SAVE PRESET AS. Soft Button command. When creating a new Preset in this manner, no Snapshots are saved with the new Preset. Individual Snapshots may be highlighted using the Master Encoder, and then removed from memory using the **DELETE** button on the Front Panel.

### AUTOSAVE

The Autosave function is a special type of Snapshot. Basically, Moog One automatically saves a Snapshot of any unsaved edits you have performed on a Preset, either when you switch Presets or make other large changes such as loading new Sequences, Effect or Mod Matrix presets, etc. When you open the Snapshot file by pressing the **SHIFT + SNAPSHOT** buttons, one of the snapshots in the list will carry the marker (AUTOSAVE). This Snapshot is a record of your unsaved changes from the last time you visited this Preset. You can load and save this Autosave file as you would any other Snapshot.

# SETTINGS

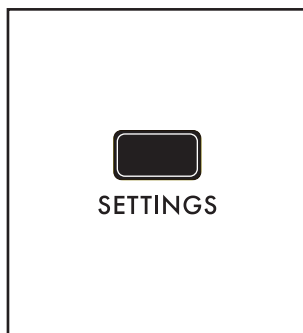

## SETTINGS

Pressing the **SETTINGS** button opens the door to a host of under-the-hood functions that control Moog One global parameters, configure hardware controls and connections, manage libraries, and administer firmware updates.

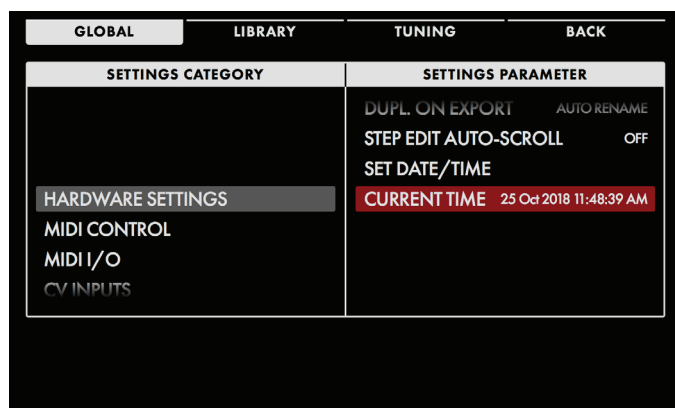

Three Soft Buttons at the top of the screen open the GLOBAL, LIBRARY, and TUNING pages, respectively. The left pane shows the Settings Category; the right pane shows the individual parameters of that category. Rotating the Master Encoder will select and highlight an item from the list shown in the left pane. Pressing down on the Master Encoder will move the red-colored cursor to the right pane, where an individual parameter may be selected and highlighted by rotating the Master Encoder. The Settings Category will remain highlighted in gray.

Values for the specific parameter selected in this right pane are controlled using the Soft Knobs(s) at the bottom of the screen.

**TIP:** When the cursor is located on the right pane, pressing down on the Master Encoder will launch an action or enter a sub-menu for the selected item, if available. To move the cursor back from the right to the left pane, press the BACK Soft Button.

## GLOBAL

The Settings screen opens to the Global page. If the Global page is not selected, press the GLOBAL Soft Button at the top of the screen.

*This page left intentionally blank*

## HARDWARE SETTINGS

These parameters specify how the panel hardware behaves, the intensity of the LEDs, and other factors relating to interaction with your Moog One.

### **KNOB MODE** (*ABSOLUTE, PASS THROUGH, RELATIVE*)

Having hardware knobs on a programmable synthesizer means that once a new Preset is loaded, a knob will no longer reflect the current value of that parameter. Knob Mode determines how a knob should respond when it is tweaked.

#### **ABSOLUTE**

In this mode, the parameter value will immediately jump to match the current position of the hardware knob.

#### **PASS THROUGH**

In this mode, the parameter value will remain unchanged as the knob is turned, until the knob position matches the current value. So, in this case, the knob must pass through the current setting before it becomes active. From then on, the knob will function normally.

#### **RELATIVE**

In this mode, the value range is scaled so that the current value is matched to the actual knob position, and the remaining knob range equals the distance from the saved value to the minimum or maximum extreme. The minimum and maximum values remain the same, and once the knob has been turned to the end of its physical range, it will function normally.

### **CHORD MEMORY** (*SILENT LEARN, AUDIBLE LEARN*)

Entering notes into the CHORD Memory note stack using the **LEARN** button can be done audibly, so you can hear the notes as they are entered, or silently so that the audience doesn't hear you loading the chord in a performance situation

#### **SILENT LEARN**

In this mode, the output of the active Synth is muted while the **LEARN** button is engaged, allowing the chord to be learned discreetly.

#### **AUDIBLE LEARN**

In this mode, the output of the active Synth is unaffected by the **LEARN** button.

### **LCD BRIGHTNESS** (*0% to 100%*)

The brightness of the LCD panel in the Center Console is controlled by this parameter.

### **PANEL LED BRIGHTNESS** (*0% to 100%*)

This one parameter proportionally controls the brightness of every LED on the Front Panel.

### **SHOW BANK PREVIEW** (*OFF, ON*)

When the Show Bank Preview parameter is set to On, selecting a BANK button (**A - H**) from the Performance Set area will open a preview screen showing the Names and locations of all the Presets assigned to that Bank. The preview screen will not appear when the Show Bank Preview parameter is Off.

### **PRESET AUTOLOAD** (*OFF, ON*)

When Autoload is set to On, scrolling through a list of saved Presets, Synths, Sequences, Modulation Matrices, or Effects, etc. will immediately load the next highlighted item as you rotate the Master Encoder; there is no need to press down on the Master Encoder or select the LOAD Soft Button from the top of the screen to finish loading the selected item. This can be useful to quickly load sounds arranged in order, but may be a hindrance when just reviewing the list. In this case, keep the Autoload parameter set to Off.



## **HARDWARE SETTINGS** *(Continued)*

### **DUPLICATE NAMES ON IMPORT** *(IGNORE, OVERWRITE, AUTO RENAME, MANUAL RENAME)*

This parameter lets you tell Moog One how to proceed when importing an item from a USB memory device in the case when there is already a similar item in memory using the same name.

#### **IGNORE**

When this value is selected, items with identical names will not be imported.

#### **OVERWRITE**

When this value is selected, the imported item will replace the item of the same name in memory by rewriting the data.

#### **AUTO RENAME**

When this value is selected, the imported item will be given a new name by adding COPY 1 to the end of the name, and then saved to memory. If COPY 1 has already been used, COPY 2 will be added, etc.

#### **MANUAL RENAME**

When this value is selected, a popup screen will inform you that this name is already in use, and prompt to you to provide a new name. Enter the new name and press the OK Soft Button to import the item under the new name, or press the SKIP Soft Button to cancel.

### **DUPLICATE NAMES ON EXPORT** *(IGNORE, OVERWRITE, AUTO RENAME, MANUAL RENAME)*

This parameter lets you tell Moog One how to proceed when exporting an item to a USB memory device or another User Space when there is already a similar item stored that is using the same name.

#### **IGNORE**

When this value is selected, items with identical names will not be exported.

#### **OVERWRITE**

When this value is selected, the item being exported will replace the item of the same name by rewriting the data.

#### **AUTO RENAME**

When this value is selected, the exported item will be given a new name by adding a COPY 1 to the end of the name, and then saved to the external device. If COPY 1 has already been used, COPY 2 will be added, etc.

#### **MANUAL RENAME**

When this value is selected, a popup screen will inform you that this name is already in use, and prompt to you to provide a new name. Enter the new name and press the OK Soft Button to export the item under the new name, or press the SKIP Soft Button to cancel.

### **STEP EDIT AUTO-SCROLL** *(OFF, ON)*

When this parameter is set to On, the STEP EDIT screen will automatically scroll from page to page as the Sequence plays. When this parameter is off, the STEP EDIT screen will stay on the selected page of the Sequence as it plays.

### **NOISE REDUCTION** *(-24 dB to 0 dB)*

An internal Noise Reduction routine dynamically reduces the per-voice amount of apparent background noise when Moog One is not playing – in between notes, etc. The amount of Noise Reduction can be specified in decibel amounts. The default value is -12 dB. Rotating the Soft Knob to the left can increase the Noise Reduction level to -24 dB; rotating the Soft Knob to the right can decrease the Noise Reduction level to 0 dB, where no Noise Reduction is being applied.

## HARDWARE SETTINGS *(Continued)*

### SET DATE/TIME

This is a special case parameter. When this parameter is selected, press down on the Main Encoder to access the additional Set Date/Time parameters.

*TIP: Having an accurate clock setting will be of great benefit when reviewing Snapshots and other time-stamped data.*

#### SET DATE

Rotate the Master Encoder to highlight the SET DATE parameter, and use the Soft Knobs at the bottom of the screen to set the current:

Soft Knob 1: DAY

Soft Knob 2: MONTH

Soft Knob 3: YEAR

*NOTE: The actual date parameter assigned to each Soft Knob will vary depending on the current setting of the Date/Time Format parameter.*

#### SET TIME

Rotate the Master Encoder to highlight the SET TIME parameter, and use the Soft Knobs at the bottom of the screen to set the current:

Soft Knob 1: HOUR

Soft Knob 2: MINUTE

Soft Knob 3: AM/PM

Soft Knob 4: TIME ZONE ( +/- hours from GMT - Greenwich Mean Time)

*NOTE: Moog One can keep time using a 12-hour (AM/PM) or 24-hour clock; the clock mode is selected using the SET TIME FORMAT parameter. Obviously, if the 24-hour clock is chosen, the AM/PM option listed above will not be viewable.*

#### DATE/TIME FORMAT

This parameter will determine how the current date and time are displayed.

Soft Knob 1: DATE FORMAT (DD/MM/YYYY, MM/DD/YYYY, or YYYY/MM/DD)

Soft Knob 2: TIME FORMAT (12 HR or 24 HR)

#### CURRENT TIME

The current Moog One TIME and DATE set are displayed here.

### FAN MODE

Inside your Moog One, variable-speed fans work to maintain a consistent and safe internal operating temperature. The FAN MODE offers two settings, NORMAL and LOW.

#### NORMAL

This setting allows the fans to operate as normal, running at higher speeds to maintain a cooler interior. This is ideal for live performance, outdoor situations, and anywhere that fan noise is not an issue.

#### LOW

The LOW setting allows Moog One to operate at a higher internal temperature, which results in quieter overall operation in studio environments, while still maintaining a safe operating temperature. This setting works optimally in environments with a temperature at or below 75°F (24°C).

*NOTE: If LOW mode is selected and the environment that Moog One is in causes it to require further cooling, the fans will initiate at whatever speed is necessary to cool, protect, and ensure the long life of the instrument.*

## MIDI CONTROL

*Moog One MIDI and CV implementation will be greatly expanded over the coming weeks. New features are actively in development and will be ready soon. These will include: analog clock input and output, CV Pitch/Gate functionality, MIDI Clock output, and full MIDI CC and NRPN input and output.*

*Please register your instrument at [www.moogmusic.com/register](http://www.moogmusic.com/register) to receive the latest firmware updates as they become available.*

The MIDI CONTROL parameters define how Moog One will communicate with other devices, and determine what types of MIDI data is being shared. Use the Master Encoder to scroll through the parameters, and use the Soft Knobs at the bottom of the screen to set the value.

### **RECEIVE MIDI CLOCK** (OFF, ON)

When this parameter is set to On, Moog One will receive timing and tempo information from an external MIDI source, overriding the internal Master Clock.

### **RECEIVE MIDI START/STOP** (OFF, ON)

When this parameter is set to On, Moog One will receive Start and Stop commands from an external MIDI source. It is possible to receive Start and Stop command independent of the Clock signal.

## MIDI I/O

These MIDI Input/Output parameters dig a little deeper into how Moog One configures MIDI communication with other MIDI devices and instruments, including Channelizing and Merging, the use of DIN and/or USB ports, etc.

### LOAD FROM PRESET *(OFF, ON)*

The MIDI I/O settings made here can be saved as part of the current Preset. By setting the LOAD FROM PRESET parameter to On, these settings will be restored each time the Preset is loaded. With the LOAD FROM PRESET parameter Off, the MIDI I/O settings will remain in their current configuration.

### MIDI IN PORTS *(DIN, USB, DIN & USB)*

This parameter selects which MIDI input port(s) is actively receiving data. The choices are DIN, USB, or DIN & USB (both).

### MIDI IN ROUTE *(ALL SYNTHS, PER SYNTH)*

When set to ALL SYNTHS, incoming MIDI data can play all of the Synths in the current Preset using the single MIDI Channel specified using the MIDI IN CHANNEL ALL parameter that will be present and available. However, if the value is set to PER SYNTH, then each Synth in the current Preset can receive MIDI data on an independent MIDI Channel, by setting each of the MIDI IN CHANNEL SYNTH 1, MIDI IN CHANNEL 2, and MIDI IN CHANNEL SYNTH 3 parameters that will be present and available.

### MIDI IN ROUTE *(ALL SYNTHS SELECTED)*

#### MIDI IN CHANNEL ALL *(OFF, 1 to 16)*

This parameter selects the MIDI Channel that all of the Synths in the current Preset will use to receive data.

### MIDI IN ROUTE *(PER SYNTH SELECTED)*

#### MIDI IN CHANNEL SYNTH 1 *(OFF, 1 to 16)*

This parameter selects the MIDI Channel that Synth 1 will use to receive data.

#### MIDI IN CHANNEL SYNTH 2 *(OFF, 1 to 16)*

This parameter selects the MIDI Channel that Synth 2 will use to receive data.

#### MIDI IN CHANNEL SYNTH 3 *(OFF, 1 to 16)*

This parameter selects the MIDI Channel that Synth 3 will use to receive data.

**TIP:** *If you really only need one Synth – Synth 3, say – to receive on a separate channel, Use the Per Synth option and set Synth 1 and Synth 2 to the same channel, and Synth 3 to independent channel.*

### MIDI OUT PORTS *(DIN, USB, DIN & USB)*

This parameter selects which MIDI input port(s) is/are actively transmitting data. The choices are DIN, USB, or DIN & USB (both).

## **MIDI I/O** *(Continued)*

### **MIDI OUT ROUTE** *(ALL SYNTHS, PER SYNTH)*

When set to ALL SYNTHS, outgoing MIDI data from all three Synths in the current Preset will be sent on a single channel, as specified by the MIDI IN CHANNEL ALL parameter that will be present and available. However, if the value is set to PER SYNTH, then each Synth in the current Preset can transmit MIDI data on an independent MIDI Channel, by setting each of the MIDI OUT CHANNEL SYNTH 1, MIDI OUT CHANNEL 2, and MIDI OUT CHANNEL SYNTH 3 parameters that will be present and available.

### **MIDI OUT ROUTE** *(ALL SYNTHS SELECTED)*

#### **MIDI OUT CHANNEL ALL** *(OFF, 1 to 16)*

This parameter selects the MIDI Channel that all of the Synths in the current Preset will use to transmit data.

### **MIDI OUT ROUTE** *(PER SYNTH SELECTED)*

#### **MIDI OUT CHANNEL SYNTH 1** *(OFF, 1 to 16)*

This parameter selects the MIDI Channel that Synth 1 will use to transmit data.

#### **MIDI OUT CHANNEL SYNTH 2** *(OFF, 1 to 16)*

This parameter selects the MIDI Channel that Synth 2 will use to transmit data.

#### **MIDI OUT CHANNEL SYNTH 3** *(OFF, 1 to 16)*

This parameter selects the MIDI Channel that Synth 3 will use to transmit data.

## CV INPUTS

*Moog One MIDI and CV implementation will be greatly expanded over the coming weeks. New features are actively in development and will be ready soon. These will include: analog clock input and output, CV Pitch/Gate functionality, MIDI Clock output, and full MIDI CC and NRPN input and output.*

*Please register your instrument at [www.moogmusic.com/register](http://www.moogmusic.com/register) to receive the latest firmware updates as they become available.*

Moog One is equipped with five 1/4" TS Control Voltage (CV) Inputs on the rear panel – **CV IN 1** and **CV IN 2**, plus the PEDALS inputs for Expression – **EXP 1**, **EXP 2**, and **SUSTAIN**. All of these inputs can be configured to work with a variety of CV sources, from expression pedals to other modular, Eurorack, and standalone synthesizers.

### LOAD FROM PRESET (OFF, ON)

The CV INPUT settings made here can be saved as part of the current Preset. By setting the LOAD FROM PRESET parameter to On, these setting will be restored each time the Preset is loaded. With the LOAD FROM PRESET parameter Off, the CV INPUT settings will remain in their current configuration.

### CV IN 1; CV IN 2; EXP IN 1; EXP IN 2; PARAMETERS

The parameters listed below are identical for every CV INPUT; however, they are set individually using a repeating format for each CV INPUT.

### FUNCTION

This parameter selects the function/destination of the incoming control voltage signal arriving at the chosen jack.

### CV INPUT DESTINATIONS

NONE
NEXT PRESET
PREVIOUS PRESET
NEXT SET
PREVIOUS SET

## SUSTAIN IN

This feature is used to determine how Moog One will react to varying types of sustain pedal.

### FUNCTION (OFF, SUSTAIN PEDAL, SOSTENUTO PEDAL)

When set to SUSTAIN PEDAL, all notes played when a Sustain pedal his held will be sustained for as long as the pedal is held. When set to SOSTENUTO PEDAL, only the notes that are being held when the Sostenuto pedal is pressed will sustain. Subsequent notes that are played after the Sostenuto pedal is already held down do not sustain.

### SYNTH (SYNTH 1, SYNTH 2, SYNTH 3, SYNTH 1 & 2, SYNTH 1 & 3, SYNTH 2 & 3, ALL SYNTHS)

This parameter specifies which Synth the Sustain Pedal is being applied to. It can be applied to all three Synths, an individual Synth, or any combination of two Synths.

### SWITCH TYPE (Open and Closed)

This parameter allows Moog One to easily work with varying types of sustain pedals. The two options are OPEN and CLOSED, which adapt the Sustain Input to the two common types of pedal (normally-open or normally-closed).

## CV INPUTS *(Continued)*

### **SYNTHS** *(SYNTH 1, SYNTH 2, SYNTH 3, SYNTH 1 & 2, SYNTH 1 & 3, SYNTH 2 & 3, ALL SYNTHS)*

This parameter specifies which Synth the CV signal is being applied to. It can be applied to all three Synths, an individual Synth, or any combination of two Synths.

**NOTE:** *This parameter is unavailable and will default to the All Synths option when the FUNCTION parameter is set to INPUT TO MOD MATRIX.*

### **VOLTAGE MIN** *(-5.00V to +5.00V)*

This parameter allows the value of the minimum voltage setting to be freely set anywhere in the -5 to +5 Volt range.

### **VOLTAGE MAX** *(-5.00V to +5.00V)*

This parameter allows the value of the maximum voltage setting to be freely set anywhere in the -5 to +5 Volt range.

**TIP:** *Note that the VOLTAGE MIN parameter can be set to a higher value than the VOLTAGE MAX value, allowing inverted sweeps of a parameter value, etc.*

## CV OUTPUTS

*Moog One MIDI and CV implementation will be greatly expanded over the coming weeks. New features are actively in development and will be ready soon. These will include: analog clock input and output, CV Pitch/Gate functionality, MIDI Clock output, and full MIDI CC and NRPN input and output.*

*Please register your instrument at [www.moogmusic.com/register](http://www.moogmusic.com/register) to receive the latest firmware updates as they become available.*

Moog One is equipped with four 1/4" Control Voltage (CV) Outputs on the rear panel – **CV OUT 1**, **CV OUT 2**, **CV OUT 3**, and **CV OUT 4**. All of these outputs can be configured to work with a variety of CV destinations, from other modular and Eurorack synthesizers, to standalone CV synthesizers.

### **LOAD FROM PRESET** *(OFF, ON)*

The CV OUTPUT settings made here can be saved as part of the current Preset. By setting the LOAD FROM PRESET parameter to On, these setting will be restored each time the Preset is loaded. With the LOAD FROM PRESET parameter Off, the CV OUTPUT settings will remain in their current configuration.

### **CV OUT 1; CV OUT 2; CV OUT 3; AND CV OUT 4 PARAMETERS**

The parameters listed below are identical for every **CV OUTPUT**; however, they are set individually using a repeating format for each CV OUTPUT.

GATE	PAD X
PITCH WHEEL	PAD Y
MOD WHEEL	PAD PRESSURE
AFTERTOUCH	PAD GATE

### **SOURCE**

This parameter selects the source of the control voltage signal present at the chosen jack.

### **CV OUTPUT SOURCES**

#### **OUT VOLTAGE MIN** *(-5.00V TO +5.00V)*

This parameter allows the value of the minimum voltage setting to be freely set anywhere in the -5 to +5 Volt range. Volt range.

#### **OUT VOLTAGE MAX** *(-5.00V TO +5.00V)*

This parameter allows the value of the maximum voltage setting to be freely set anywhere in the -5 to +5 Volt range. Volt range.

## UTILITIES

The Utilities offer access to parameters and information that directly affect the operation of your Moog One. Here you can update the firmware, restore the default settings, verify the build version and date, view the IP address, and activate the Moog One Light Show.

### **LIGHT SHOW** (OFF, ON)

The Light Show feature is included because it's fun and sure to impress your friends. Basically, the Light Show causes the LEDs on the Moog One Front Panel to flash in an animated and repeating pattern while booting up. This feature is similar to one that first appeared in the mighty Memorymoog of the 1980s.

### **RESTORE DEFAULT SETTINGS** (SOFT BUTTON)

Selecting this option from the list in the right pane using the MASTER ENCODER will restore all Moog One SETTINGS to their factory default values; the screen prompt will read RESTORED DEFAULT SETTINGS.

**NOTE:** Restoring the Moog One Default Settings will NOT change, alter, or erase any Presets or Sequences.

## UPDATE FIRMWARE

From time to time, it may be necessary to update your Moog One firmware, as its operations are improved and performance is enhanced. The update data file can be downloaded from the Moog web site, and saved to a USB thumb drive (the drive must be formatted in a FAT format). The update file should be saved to the root directory of the USB drive, meaning not placed inside another folder. Insert the drive into the USB TYPE A (USB HOST) port found in the COMM section on the rear panel.

Once the USB thumb drive has been inserted, selecting this option from the list in the right pane will call up the CHECKING USB FOR NEW FIRMWARE message in the display, indicating that Moog One is scanning the USB drive in search of the FIRMWARE UPDATE file.

### **ERROR MESSAGES**

#### **USB STORAGE DEVICE NOT DETECTED**

If this error message appears, press the CANCEL Soft Button. Remove the USB drive, and reinsert the drive. If this does not work, reformat your USB drive ensuring that it is formatted in a FAT format.

#### **NO FIRMWARE FILES FOUND**

If this error message appears, press the CANCEL Soft Button. Remove the USB drive, and be sure the FIRMWARE UPDATE file is present on the root directory of the drive.



## UTILITIES *(Continued)*

### FIRMWARE VERSION

Selecting this option displays the current Firmware version. This is not an editable parameter.

### UI VERSION

Selecting this option displays the current version of the User Interface (the screens, buttons, and commands accessed through the Center Console). This is not an editable parameter.

### BUILD DATE

Selecting this option displays the Build Date for the Moog One operating system. This is not an editable parameter.

### BUILD INFO

Selecting this option displays the Build Info for the Moog One operating system. This is not an editable parameter.

### IP ADDRESS

Selecting this option displays the IP Address used to communicate with this specific Moog One via Internet Protocols. This is not an editable parameter.

## LIBRARY

While on the SETTINGS page, press the LIBRARY Soft Button at the top of the screen to open the LIBRARY page. From the LIBRARY page, you can create, select, and manage User Spaces; Import and Export all manner of Moog One data, and set the Category, Mood, and Group names for creating a searchable database. The left pane shows Library Category; the right pane shows the Menu Options. Rotating the Master Encoder will select and highlight an item from the list shown in the left pane. Pressing down on the Master Encoder will move the red-colored cursor to the right pane, where an individual item may be selected and highlighted by rotating the Master Encoder. The Library Category will remain highlighted in gray.

## UNDERSTANDING THE USER SPACE

The User Space is the current Moog One working environment. All of the Global settings, all of the Presets, Synths, Modulation Matrices, Sequences, Effect settings, and more exist within the confines of the User Space. The good news is that multiple User Spaces can be created, saved, and recalled – either from the internal memory, or from an external USB drive. This is a phenomenal advantage for the working musician involved with multiple projects at once; with User Space for the gigging cover band and a separate User Space for that in-progress solo album as an example. Touring musicians could keep a backup of their User Space and install it on a Moog One provided by the backline company. The important thing is that the User Space preserves more than just the Synths and Presets. All of the Global behavior, MIDI settings, Port and Pedal configurations, and even the knob behavior and LED brightness is saved to create a complete User Space.

## SWITCH USER SPACE

Select this command if you want to switch to a different User Space. The available user spaces are listed in the right pane. Highlight the User Space you wish to load and make active, then press the **MASTER ENCODER**. The selected User Space will load and the ACTIVE USER SPACE message will appear on the screen.

***NOTE:** You cannot load the Active User Space; in effect, it is already loaded. It will appear grayed-out in the list, and the message ACTIVE USER SPACE will appear when you attempt to highlight it for selection.*

## LIBRARY *(Continued)*

### EDIT USER SPACE

From this screen, you can edit the name of a User Space, Copy a User Space, or Add a new User Space.

### CREATING A NEW USER SPACE

Rotate the Master Encoder to highlight the +++ option from the list in the right pane. Pressing the **MASTER ENCODER** will open a new screen where you can name your new User Space, using the keyboard entry method. Once you have completed naming the User Space, pressing the CREATE FACTORY Soft Button will create a new User Space populated with factory presets, while pressing the CREATE EMPTY Soft button will create a new, empty User Space.

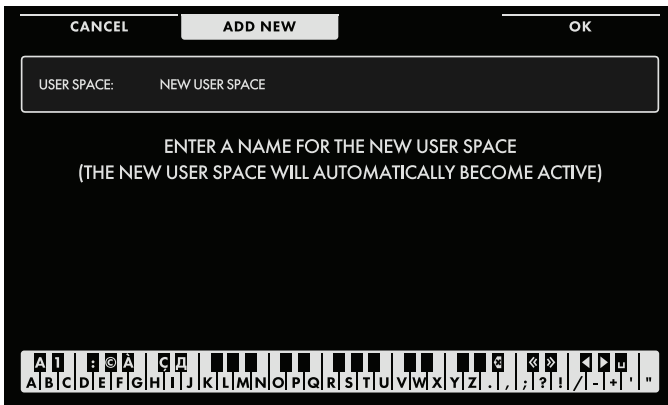

### ENTERING TEXT

Moog One allows you to enter names and text directly from the keyboard. The white keys (naturals) enter the characters; certain black keys (accidentals) have specific functions.

- Keys C#1 - D#2 select the character set.
- Key F#4 removes the current name and randomly generates a new name.
- Key G#4 clears all the characters in the screen.
- Key A#4 deletes the character to the left of the cursor.
- Keys C#5 and D#5, respectively, change the character immediately preceding the cursor to the previous or next symbol in the current character set, changing an M to an L or an N, for example with a single key press.
- Keys F#5 and G#5 move the cursor left or right, respectively.
- Key A#5 adds a space.

### EDITING A USER SPACE

Rotate the Master Encoder to highlight and select a User Space from the list in the right pane (the Active User Space cannot be edited). Pressing the **MASTER ENCODER** will open a new screen where you can rename the selected User Space, using the keyboard entry method. At this point, the Soft Buttons at the top of the screen provide three options.

#### OK

Once you have completed renaming the User Space, press the OK Soft Button; the previous screen will be recalled, and the newly renamed User Space will appear on the list. Press the CANCEL Soft Button to exit without renaming the User Space.

#### COPY

Press the COPY Soft Button to create a copy of the highlighted User Space. A new window will open with the message:

ENTER A NEW NAME FOR THIS USER SPACE  
COPY OF:

Add a name to the copied User Space, using the keyboard entry method. When you are done, press the OK Soft Button at the top of the screen; the previous screen will be recalled, and the new User Space you created by copying will appear on the list. If you enter nothing here and press the OK Soft Button, the new User Space created by copying will be named COPY OF [PREVIOUS USER SPACE NAME]. Press the CANCEL Soft Button to exit without creating a copy of the User Space.

#### CANCEL

Press the CANCEL Soft Button to exit without renaming or creating a copy of the selected User Space.

## LIBRARY *(Continued)*

### EXPORT

Using the EXPORT command, you can selectively copy any and all Moog One data to an external USB drive for safe storage and for transfer to another unit. Be sure a portable USB drive is available and securely inserted into the USB Type A (**USB HOST**) port in the COMM section of the rear panel. Once EXPORT is selected in the left panel, press down on the Master Encoder to move the red-colored cursor to the right pane. Here you can rotate the Master Encoder to select the type of data you wish to export.

The choices are:

- PRESETS
- SEQUENCES
- PERFORMANCE SETS
- EFFECTS PRESETS
- MOD MATRIX PRESETS
- GLOBAL SETTINGS
- ALL DATA (USER SPACE)

Once you have selected the type of data to export, press the **MASTER ENCODER**. Now the screen will show a list of all of the data of that type that is in the active User Space. So selecting Presets will show a list of all of the Presets, selecting Sequences will show Sequences, etc. In front of each individual item is a hollow check box. By rotating and pushing down on the Master Encoder, you can select an item from the list; the check box will now become solid.

**TIP:** *The onscreen prompt reminds you to PRESS ENCODER TO TOGGLE SELECTION ON/OFF.*

**NOTE:** *If no external USB drive is present, the screen prompt will read USB STORAGE DEVICE NOT DETECTED.*

In addition to selecting items individually, pressing the SELECT ALL Soft Button will select every item in the current list for export. The SELECT NONE Soft Button will deselect any previously selected items. Once you have made your selection(s), press the EXPORT Soft Button at the top of the screen. The selected data will be exported and saved to the USB drive.

**NOTE:** *Only the GLOBAL SETTING option does not provide a SELECT ALL or SELECT NONE Soft Button, because the only choice is the Global Data itself.*

To exit without exporting any data, press the CANCEL Soft Button.

### IMPORT

The opposite of the EXPORT command, you can use the IMPORT command to selectively load any and all Moog One data saved to a USB drive. Be sure the portable USB drive containing the data is available and securely inserted into the USB Type A (**USB HOST**) port located in the COMM section of the rear panel.. Once IMPORT is selected in the left panel, press down on the Master Encoder to move the red-colored cursor to the right pane. Here you can rotate the Master Encoder to select the type of data you wish to import.

The choices are:

- PRESETS
- SEQUENCES
- PERFORMANCE SETS
- EFFECTS PRESETS
- MOD MATRIX PRESETS
- GLOBAL SETTINGS
- ALL DATA (USER SPACE)

## LIBRARY (Continued)

### IMPORT (Continued)

Once you have selected the type of data to import, press the IMPORT Soft Button at the top of the screen. Now the screen will show a list of all of the data of that type that has been saved to the USB drive. So selecting Presets will show a list of all of the Presets, selecting Sequences will show Sequences, etc. In front of each individual item is a hollow check box. By rotating and pushing down on the Master Encoder, you can select an item from the list; the check box will now become solid.

**TIP:** The onscreen prompt reminds you to PRESS ENCODER TO TOGGLE SELECTION ON/OFF.

**NOTE:** If no external USB drive is present, the screen prompt will read USB STORAGE DEVICE NOT DETECTED.

In addition to selecting items individually, pressing the SELECT ALL Soft Button will select every item in the current list for import. The SELECT NONE Soft Button will deselect any previously selected items. Once you have made your selection(s), press the IMPORT Soft Button at the top of the screen. The selected data will be imported and saved to the current User Space

**NOTE:** Only the GLOBAL SETTING option does not provide a SELECT ALL or SELECT NONE Soft Button, because the only choice is the Global Data itself.

To exit without exporting any data, press the CANCEL Soft Button.

## UNDERSTANDING CATEGORIES, MOODS, AND GROUPS

Moog One allows the assigning of tags to each Preset and Synth as it is saved. These tags can be applied as search criteria when using the BROWSER pages to find either a specific Preset or Synth, or a suitable Preset or Synth based on these tags. The tag Criteria are TYPE, CATEGORY, MOOD, and GROUP. Of these, three are editable, so that each user may add and define their own Categories, Moods, and Groups. Only TYPE has fixed options - SINGLE, LAYER, SPLIT, and MULTI.

Each of the user-definable criteria includes some predefined Categories, Moods, and Groups to serve as an example, and to help make the pre-loaded factory Presets easy to search as well. So, the Categories will include tags such as BASS, LEAD, PAD, etc.

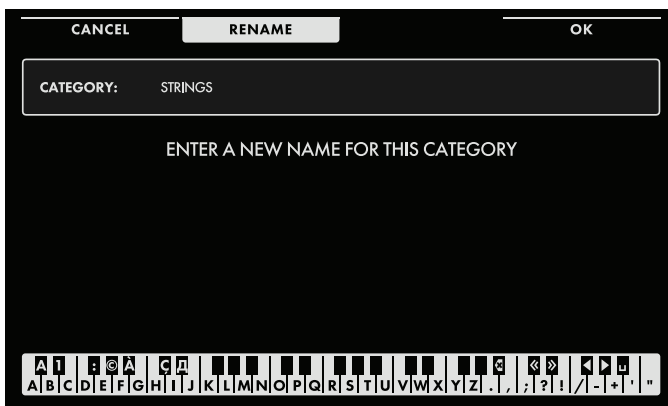

### ENTERING TEXT

Moog One allows you to enter names and text directly from the keyboard. The white keys (naturals) enter the characters; certain black keys (accidentals) have specific functions.

- Keys C#1 - D#2 select the character set.
- Key F#4 removes the current name and randomly generates a new name.
- Key G#4 clears all the characters in the screen.
- Key A#4 deletes the character to the left of the cursor.
- Keys C#5 and D#5, respectively, change the character immediately preceding the cursor to the previous or next symbol in the current character set, changing an M to an L or an N, for example with a single key press.
- Keys F#5 and G#5 move the cursor left or right, respectively.
- Key A#5 adds a space.

## **LIBRARY** *(Continued)*

### **EDITING CATEGORIES**

To add a new Category, rotate the Master Encoder to highlight the +++ option from the list in the right pane. Pressing the **MASTER ENCODER** will open a new screen where you can name your new Category, using the keyboard entry method. Once you have completed naming the Category, press the OK Soft Button; the previous screen will be recalled, and the new Category you created will appear on the list. To exit before creating the new Category, press the CANCEL Soft Button at the top of the screen.

To edit the name of an existing Category, rotate the Master Encoder to highlight the Category from the list in the right pane. Press the **MASTER ENCODER** to open a new screen where you can rename the Category using the keyboard entry method. Once you have completed renaming the Category, press the OK Soft Button; the previous screen will be recalled, and the renamed Category will appear on the list. To exit without renaming the Category, press the CANCEL Soft Button at the top of the screen.

### **EDITING MOODS**

To add a new Mood, rotate the Master Encoder to highlight the +++ option from the list in the right pane. Pressing the **MASTER ENCODER** will open a new screen where you can name your new Mood, using the keyboard entry method. Once you have completed naming the Mood, press the Ok Soft Button; the previous screen will be recalled, and the new Mood you created will appear on the list. To exit before creating the new Mood, press the CANCEL Soft Button at the top of the screen.

To edit the name of an existing Mood, rotate the Master Encoder to highlight the Mood from the list in the right pane. Press the **MASTER ENCODER** to open a new screen where you can rename the Mood using the keyboard entry method. Once you have completed renaming the Mood, press the OK Soft Button; the previous screen will be recalled, and the renamed Mood will appear on the list. To exit without renaming the Mood, press the CANCEL Soft Button at the top of the screen.

### **EDITING GROUPS**

To add a new Group, rotate the Master Encoder to highlight the +++ option from the list in the right pane. Pressing the **MASTER ENCODER** will open a new screen where you can name your new Group, using the keyboard entry method. Once you have completed naming the Group, press the OK Soft Button; the previous screen will be recalled, and the new Group you created will appear on the list. To exit before creating the new Group, press the CANCEL Soft Button at the top of the screen.

To edit the name of an existing Group, rotate the Master Encoder to highlight the Group from the list in the right pane. Press the EDIT Soft Button to open a new screen where you can rename the Group using the keyboard entry method. Once you have completed renaming the Group, press the Ok Soft Button; the previous screen will be recalled, and the renamed Group will appear on the list. To exit without renaming the Group, press the CANCEL Soft Button at the top of the screen.

## TUNING

While on the SETTINGS page, press the TUNING Soft Button at the top of the screen to open the TUNING page. From the TUNING page, you can adjust the Moog One's MASTER FREQUENCY and FINE TUNE.

Use the Soft Knobs at the bottom of the screen to set the value of the MASTER FREQUENCY and MASTER FINE TUNE parameters.

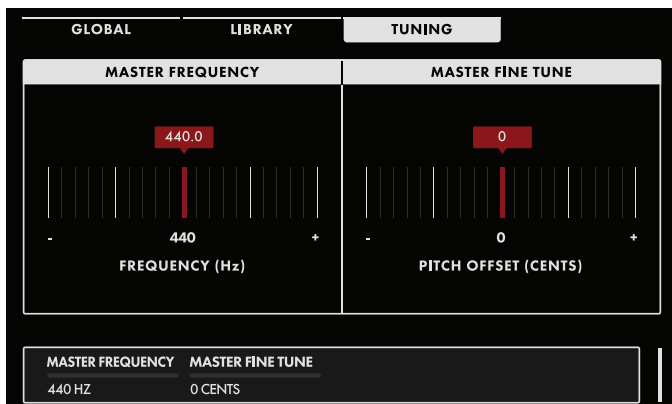

### **MASTER FREQUENCY** (400 Hz to 480 Hz)

This parameter controls the base frequency for equal-tempered tuning of the Moog One. This is the reference point for “concert pitch,” defined as the frequency of the A note above Middle C (MIDI Note # 69). The default value is 440 Hz.

### **MASTER FINE TUNE** (-100 CENTS to 0 CENTS to +100 CENTS)

This parameter provides a global offset in pitch affecting the entire Moog One. The range is +/- 100 cents; up or down one semitone. This allows Moog One to match the pitch of an instrument that cannot easily be re-tuned, such as an acoustic piano or pipe organ, or to match a previously recorded track, etc.

## SPECIFICATIONS

**SYNTHESIZER TYPE:** Polyphonic, Tri-timbral Analog Synthesizer

**SOUND ENGINE:** Analog (Digital Effects can be bypassed to maintain 100% analog signal path)

**POLYPHONY:** 8 or 16 voices

**KEYBED:** 61 full-size keys with Velocity and Aftertouch (Fatar TP-8S)

**CONTROLLERS:** Pitch Wheel, Modulation Wheel, X/Y Pad (with pressure-sensing and hold), Sustain Pedal input, EXP 1 Pedal input, EXP 2 Pedal input – all pedal functions are assignable

**PANEL CONTROLS:** 73 knobs and 144 buttons; LCD screen

**OSCILLATORS (x3):** Selectable Sawtooth wave with variable reset time or Triangle wave with variable rise and fall times, variable-width Pulse wave, Octave (32', 16', 8', 4', 2'), Frequency (+/- 7 semitones), Beat Frequency (+/- 7Hz), Wave Angle (Triangle and Saw), Pulse Width, Mix (blends the selected Triangle or Saw wave with the Pulse wave), FM routing and amount, and Hard Sync

**RING MODULATOR:** Selectable routing (1-2 or 2-3)

**DUAL SOURCE NOISE GENERATOR:** Selectable sources (Red + White, Red + Purple, and White + Purple) with Color Mix and dedicated ARS envelope

**MIXER:** Independent levels and filter routing for OSC 1, OSC 2, OSC 3, RING MOD, NOISE, and EXT IN

**FILTERS:** State-Variable Filter; Ladder Filter (Mixable, Parallel or Series operation)

**STATE VARIABLE:** Two -12dB per octave filters operating as one filter, configurable as NOTCH, BP, LP, and HP – with -12dB or -24dB slopes; Cutoff, Resonance, etc.

**LADDER FILTER:** Moog Ladder Filter with HP or LP options, and selectable filter slopes (-6db, -12db, -18dB, or -24dB); Cutoff, Resonance, etc.

**ENVELOPES (x3):** Delay, Attack, Hold, Decay, Sustain, and Release; variable curves per stage, plus multi-triggering, looping, latching, and sync

**LFOS (x4):** Dual-waveform categories with variable shapes (Triangle to Sine, variable-width Pulse, Saw to Ramp, S&H to Noise), assignable and variable transitions; fade-in/fade-out times, repeat count, phase start, etc.

**GLIDE:** Selectable glide type (LCR, LCT, EXP), gated glide, legato glide, glissando

**ARPEGGIATOR:** Per-Synth with octave range, pattern, direction, pendulum features, gate time, sync, etc.

**SEQUENCER:** 64-step per-Synth sequencer with step-editing and modulation capabilities

**SYNTH EFFECTS:** Dedicated in-line effect per SYNTH 1, SYNTH 2, and SYNTH 3 (When disengaged, the signal path is 100% analog)

**MASTER EFFECTS:** Dual monaural sends with stereo return, or single stereo send with stereo return. (Accessible by all three Synths - Eventide® Reverbs are available on the Master Buss only)

**BROWSER:** Stores tens of thousands of PRESETS and TIMBRES with definable Categories, Tags and Labels to aid search results. TIMBRES can be loaded to and played by any Synth

## SPECIFICATIONS

**PERFORMANCE SETS:** Create, save, and manage up to 128 Performance Sets offering single-button access to up to 64 PRESETS

**SETTINGS:** Access to pages for managing Libraries, Tuning features, plus Utilities such as updates, configuring ins and outs, etc.

**MOD MATRIX:** Provides the ability to map modulation sources to destinations at will, using either controllers or addressable transforms to articulate the modulation signal

**VOICE ALLOCATION:** Mono or Poly voice count per Synth, unison/mono detune (48 oscillator max.), Chord Memory, plus voice stealing/sharing options

**SNAPSHOT, COMPARE:** Built-in tools for saving and comparing during programming

**VCA SECTION:** VCA level per Synth, Pan per Synth

**OUTPUT SECTION:** Master Volume and Headphones volume controls

**AUDIO OUTPUTS:** Main L, Main R (1/4" TRS balanced; TS unbalanced compatible)

**SUB OUTPUTS:** Sub 1, Sub 2 (1/4" TRS balanced; TS unbalanced compatible)

**AUDIO INSERTS:** Insert 1, Insert 2, Insert 3, Insert 4 (1/4" TRS Send / Returns- Can be used as TS monaural outs)

**EXTERNAL MIC/LINE INPUT:** XLR + 1/4" TRS combo jack with trim knob

**EXTERNAL LINE INPUT:** 1/4" TRS (TS compatible)

**HEADPHONES:** 2x Stereo 1/4" jacks (located on the front edge of the Left Hand Controller)

**CONTROL VOLTAGE INPUTS:** CV IN 1, CV IN 2 (1/4" TS)

**CONTROL VOLTAGE OUTPUTS:** CV OUT 1, CV OUT 2, CV OUT 3, CV OUT 4 (1/4" TS)

**PEDAL INPUTS:** Sustain, EXP 1, EXP 2, (1/4" TRS; configurable through the Modulation Matrix, or as 1/4" TS CV Inputs)

**MIDI:** Five-pin DIN ports for MIDI IN, OUT, and THRU; MIDI over USB

**USB:** HOST port (allows system and data backup)

**USB:** CLIENT port (connects to other USB gear, computers, etc.; accommodates class-compliant peripherals)

**LAN:** Network port (CAT-5 Ethernet) for future expansion and remote service

**WEIGHT:** 45 lbs. / 20.4 kg (approximate)

**DIMENSIONS (W x D x H):** 42 x 20 x 7 (inches); 107 x 51 x 18 (cm)



## SERVICE AND SUPPORT INFORMATION

### MOOG'S STANDARD WARRANTY

Moog warrants its products to be free of defects in materials or workmanship and conforming to specifications at the time of shipment. The Warranty Period is one year from the date of purchase. If, in Moog's determination, it has been more than five years since the product shipped from our factory, it will be at Moog's discretion whether or not to honor the warranty without regard to the date of the purchase. During the Warranty Period, any defective products will be repaired or replaced, at Moog's option, on a return-to-factory basis. This warranty covers defects that Moog determines are no fault of the user.

The Moog Limited Warranty applies to USA purchasers only. Outside the USA the warranty policy and associated service is determined by the laws of the country of purchase and supported by our local authorized distributor. A listing of our authorized distributors is available on [moogmusic.com](http://moogmusic.com).

If you purchase outside of your country, you can expect to be charged for warranty as well as non-warranty service by the service center in your country.

### RETURNING YOUR PRODUCT TO MOOG MUSIC

You must obtain prior approval in the form of an RMA (Return Material Authorization) number from Moog before returning any product. Email [techsupport@moogmusic.com](mailto:techsupport@moogmusic.com) for the RMA # via email or call us at (828) 251-0090. All products must be packed carefully and shipped with the Moog supplied power adapter. The Moog One must be returned in the original inner packing including the cardboard inserts. Sorry, the warranty will not be honored if the product is not properly packed. Once you have received the RMA# and carefully packed your Moog, ship the product to Moog Music Inc. with transportation and insurance charges paid, and include your return shipping address.

**MOOG MUSIC**  
160 Broadway St.  
Asheville NC, 28801

### WHAT WE WILL DO

Once received, we will examine the product for any obvious signs of user abuse or damage as a result of transport. If the product abused, damaged in transit, or is out of warranty, we will contact you with an estimate of the repair cost. Warranty work will be performed and Moog will ship and insure your product to your United States address free of charge.

### HOW TO INITIATE YOUR WARRANTY

Please initiate your warranty online at [www.moogmusic.com/register](http://www.moogmusic.com/register). If you do not have web access, please call (828) 251-0090 to register your product.

### CARING FOR THE MOOG ONE

Clean the Moog One with a soft, dry cloth only – do not use solvents or abrasive detergents. Heed the safety warnings at the beginning of the manual. Don't drop the unit.

**AN IMPORTANT NOTE ABOUT SAFETY:** *There are no user serviceable parts in the Moog One. Refer all servicing to qualified personnel only.*

©2018 MOOG MUSIC INC. | 160 Broadway St. Asheville, NC 28801

Moog is a registered trademark of Moog Music Inc.

The Moog Wordmark is a registered trademark of Moog Music Inc.

The Moog Icon is a registered trademark of Moog Music Inc.

Moog One is a trademark of Moog Music Inc.

All rights reserved to Moog Music Inc. on all text & graphics here within.

Phone: 828.251.0090

Email: [info@moogmusic.com](mailto:info@moogmusic.com)

Website: [www.moogmusic.com](http://www.moogmusic.com)

