

HERCHILD

MODEL 670

DUAL CHANNEL TUBE COMPRESSOR
AMERICAN HERITAGE



USER MANUAL



September/2022 Rev.

INTRODUCTION

Thank you for choosing the **HERCHILD Model 670**. Heritage Audio is dedicated to bringing you ‘the sound of yesterday for tomorrow’. We specialize in capturing that unique, enticing sound that everybody has fallen in love with. For years engineers, producers and musicians have been yearning for that classic vibe. Usually the only option is to search for old, used original equipment that is almost always in a questionable state of operation. This brings with it a whole lot of other issues, making the experience less than desirable. Not to mention the very high prices asked for this equipment, which makes them virtually unobtainable for the great majority. Now it’s possible to obtain that same sound with a brand new piece that will give you all the problem-free, heavy-duty use you’ll need for years of music making history.

Peter Rodriguez
CEO
Heritage Audio - Madrid, Spain



© 2022 Heritage Audio S.L. is the sole owner of the copyright of all information and drawings contained in this manual which are not to be copied or reproduced by any means or disclosed in part or whole to any third party without written permission.

Heritage Audio reserves the right to alter specifications without notice. The information in this manual has been carefully checked and is believed to be accurate at the time of publication. However, no responsibility is taken by us for inaccuracies, errors or omissions nor any liability assumed for any loss or damage resulting either directly or indirectly from use of the information contained within it.

TABLE OF CONTENTS

INTRODUCTION	2
CONTENTS	2
DESCRIPTION	3
GETTING STARTED	4-5
DC THRESHOLD SETTINGS	6
TIME CONSTANT SETTINGS	6
APPLICATIONS	7-11
SPECIFICATIONS	12
SIGNAL FLOW	12
TROUBLE SHOOTING	13
WARRANTY STATEMENT	14
REGISTRATION	14
RECALL SHEETS	15
RACKING OPTIONS	16



DESCRIPTION

The HERCHILD model 670 is our newest release and one of the products we are proudest of. A tube-based audio compressor with a striking resemblance to one of the most famous compressors of all time, the Fairchild 670. After years of research, development and new designs we are finally ready to release this beast to the public. While making sure to capture all the lush sound and mystique of the original we were able to improve on several aspects and offer a more reliable, more durable, modern version that will last you for decades to come. The HERCHILD Model 670 contains nothing less than 22 tubes and 9 transformers to achieve that indistinguishable, classic, triumphant sound that we all know and love. The original intention of the his historical compressor was to be used in the cutting of lacquer masters for vinyl albums, but it soon became an industry standard for getting that all enveloping sound that takes us to another level. The Fairchild Model 670 is found on almost all of the classic releases in the 60's and 70's, defining the sound of a generation...or two.

The granddaddy of all tube-based compressors had a relatively limited amount produced, somewhere between 500 and 1,000 units. Therefore, some 60 years later there are only a small amount that remain today. There are even fewer that are totally usable as years have gone by since it's late 1950's introduction so many units aren't exactly as they once were. Maintenance is obligatory on a high-end piece like this and unfortunately, too many of them have simply been neglected and aren't up to their optimal specifications. This means an alternative is needed. And this is where the HERCHILD Model 670 comes in, to once again offer that magic that only this compressor design can.

Our HERCHILD Model 670 offers a couple of new and ever so helpful features. The user now has immediate access to the all important **DC THRESHOLD**. This control basically combines adjustments to the progressively developing curved **RATIO** and the **KNEE** simultaneously through 4 different settings varying from a gentle slope to a more pronounced and aggressive slope. This control really does put sound manipulation right at your finger tips as opposed to the original's out of reach and inconvenient screw adjuster. The other main addition is something no modern day studio can be without, a side chain filter. With the **SC FILTER** on the HERCHILD Model 670 you have 4 different frequencies to choose from: 50, 100, 200 and 350 Hz. Using this feature you now have lots more control over just how much compression will be applied as you can make it less sensitive to the lower frequencies therefore allowing more compression where you need it and for the track to stay powerful.

The HERCHILD Model 670 also has the **AGC** section to determine which mode it will work in. There are 4 modes of operation to choose from: **IND**, **LINK**, **LAT VERT** & **LAT VERT LINK**. The **IND & LINK** modes are for normal stereo operation. **IND** give you independent control for each channel while **LINK**, obviously, links the two channels operation together and determines the compression applied on whichever channel is producing the most gain reduction at any given moment, and this amount will be used for both channels. The **LAT VERT** mode is originally from the days of using a cutting lathe to prepare vinyl records. It was crucial to carefully decide the depth and the width of the grooves, so you had precise control over both aspects in this mode. Nowadays, people have discovered the advantages of mixing and mastering with **MID/SIDE** processing as it allows you creative control over the center and side signals of a stereo track separately. **LAT VERT** is the equivalent to **MID/SIDE** and when used properly it really gives you the control to make your songs sound wider, deeper and more focused. And the last option is **LAT VERT LINK** and is again for **MID/SIDE** processing but this time with the two channels linked together and controlled by taking the average from the two channel's settings to determine what the overall control will be.



Choose the correct voltage depending on the country where used. 110 V or 240 V. This is **EXTREMELY** important as a mistake here could be disastrous.

Do not open. No user serviceable parts inside. Risk of shock. Please do **NOT** open!

There is an extra fuse included in the fuse holder. If needed replace the blown fuse with this one. If the problem persists get in contact with your official repair service. Do **NOT** try to service it on your own.

Make sure to leave at least one unit of rack space above and below the unit to guarantee proper ventilation.



Tube replacement is possible from the outside. Opening the unit is not necessary and should not be done under any circumstance. Very high voltage inside!

Big changes in temperature can be detrimental to the tubes and is best to avoid.

GETTING STARTED

FRONT



1-METER ADJUSTMENT SCREW: This is not meant to be user adjustable. We recommend not adjusting this and to contact an official repair service.

2-POWER SWITCH: Turns the unit on or off.

3-RED JEWEL INDICATOR LIGHT: Simply indicates that the equipment is 'On'.

4-VU METER: Indicates GAIN REDUCTION.

5-ZERO ADJUSTMENT SCREW: Use this screw to set the meters to 0 dB on the VU meter when there is no compression happening. It is normal for this setting to drift for the first 30 minutes of operation.

6-METERING: Knob to choose the readout of the VU meter, either for adjusting the balance of the tubes or the gain reduction being applied.

7-BALANCE ADJUSTMENT SCREW: Use this screw to balance the circuit for optimum performance based on the particular set of tubes installed.

8- INPUT GAIN CONTROL: This knob is used to control the amount of input gain applied. This is actually an attenuator that reduces the the input by up to -20 dB.

9- AC THRESHOLD: The threshold knob determines when the compression begins. It's used to decide when and how much gain reduction takes place. When in the fully counter-clockwise position, the HERCHILD Model 670 will not compress at all. As the threshold control is turned clockwise, the amount of compression will progressively increase.

10- DC THRESHOLD: Here you decide what kind of curve will be applied to the compression. It is similar to a knee and ratio effect combined. So at the most counter-clockwise position the HERCHILD Model 670 responds like a limiter with immediate and aggressive action happening as soon as the AC THRESHOLD is passed. While as you turn it clockwise more of gradual, progressive effect occurs until you have a very slight compression happening at all times.

11-SC FILTER: This is a side chain filter applied only to the control signal to decide if and where the HERCHILD Model 670 will be less sensitive to certain frequencies. There are 5 choices available: 50, 100, 200, 350 Hz and OFF.

12-TIME CONST: Here you have 6 options for the attack and release timings giving you combinations for fast and slow timings. (Please see the TIME CONSTANT Section for exact timings.)

13-AGC - Here you choose between 4 different modes of operation for the HERCHILD Model 670.

- The first being 'IND' and refers to each channel being individual with it's own independent control.
- The next, 'LINK' will tie the channels together and base the compression applied on whichever channel is producing the most compression to be used for both channels. This is used for stereo operation.
- The 'LAT VERT' takes us way back to the vinyl cutting days and refers to the lateral and vertical adjustments when cutting grooves onto vinyl records. This is similar to what we refer today as Mid & Side. A very effective way of widening a stereo image and improving and strengthening the center image. Here the upper channel of the HERCHILD Model 670 controls the 'MID' information and the lower channel controls the middle or 'SIDE' information.
- 'LAT VERT LINK' is the same but with the controls linked together, once again deriving the overall compression from whichever channel is producing the most at any given moment.

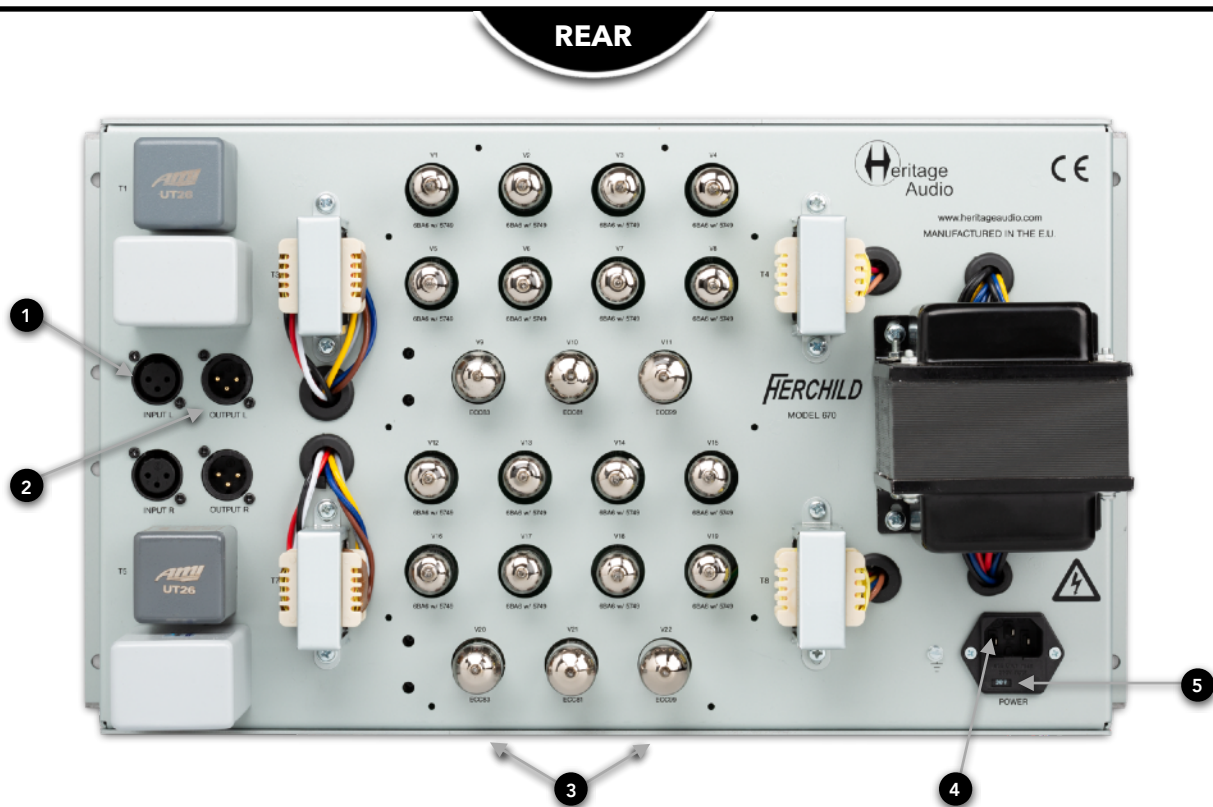

1-LINE INPUTS (x2): Female Gold Plated XLR Connector.

2-LINE OUTPUTS (x2): Male Gold Plated XLR Connector.

3-TUBES: (22) User changeable valves with easy access.

4-POWER INPUT: IEC standard power input connector.

5-VOLTAGE SELECTOR: Here you can select the correct voltage input according to the country you are in.

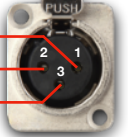
All XLRs are:	MALE XLR	FEMALE XLR
Pin 1: GND		
Pin 2: Hot	Hot (+)	Hot (+)
Pin 3: Cold	Cold (-)	Cold (-)

DC THRESHOLD SETTINGS



The **HERCHILD Model 670**, just like the original, uses a progressively developing ratio curve so it is not possible to describe the ratio as 2:1, 10:1 or anything so exact.



TIME CONSTANT SETTINGS



	ATTACK	RELEASE
1	.2 ms	.3 Seconds
2	.2 ms	.8 Seconds
3	.4 ms	2 Seconds
4	.4 ms	5 Seconds
5	.4 ms	2 Seconds for individual peaks 10 Seconds for multiple peaks
6	.2 ms	.3 Seconds for individual peaks 10 Seconds for multiple peaks 25 Seconds for consistently high program level

APPLICATIONS

VOICE TRACK INSERT

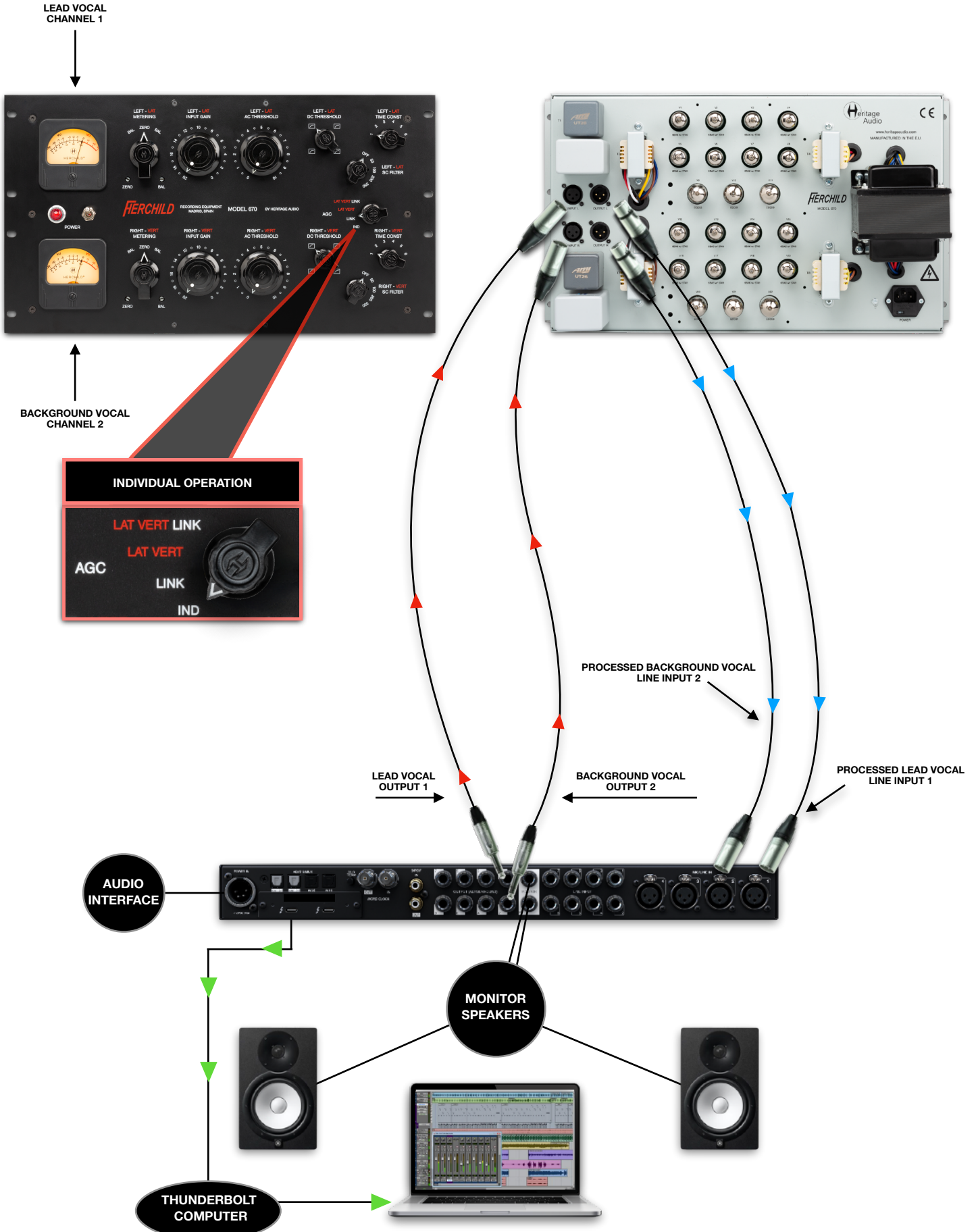

INSTRUMENT RECORDING

INDIVIDUAL OPERATION

LAT VERT LINK
 LAT VERT LINK
 AGC
 LINK
 IND

BASS GUITAR CHANNEL 1

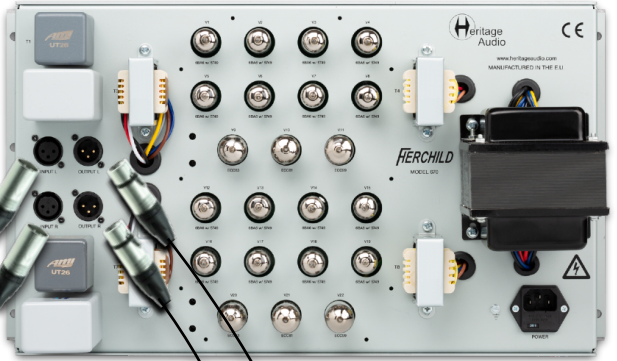

ELECTRIC GUITAR CHANNEL 2

BASS OUTPUT - CH 1

GUITAR OUTPUT - CH 2

PROCESSED ELECTRIC GUITAR LINE INPUT 2

PROCESSED BASS GUITAR LINE INPUT 1

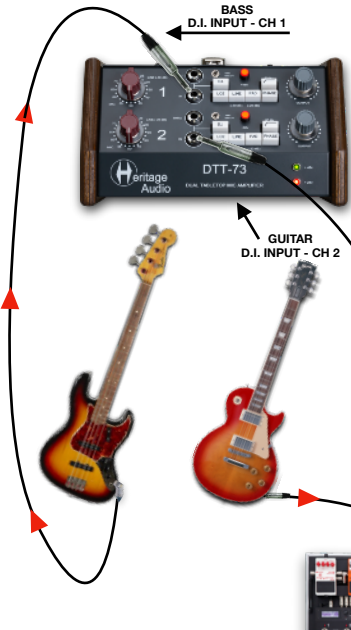

AUDIO INTERFACE

MONITOR SPEAKERS

THUNDERBOLT COMPUTER



MIX STEREO BUSS INSERT

MIX LEFT CHANNEL 1



MIX RIGHT CHANNEL 2

TWO POSSIBLE OPTIONS
- LINKED STEREO
- LINKED MID/SIDE

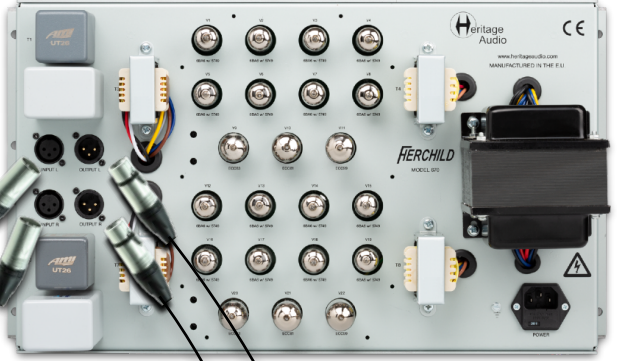

MIX LEFT OUTPUT 1

MIX RIGHT OUTPUT 2

PROCESSED MIX RIGHT LINE INPUT 2

PROCESSED MIX LEFT LINE INPUT 1

AUDIO INTERFACE



MONITOR SPEAKERS



THUNDERBOLT COMPUTER



MASTERING

Use a blank 1 unit rack panel to allow space for the HERCHILD to ventilate correctly.

TWO POSSIBLE OPTIONS
- LINKED STEREO
- LINKED MID/SIDE

LAT VERT LINK
AGC LAT VERT LINK IND

HERCHILD 670 LEFT & RIGHT LINE INPUTS

HERCHILD 670 LEFT & RIGHT LINE OUTPUTS

MOTORCITY EQ LEFT & RIGHT LINE OUTPUTS

SUCCESSOR LEFT & RIGHT LINE OUTPUTS

MASTERED MIX LEFT & RIGHT LINE INPUTS

STEREO MIX DAW LEFT & RIGHT LINE OUTPUTS

AUDIO INTERFACE

MONITOR SPEAKERS

THUNDERBOLT COMPUTER

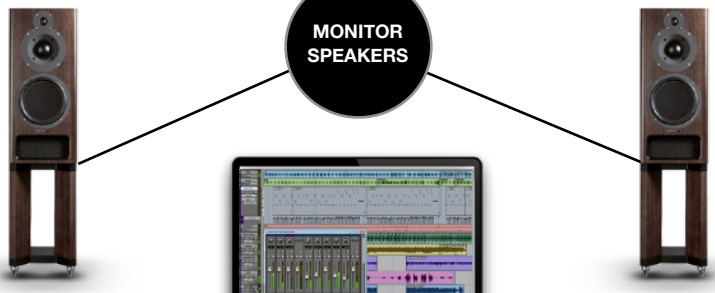

BASS GUITAR COMPRESSION TRIGGERED FROM BASS DRUM

LINKED OPERATION NECESSARY

LAT VERT LINK
 AGC LAT VERT
 LINK IND

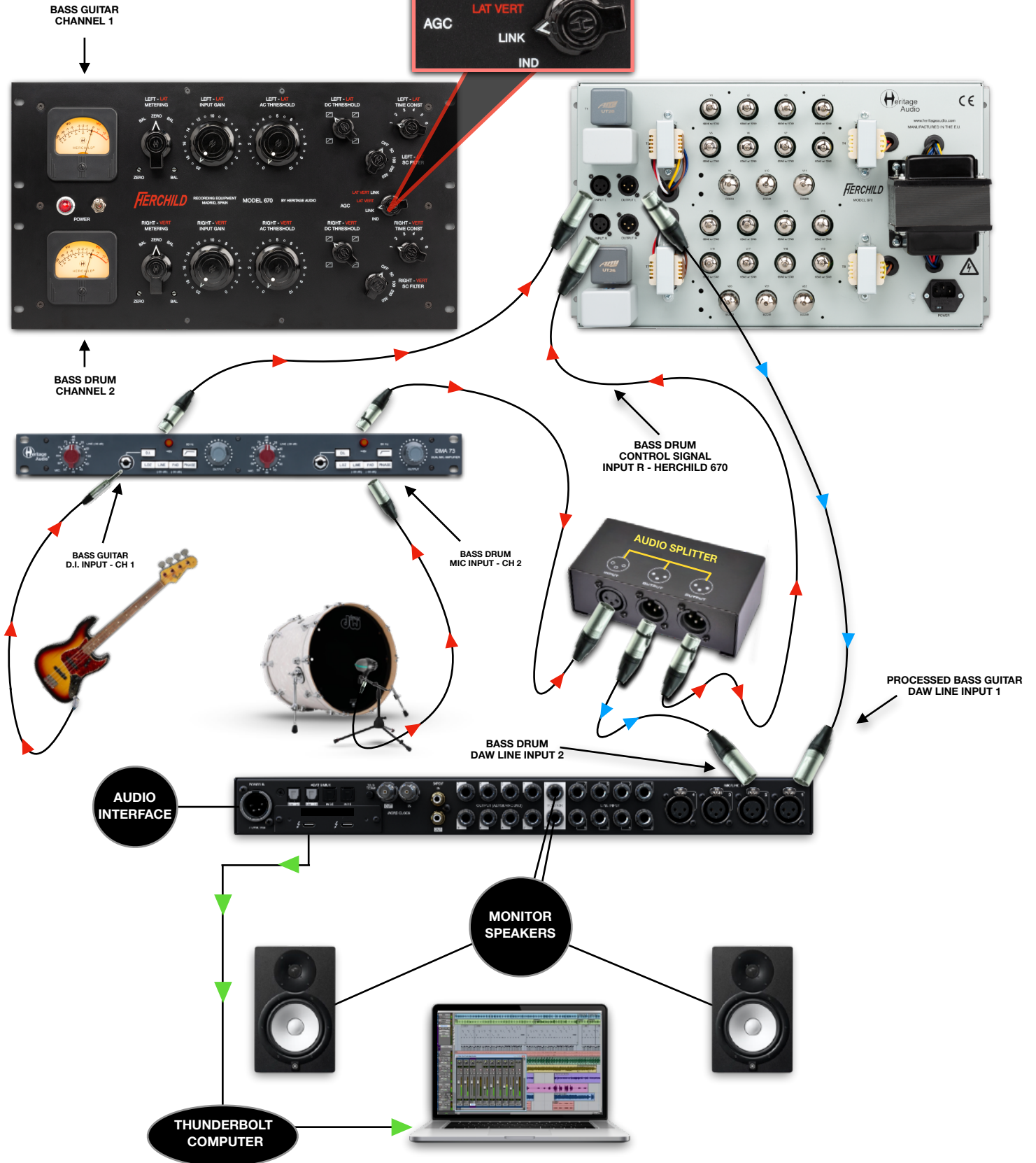

SPECIFICATIONS



- **Gain:** Up to approx. 12 dB.
- **Input Impedance:** 2 K Ω .
- **Output Impedance:** 600 Ω .
- **Output Level:** +30 dBu clipping point.
- **Frequency Response:** 20 Hz to 20 kHz \pm 1 dB.
- **Signal To Noise Ratio:** 120 dB.
- **Self Noise:** Less than -82 dBu.
- **Harmonic Distortion:** Less than 1 % at any level up to +18 dBu output (no limiting).
- **Dimensions (W x H x L):** 482 mm x 265 mm (6 Rack units) x 200 mm.
- **Weight:** 13,3 Kg

SIGNAL FLOW

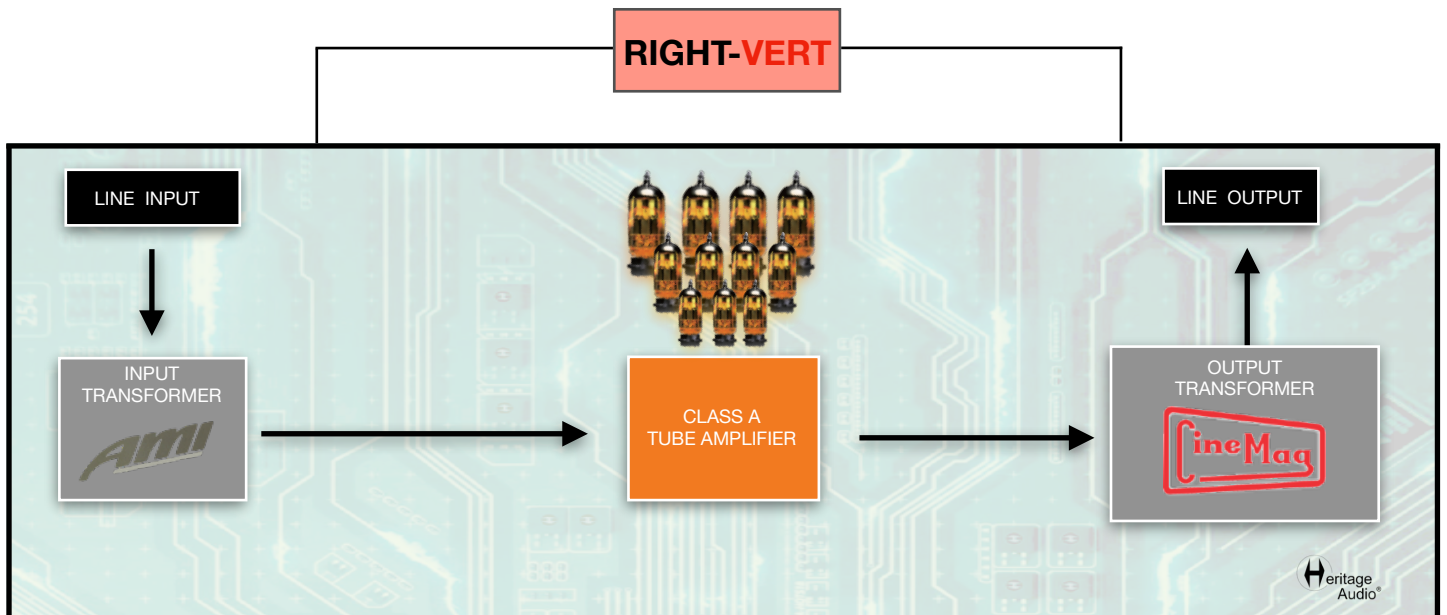
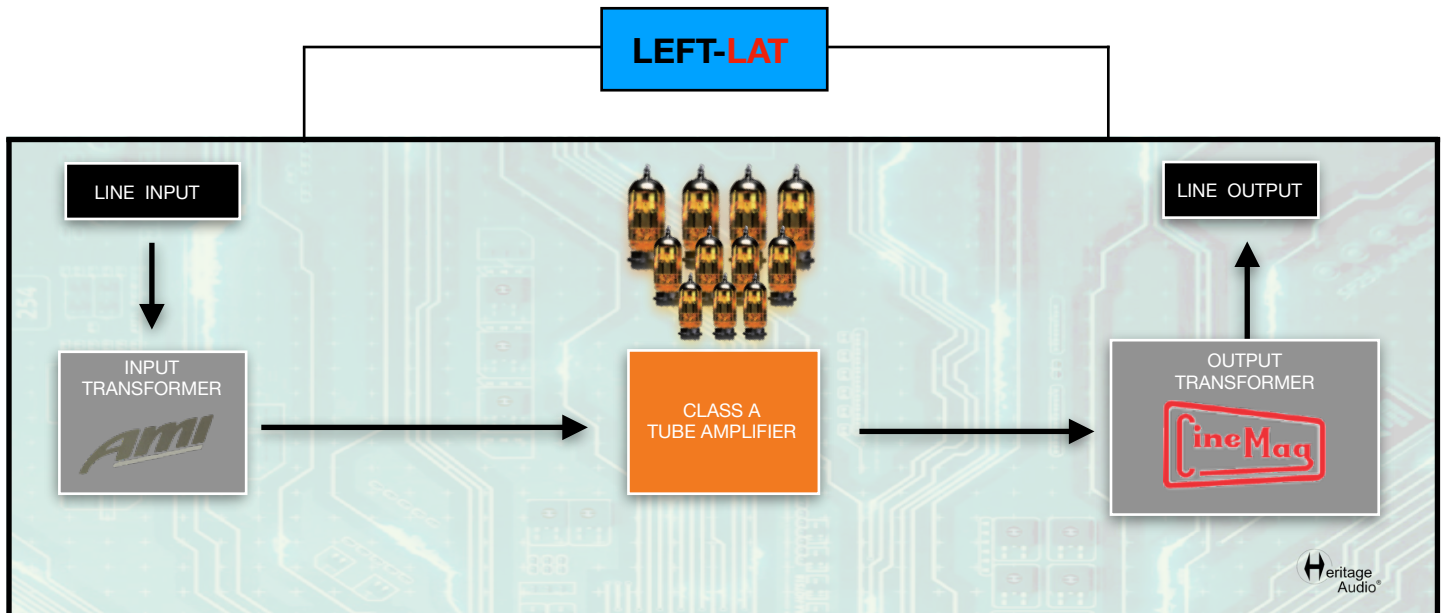

TROUBLE SHOOTING



PROBLEMS	SOLUTIONS
There is almost no sound coming from the HERCHILD Model 670.	Make sure you have raised the INPUT GAIN to a sufficient level.
There doesn't seem to be any compression taking place.	Make sure you have adjusted the AC THRESHOLD level to a reasonable setting.
I'm getting way too much compression for what I need.	Try lowering the AC THRESHOLD .
I'm still getting way too much compression for what I need.	Try adjusting the SC FILTER to make the HERCHILD Model 670 less sensitive to the lower frequencies.
The HERCHILD Model 670 does not seem to be reacting as it should.	Have you allowed the recommend 30 minutes for the unit to warm up?
The readings on the VU meter don't seem to correspond with what is actually happening.	Sounds like it's time for some calibrating.
The compression I am getting is altogether too aggressive for what I am looking for.	Try a different setting on the DC THRESHOLD to alter the Ratio/Knee.
The compression I am getting is still altogether too aggressive for what I am looking for.	Try a different setting on the TIME CONST selector to ease the attack and release controls. (See Time Constant Settings for exact timings).
The compressor isn't responding the way it should.	Double check to make sure you have selected the desired mode of operation in the AGC section.
The compressor seems to be heating up excessively.	Have you installed a blank rack panel above and below the unit to assure proper ventilation? - - - MORE INFORMATION ON PAGE 16 - - -

- For any further doubts or questions please get in contact with us at: support@heritageaudio.com

WARRANTY STATEMENT

LIMITED 2 YEAR WARRANTY

Heritage Audio **HERCHILD Model 670** is warranted by Heritage Audio SL to be free from defects in materials and workmanship for the period of 2 years to the original purchaser. In the event of such defects, the product will be repaired without charge or, at our option, replaced with a new one if delivered to Heritage Audio prepaid, together with a copy of the sales slip or other proof of purchase date. The warranty excludes problems due to normal wear, abuse, shipping damage or failure to use the product in accordance with the specifications.

Heritage Audio shall not be liable for damages based upon inconvenience, loss of use of the product, loss of time, interrupted operation or commercial loss or any other damages, whether incidental, consequential or otherwise.

This warranty is not transferable.

Heritage Audio and the Heritage Audio “H” logos are registered Trademarks owned and/or licensed by Heritage Audio.



REGISTRATION

Please visit our website: <https://heritageaudio.com/registration/>

RECALL SHEETS

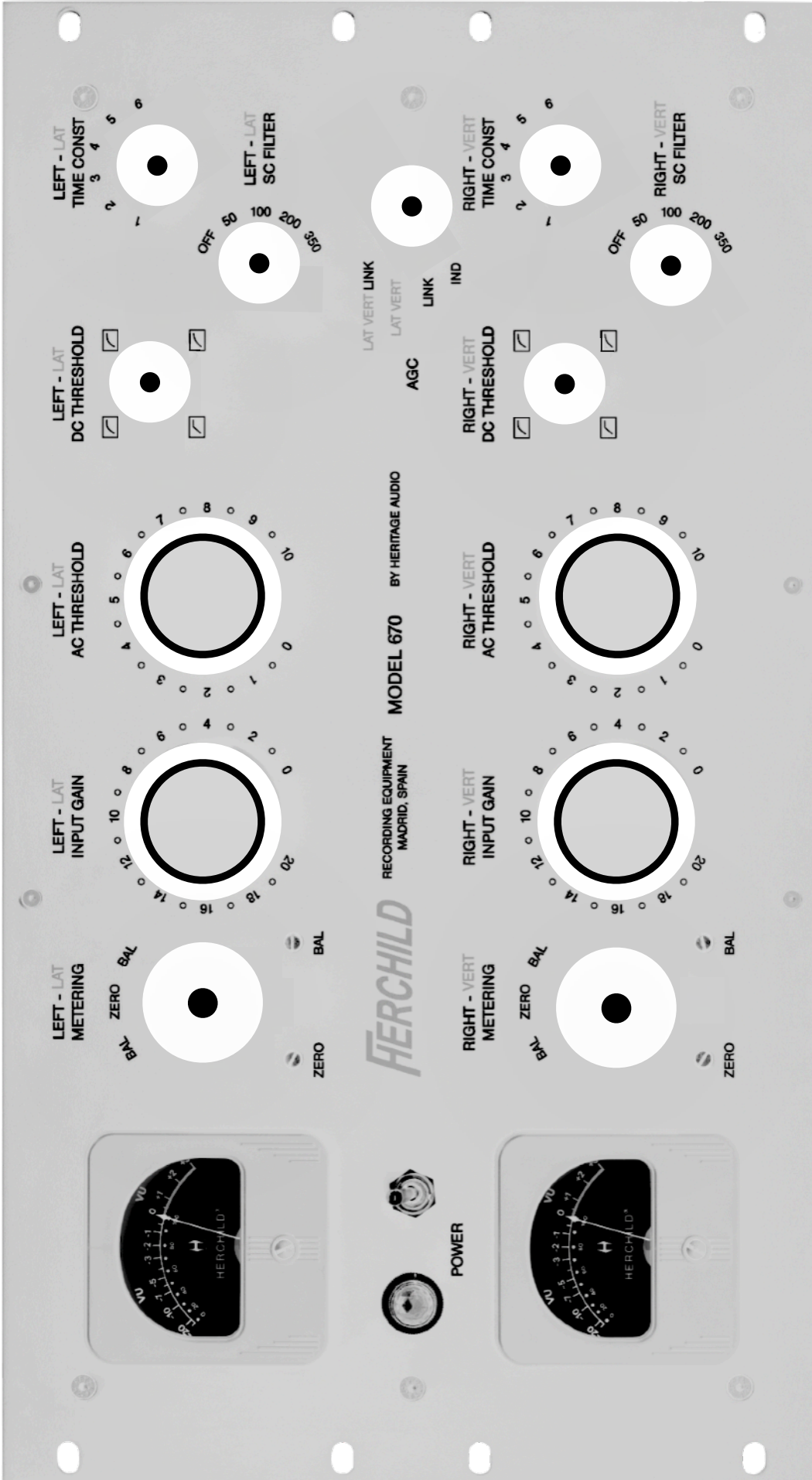

Session / Title: _____ Track: _____ Connected Equipment: _____

Date: _____ Instrument: _____ Notes: _____

RACKING OPTIONS

While we strongly recommend leaving at least a full 1 unit of rack space above and below the HERCHILD, we have equipped it with additional racking holes to provide the option to reposition the unit to allow only 1/2 rack space.



**Avoid at all costs! Your HERCHILD needs to breathe!
Never install anything directly above and below it.**



Using the inner set of holes allows you to have 1 full rack unit of space above and below.



Using the outer set of holes allows you to have 1/2 rack unit of space above and below.



www.heritageaudio.com

HERITAGE AUDIO. C/ Alfonso Gómez, 38, 3C. 28037 Madrid – Spain. Tel: +34 917 266 189

info@heritageaudio.com

