

BT-500 v2.0

BLUETOOTH STREAMING MODULE

500 Series



USER MANUAL



INTRODUCTION

Thank you for choosing the **BT-500 v2.0**. Heritage Audio is dedicated to bringing you ‘the sound of yesterday for tomorrow’. We specialize in capturing that unique, enticing sound that everybody has fallen in love with. For years engineers, producers and musicians have been yearning for that classic vibe. Usually the only option is to search for old, used original equipment that is almost always in a questionable state of operation. This brings with it a whole lot of other issues, making the experience less than desirable. Not to mention the very high prices asked for this equipment, which makes them virtually unobtainable for the great majority. Now it’s possible to obtain that same sound with a brand new piece that will give you all the problem-free, heavy-duty use you’ll need for years of music making history.

Peter Rodriguez
CEO
Heritage Audio - Madrid, Spain



© 2022 Heritage Audio S.L. is the sole owner of the copyright of all information and drawings contained in this manual which are not to be copied or reproduced by any means or disclosed in part or whole to any third party without written permission.

Heritage Audio reserves the right to alter specifications without notice. The information in this manual has been carefully checked and is believed to be accurate at the time of publication. However, no responsibility is taken by us for inaccuracies, errors or omissions nor any liability assumed for any loss or damage resulting either directly or indirectly from use of the information contained within it.

TABLE OF CONTENTS

INTRODUCTION	2
CONTENTS	2
DESCRIPTION	3
GETTING STARTED	4
APPLICATIONS	5
SPECIFICATIONS	6
TROUBLE SHOOTING	7
WARRANTY STATEMENT	8
REGISTRATION	8
RECALL SHEETS	9



DESCRIPTION

500 SERIES BLUETOOTH STREAMING MODULE

Heritage Audio is pleased to announce the latest addition to their growing lineup of 500 Series products, the BT-500 v2.0 streaming module. This new product is based on our popular BT-500 which was Heritage's entry into the 'Internet of Things' anticipating a whole new, additional line of products to the already acclaimed analog classics.

No other current product, be it 500 series, rack or other format, has the features of the BT-500 v2.0, which finally solves the connectivity problems of mobile devices in a professional studio environment.

Finally! The BT-500 v2.0 is here to save the day and solve the problem you didn't even know you had.

The BT-500 V2 is the quickest and easiest solution to effortlessly connect with mobile devices in your studio over Bluetooth from as far away as over 100 meters.

NO MORE MINI JACKS...

The BT-500 v2.0 streams audio from your mobile device over Bluetooth and delivers a fully balanced, +22 dBu stereo output.

Employing latest generation audio specific Bluetooth technology, the best Codecs your devices can support and a state of the art Burr Brown based analog signal path, it solves the already classic, irritating problem of connecting your iOS or Android device to your studio setup.

To this day this has been solved using mini jack to XLRs adaptor cables, but the limitations of mobile devices' analog audio paths have become clearly apparent. Say goodbye to all those crappy minijack cables, faulty device connections and horrible internal ADC.

Listening to references on the iTunes Store, recordings sent by email, Spotify, You Tube, you name it, you do it every day, all the time. Nevertheless integration has been non convenient to say the least, until now.

SOUND QUALITY OVER BLUETOOTH? AAC & aptX...

The BT-500 v2.0 keeps things simple by recognising your device's best Codecs available to guarantee seamless integration offering AAC*, aptX** as well as the classic SBC.

Apple's iTunes Store and You Tube use AAC* as native so streaming from an iPhone or iPad will result in a lossless transmission, much better than an analog wired connection!!

Vast majority of Android devices have already adopted the aptX** codec, which is nearly lossless and the standard that wireless high quality headsets and sound bars are adopting.

With this updated version the BT-500 V2.0 now covers all of the best codecs available including: aptX(aptX LL & aptX HD), AAC and SBC, to ensure you stream audio at the highest quality possible. Whether you're using a mobile phone, a tablet, a watch phone or whatever you can be certain that the BT-500 V2.0 will detect the best option available for seamless integration. It really has never been easier to access your iOS or Android device when needed in the studio.

For a complete list of devices currently supporting aptX** please visit: <https://www.aptx.com/product-listing>

In case your device can't support neither AAC* nor aptX**, the BT-500 v2.0 will stream audio using the classic SBC codec.

BURR BROWN PEDIGREE IN THE ANALOG PATH...

The BT-500 v2.0 substitutes your mobile device's analog circuitry with a state of the art, fully differential Burr Brown balanced output stage which delivers a full 0 dBfs = +22 dBu output able to drive a load of 600 Ω . This allows direct level comparisons while mastering or mixing with Apple's iTunes Store or mobile stored reference mixes.

Providing fully balanced +22 dB stereo output on gold plated connectors with pristine Burr Brown conversion the BT-500 v2.0 guarantees you'll always be working with the best possible quality available.

At a surprisingly low street price, the BT-500 v2.0 strongly enters the "Studio Essentials" category and easily solves an already classic problem with a minimum investment.

(*) Heritage Audio is an official AAC licensee.

(**) Heritage Audio is an official aptX licensee.

GETTING STARTED

FRONT

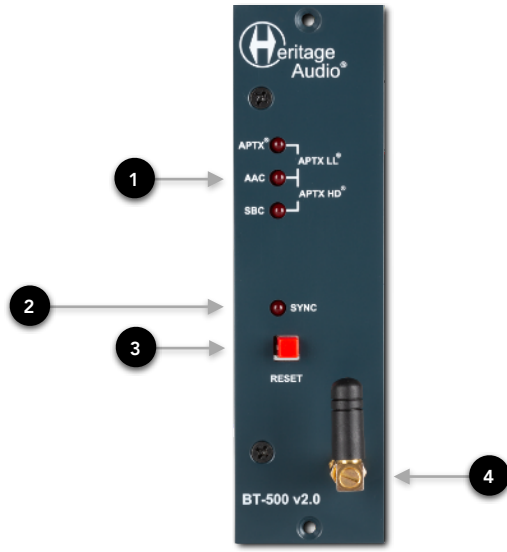

1	2	3	4
CODEC LEDs Indicate the Codec being used	SYNC LED is on when device is paired	RESET Resets any connection	ANTENNA Over 100 meter radius of coverage

REAR

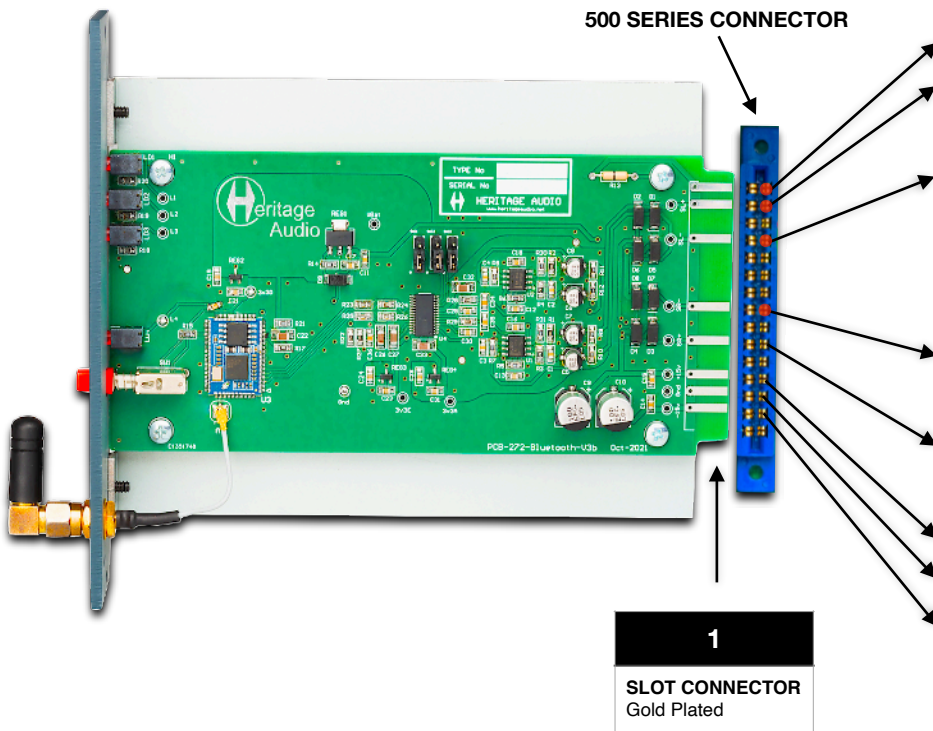

500 SERIES EDGE CONNECTOR PIN OUT	
TERMINAL	FUNCTION
1	CHASSIS GROUND
2	OUTPUT L + (4 LEVEL)
3	NOT USED
4	OUTPUT L - (4 LEVEL)
5	NOT USED
6	NOT USED
7	NOT USED
8	OUTPUT R + (4 LEVEL)
9	NOT USED
10	OUTPUT R - (4 LEVEL)
11	NOT USED
12	+16VCD
13	POWER SUPPLY COMMON
14	-16VCD
15	NOT USED

BLUETOOTH STEREO OUTPUT

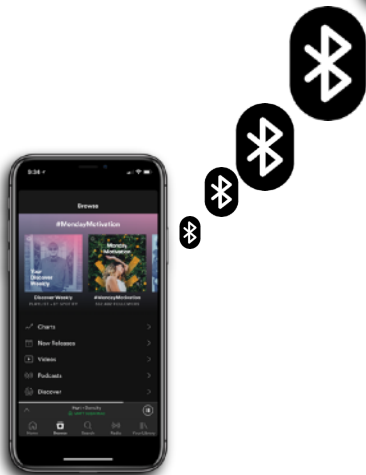

USB - COMPUTER



OUTPUT - L
(+22dBu BALANCED)
OUTPUT - R

LINE INPUTS
AUDIO INTERFACE

Included
Male/Male Adapter

BT-500 v2.0

SPECIFICATIONS



- Audio streaming module.
- 500 Series format.
- XLR Male to male adapter included.
- +22 dBu Balanced output.
- AAC Codec with iOS devices.
- aptX with legacy Android devices.
- Last generation aptX LL and aptX HD Codecs*.
- Classic SBC Codec also available.
- Dimensions (W x H x L): 38 mm x 135 mm x 150 mm (170 mm - With antenna).
- Weight: 270 g.

* Check for compatibility of your device. Qualcomm aptX, aptX LL and aptX HD are products of Qualcomm Technologies International, Ltd.



TROUBLE SHOOTING



PROBLEMS	SOLUTIONS
The BT-500 v2.0 doesn't seem to be receiving any audio.	Try pushing the 'SYNC' button as it will establish a new connection.
Still not receiving any audio.	Make sure the antenna is still attached.
Can't seem to make a connection with the BT-500 v2.0.	Make sure you have Bluetooth activated on your device.
Still can't seem to make a connection with the BT-500 v2.0.	Be sure to have selected the BT-500 v2.0 as a destination from your device.
And still can't seem to make a connection with the BT-500 v2.0. Am I too far away?	That is very unlikely as the BT-500 v2.0 has extremely wide coverage (over 100 meters). Try reconnecting by pushing the 'SYNC' button.

* For any further doubts or questions please get in contact with us at: support@heritageaudio.com



WARRANTY STATEMENT

LIMITED 2 YEAR WARRANTY

Heritage Audio BT-500 v2.0 is warranted by Heritage Audio SL to be free from defects in materials and workmanship for the period of 2 years to the original purchaser. In the event of such defects, the product will be repaired without charge or, at our option, replaced with a new one if delivered to Heritage Audio prepaid, together with a copy of the sales slip or other proof of purchase date. The warranty excludes problems due to normal wear, abuse, shipping damage or failure to use the product in accordance with the specifications.

Heritage Audio shall not be liable for damages based upon inconvenience, loss of use of the product, loss of time, interrupted operation or commercial loss or any other damages, whether incidental, consequential or otherwise.

This warranty is not transferable.

Heritage Audio and the Heritage Audio “H” logos are registered Trademarks owned and/or licensed by Heritage Audio.



REGISTRATION

Please visit our website: <https://heritageaudio.com/registration/>

RECALL SHEETS

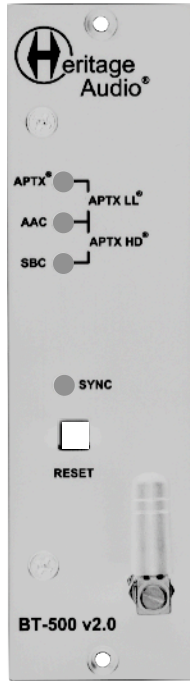

Session / Title: _____ Track: _____ Connected Equipment: _____

Date: _____ Codecs: _____ Notes: _____

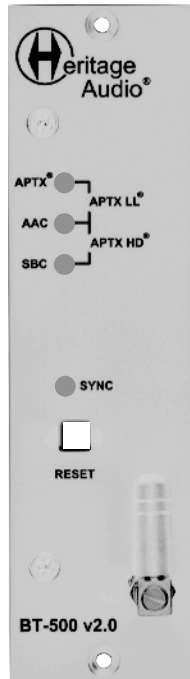

Session / Title: _____ Track: _____ Connected Equipment: _____

Date: _____ Codecs: _____ Notes: _____



www.heritageaudio.com

HERITAGE AUDIO. C/ Alfonso Gómez, 38, 3C. 28037 Madrid – Spain. Tel: +34 917 266 189

info@heritageaudio.com

