

# BRITSTRIP

CHANNEL STRIP WITH DIODE BRIDGE COMPRESSOR  
RACKMOUNT



## USER MANUAL



# INTRODUCTION

---

Thank you for choosing the **BRITSTRIP**. Heritage Audio is dedicated to bringing you ‘the sound of yesterday for tomorrow’. We specialize in capturing that unique, enticing sound that everybody has fallen in love with. For years engineers, producers and musicians have been yearning for that classic vibe. Usually the only option is to search for old, used original equipment that is almost always in a questionable state of operation. This brings with it a whole lot of other issues, making the experience less than desirable. Not to mention the very high prices asked for this equipment, which makes them virtually unobtainable for the great majority. Now it’s possible to obtain that same sound with a brand new piece that will give you all the problem-free, heavy-duty use you’ll need for years of music making history.

**Peter Rodriguez**  
CEO  
Heritage Audio - Madrid, Spain



© 2022 Heritage Audio S.L. is the sole owner of the copyright of all information and drawings contained in this manual which are not to be copied or reproduced by any means or disclosed in part or whole to any third party without written permission.

Heritage Audio reserves the right to alter specifications without notice. The information in this manual has been carefully checked and is believed to be accurate at the time of publication. However, no responsibility is taken by us for inaccuracies, errors or omissions nor any liability assumed for any loss or damage resulting either directly or indirectly from use of the information contained within it.

## TABLE OF CONTENTS

---

INTRODUCTION	2
CONTENTS	2
DESCRIPTION	3
GETTING STARTED	5
APPLICATIONS	7
SPECIFICATIONS	11
SIGNAL FLOW	12
TROUBLE SHOOTING	13
WARRANTY STATEMENT	14
REGISTRATION	14
RECALL SHEETS	15



## DESCRIPTION

---

### BRITSTRIP

The Heritage Audio **BRITSTRIP** is the culmination of over 50 years of high end analog design all bundled up in a single easily navigated rack unit. The **BRITSTRIP** nails the sound of yesterday's iconic recordings for today's demanding musicians, engineers and producers.

Combining a real-deal 73 mic preamplifier, an expanded 73 equalizer, a discrete Class A D.I., and the infamous diode bridge compressor from the Heritage Audio Successor, the BritStrip will cover all the bases. The closest equivalent of the BritStrip would be chaining together a 73 JR II, 73 EQ JR and mono Successor — a \$3000 value pack in itself, with added routing flexibility.

The **BRITSTRIP** proudly starts off with the same preamp found in our well-loved 73 JR, with a new custom input transformer co-designed by Carnhill and exclusively made for Heritage Audio in their St Ives factory. The preamp also features a custom designed Carnhill St Ives output transformer to complete its all discrete, Class A, 3-gain stage design. The preamp features a hearty 80 dB of gain, a 20 dB pad, phase reversal and an impedance switch for switching between 1200  $\Omega$  and 300  $\Omega$  at input.

The D.I. is also taken from the highly acclaimed design found in the Heritage Audio 73 JR, an all-discrete Class A JFET circuit in front of the microphone transformer, giving you all of the color and weight you could ask for. Being in front of the MIC transformer gives you lots of creative flexibility to push the signal as much as you see appropriate.

The D.I. also includes a passive thru output to feed a separate amplifier simultaneously while also passing the signal through the rest of the unit, the EQ and compressor.

The **BRITSTRIP** EQ features 3 Vinkor pot core inductors in the mid-band and high-pass filter sections. The impact of an inductor circuit is hard to believe with extreme boosts being exceptionally musical with minimal to no artefacts.

The mid-band is great for sculpting fat and punchy snares, kicks, guitars, vocals, you name it! No need to be subtle like you would with most EQs, the **BRITSTRIP** doesn't sound phasey or lose headroom in extreme settings.

The inductor-based low-pass filter, directly taken from the 73 design, lets you control out of range low end, without affecting the quality of your desired frequencies.

The high and low shelves have been extended to include a bell mode, making them even more versatile than ever before.

The equalizer section consists of high and low shelves in a Baxandall arrangement, with enhanced PEAK response, a dual inductor-based mid band with dual Q switch, and an inductor based passive high pass filter. Essentially an enhanced 73 equalizer section.

Frequencies are as follows:

- **High shelf:** 10, 12 and 16 kHz, PEAK or SHELF curve response.
- **Mid band:** 360, 700, 1600, 3200, 4800 or 7200 Hz. Hi or Lo Q.
- **Low shelf:** 60, 110 or 220 Hz, PEAK or SHELF curve response.
- **High Pass Filter:** 50, 80, 160 or 300 Hz, 18 dB/oct.

The equalizing section is followed by the Output control, to allow for perfect gain staging after equalizing.



The included diode bridge bus compressor needs little introduction, as it's the same compressor found in the multi award-nominated Heritage Audio Successor. Diode bridge compression, a 60 year old patent, took on a whole new life with the expanded features and incredibly fast Attack & Release times of the Successor. Unlike vintage diode bridge designs, the compressor in the BRITSTRIP has a range of release times that goes from ultra-fast, FET like values, to very slow, VCA like gentle timings, making this unit arguably one of the most versatile tracking compressors to date.

A blend circuit with ON/OFF function makes parallel compression an easy option and something sure to be used frequently as there is immediate access to this feature. Providing you with plenty of control, the BRITSTRIP can give instruments that "record-ready" sound, giving them a finished "real-time feel" as they are being recorded.

To make things even more versatile, a complex side chain filter has been implemented, departing from the traditional high pass one. This provides plenty of flexibility, with 5 frequency options and an external side chain input for even more precise control. And if that weren't enough, 2 BRITSTRIPs can have their compressors linked for the ultimate stereo tracking solution.

## COMPRESSOR CONTROLS:

- DYN IN: Activates the compression section.
- DYN PRE EQ: Places the compression section ahead of the EQ.
- GAIN MAKEUP: Recovers gain from 0 to 20 dB.
- RATIO: 1.5:1, 2:1, 4:1, 6:1, 10:1.
- THRESHOLD: From -20 to +20 dBu.
- RELEASE: 50, 100, 200, 400 ms and AUTO.
- ATTACK FAST: Activates the faster attack.
- SIDECHAIN FILTER: OFF, 50 and 100 High Pass Filter, 800 and 3k Peak, and 5k High Cut Filter.
- BLEND: From fully DRY to fully WET.
- BLEND ON: Activates the blend circuit.
- VU/GR: Meter activity either Gain reduction or output level.

The BRITSTRIP allows for flexible compression and equalizer routing. EQ'ing pre-compression makes the compression detector more sensitive to the boosted frequencies and less sensitive to those cut. Inversely, EQ'ing post compression makes the detector circuit insensitive to the EQ settings allowing you to mould your signals even more.



# GETTING STARTED

## FRONT

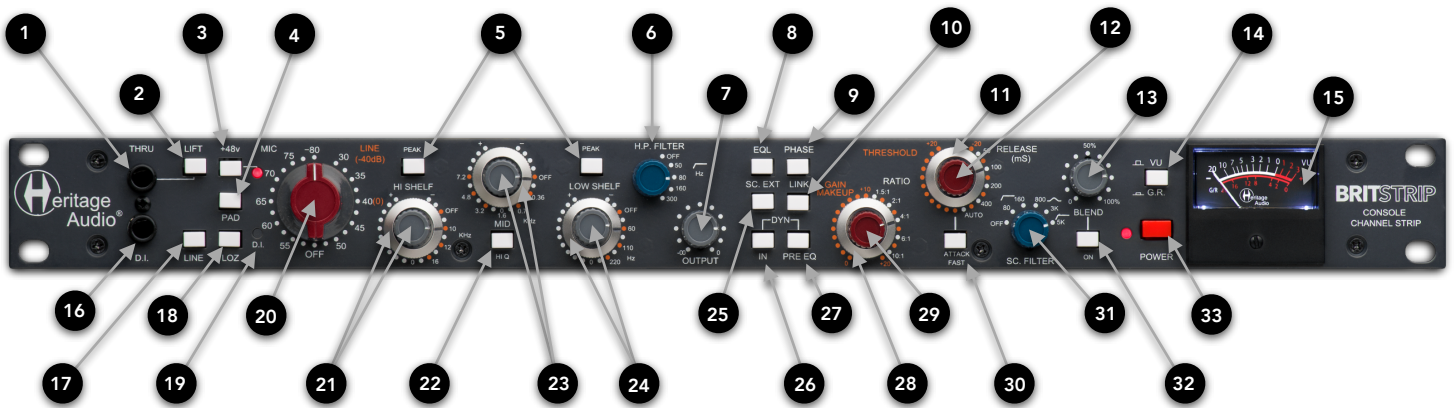

<b>1</b>	<b>2</b>	<b>3</b>	<b>4</b>	<b>5</b>
<b>THRU</b> To send the D.I. signal to an AMP	<b>LIFT</b> Lifts the ground from the THRU input	<b>PHANTOM POWER SWITCH</b> Activates 48 V, with indicating red light	<b>MIC PAD BUTTON</b> 20 dB Reduction Ahead of Input Transformer	<b>PEAK</b> Switches the SHELF response curve to PEAK
<b>6</b>	<b>7</b>	<b>8</b>	<b>9</b>	<b>10</b>
<b>H.P. FILTER</b> -3 dB at 4 Selectable High Pass Frequencies	<b>OUTPUT</b> Attenuates the EQ output signal	<b>EQL</b> Activates the EQ section	<b>PHASE</b> Inverts the signal 180 degrees	<b>LINK</b> Sends the DC control signal to the RCA connector
<b>11</b>	<b>12</b>	<b>13</b>	<b>14</b>	<b>15</b>
<b>RELEASE</b> 4 Selectable Fixed Options and AUTO	<b>THRESHOLD</b> Fully variable from +20 dBu to -20 dBu	<b>BLEND</b> Parallel Compression Continually variable from 100% WET to 100 % DRY	<b>VU/GR</b> Switches the meter from tracking gain reduction to output level	<b>METER</b> Measures Gain reduction in dB or Output level.
<b>16</b>	<b>17</b>	<b>18</b>	<b>19</b>	<b>20</b>
<b>D.I. INPUT</b> High Impedance Class A JFET	<b>LINE</b> Swaps the unit into LINE mode	<b>LOZ</b> Switches the input impedance from 1200 Ω to 300Ω in MIC mode	<b>D.I. INDICATOR</b> Lights up green when jack is inserted	<b>INPUT GAIN SWITCH</b> Sets the input gain in 5dB increments from 30 to 80 dB in MIC mode, 40 dB less in LINE mode
<b>21</b>	<b>22</b>	<b>23</b>	<b>24</b>	<b>25</b>
<b>HI SHELF</b> Adjusts the Boost/Cut (Inside) and Selects the Frequency (Outside)	<b>HI Q</b> Sets a higher Q for the mid band	<b>MID SHELF</b> Adjusts the Boost/Cut (Inside) and Selects the Frequency (Outside)	<b>LOW SHELF</b> Adjusts the Boost/Cut (Inside) and Selects the Frequency (Outside)	<b>SC. EXT</b> Takes the AC control signal from the Sidechain In connector
<b>26</b>	<b>27</b>	<b>28</b>	<b>29</b>	<b>30</b>
<b>DYN IN</b> Activates the Dynamics section	<b>DYN PRE EQ</b> Places the dynamics section ahead of the equalizer	<b>RATIO</b> From 1.5:1 to 10:1 on a 5 position rotary switch	<b>GAIN MAKEUP</b> Allows for restoring the gain loss up to 20dB	<b>ATTACK FAST</b> Switches the attack to the fastest setting
<b>31</b>	<b>32</b>	<b>33</b>		
<b>SC. FILTER</b> 4 Selectable Frequencies for the Side Chain of the Dynamics	<b>BLEND ON</b> Switch to activate the BLEND	<b>POWER</b> Turns on the unit		

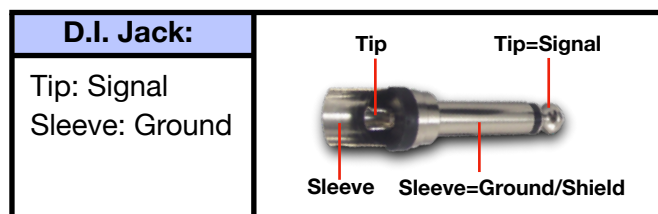

# GETTING STARTED

## REAR

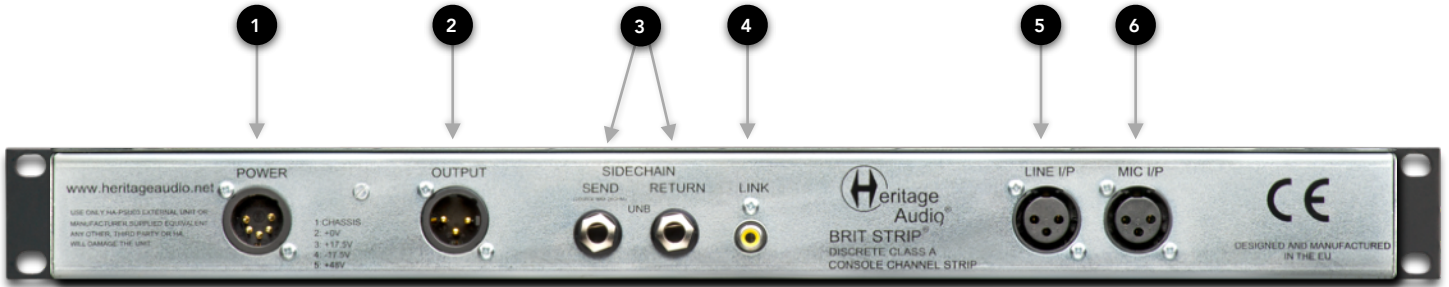

1	2	3	4
<b>POWER INPUT</b> To Be Connected to the HA PSU03 Power Supply	<b>LINE OUTPUT</b> Gold Plated Male XLR Connector	<b>SIDECCHAIN</b> Unbalanced Send & Return 1/4 Jack	<b>LINK</b> Female RCA Connector to pair to units for stereo use
5	6		
<b>LINE INPUT</b> Gold Plated Female XLR Connector	<b>MIC INPUT</b> Gold Plated Female XLR Connector		

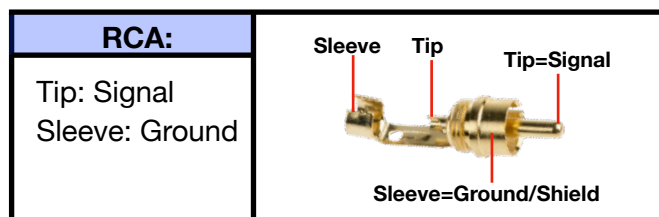
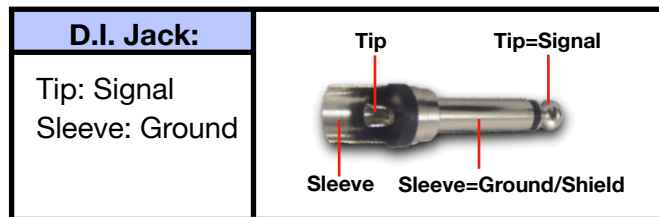
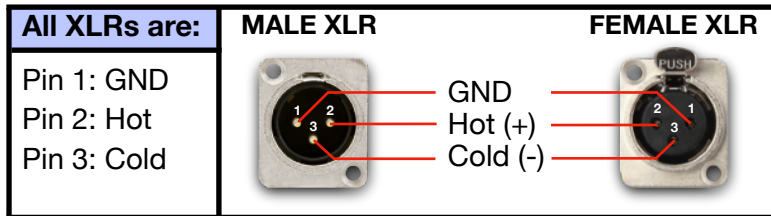

# APPLICATIONS

## MIC

CONDENSER MIC

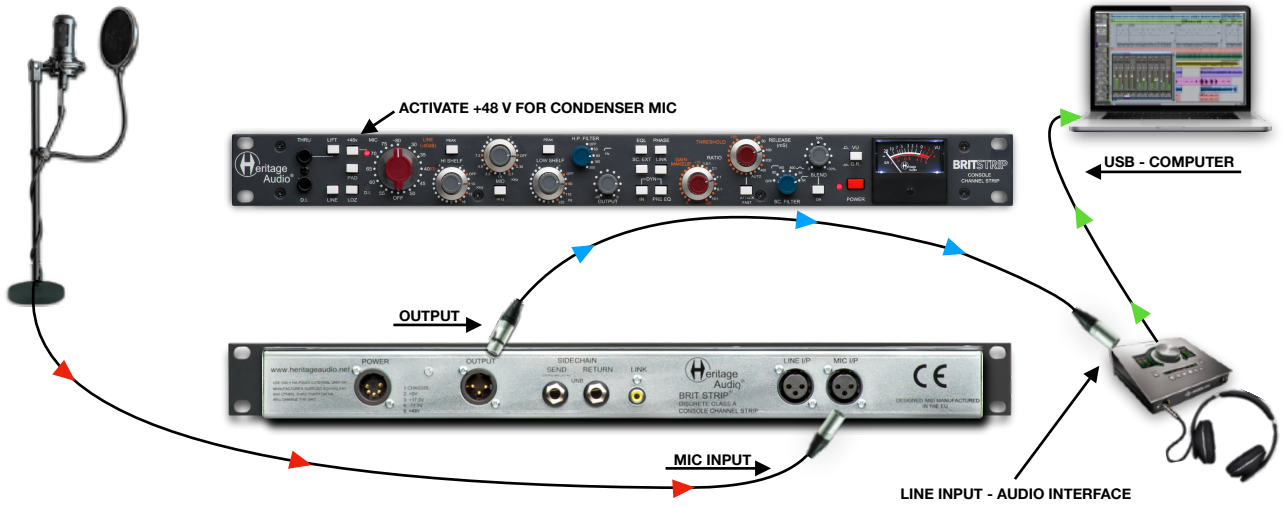

## D.I.

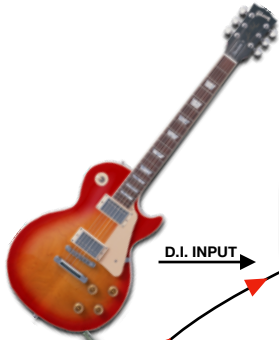

D.I. INPUT

GUITAR FX PEDAL

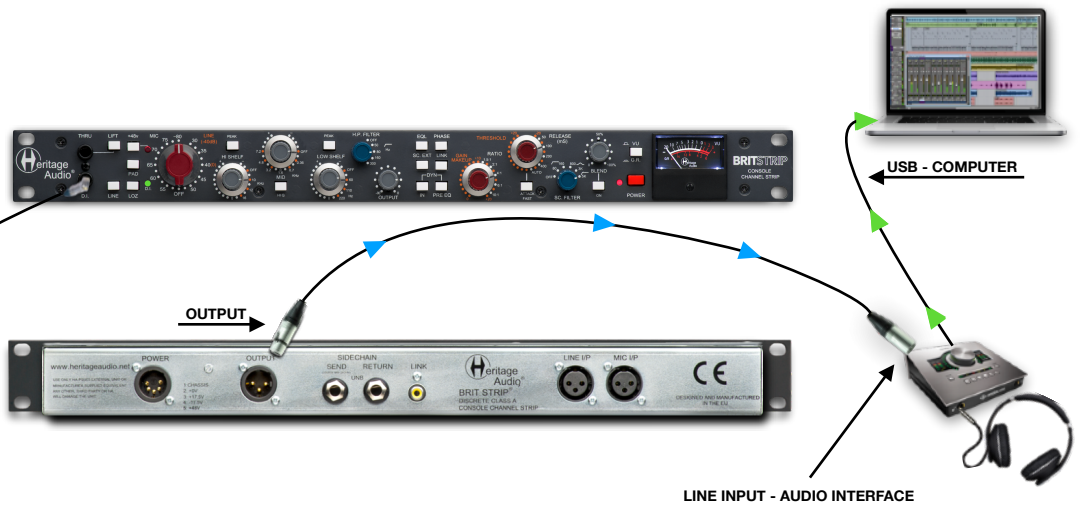

## LINE

LINE OUTPUT - KEYBOARD



ACTIVATE LINE SWITCH

OUTPUT

LINE INPUT

LINE INPUT - AUDIO INTERFACE



USB - COMPUTER

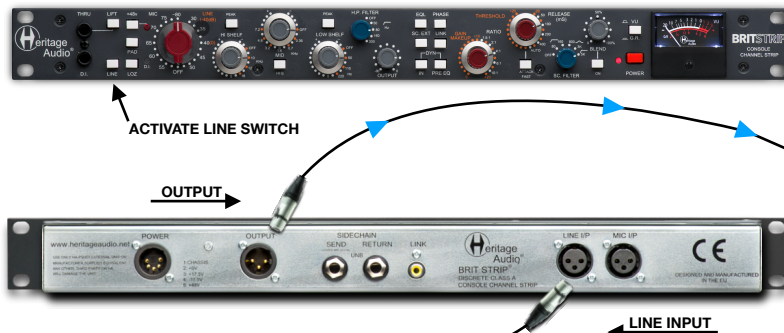

# DRUM RECORDING

1 - MIC INPUT	KICK
2 - MIC INPUT	SNARE ↑
3 - MIC INPUT	SNARE ↓
4 - MIC INPUT	HI HAT
5 - MIC INPUT	TOM 1
6 - MIC INPUT	TOM 2
7 - MIC INPUT	OH - L
8 - MIC INPUT	OH - R

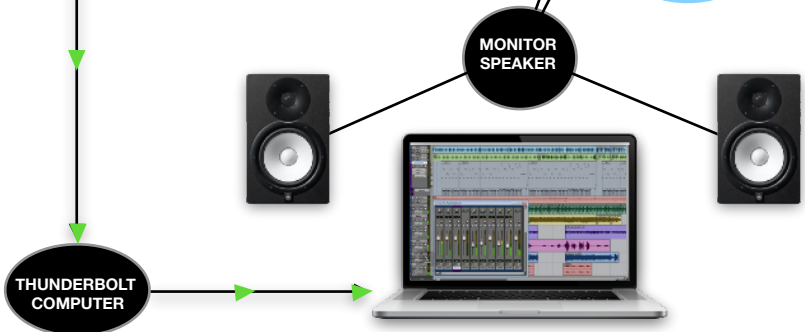



## MIXING CHANNEL INSERT

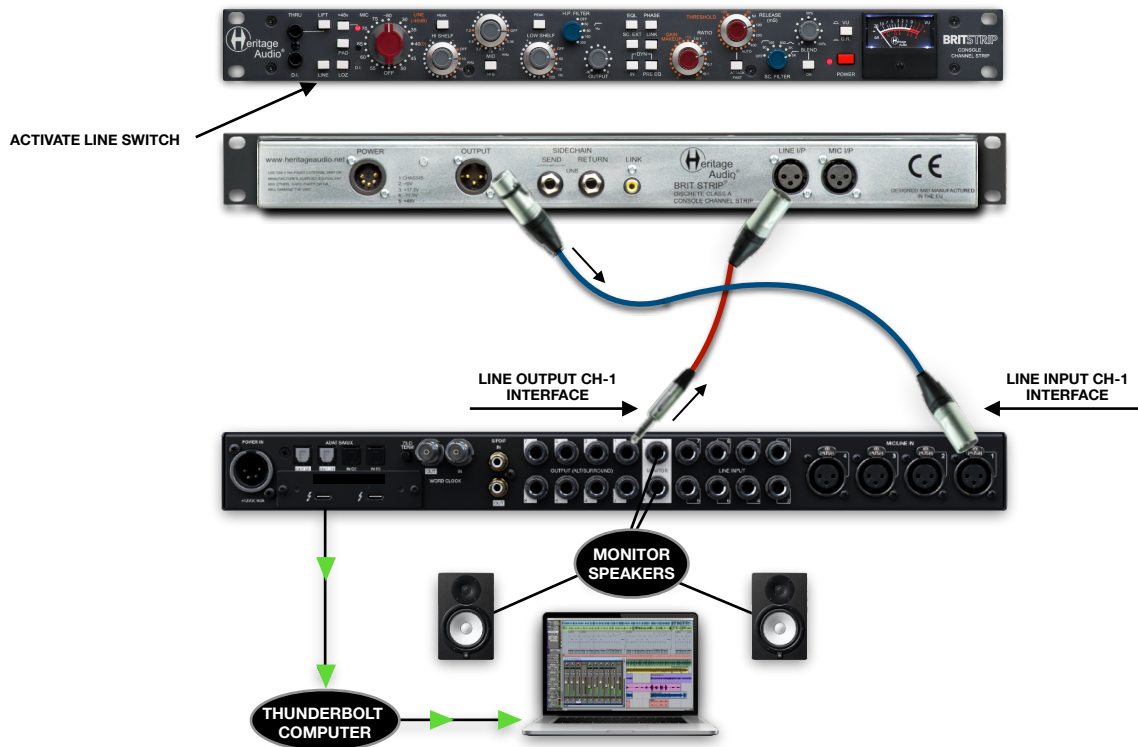

## MIXING EXT SIDECHAIN

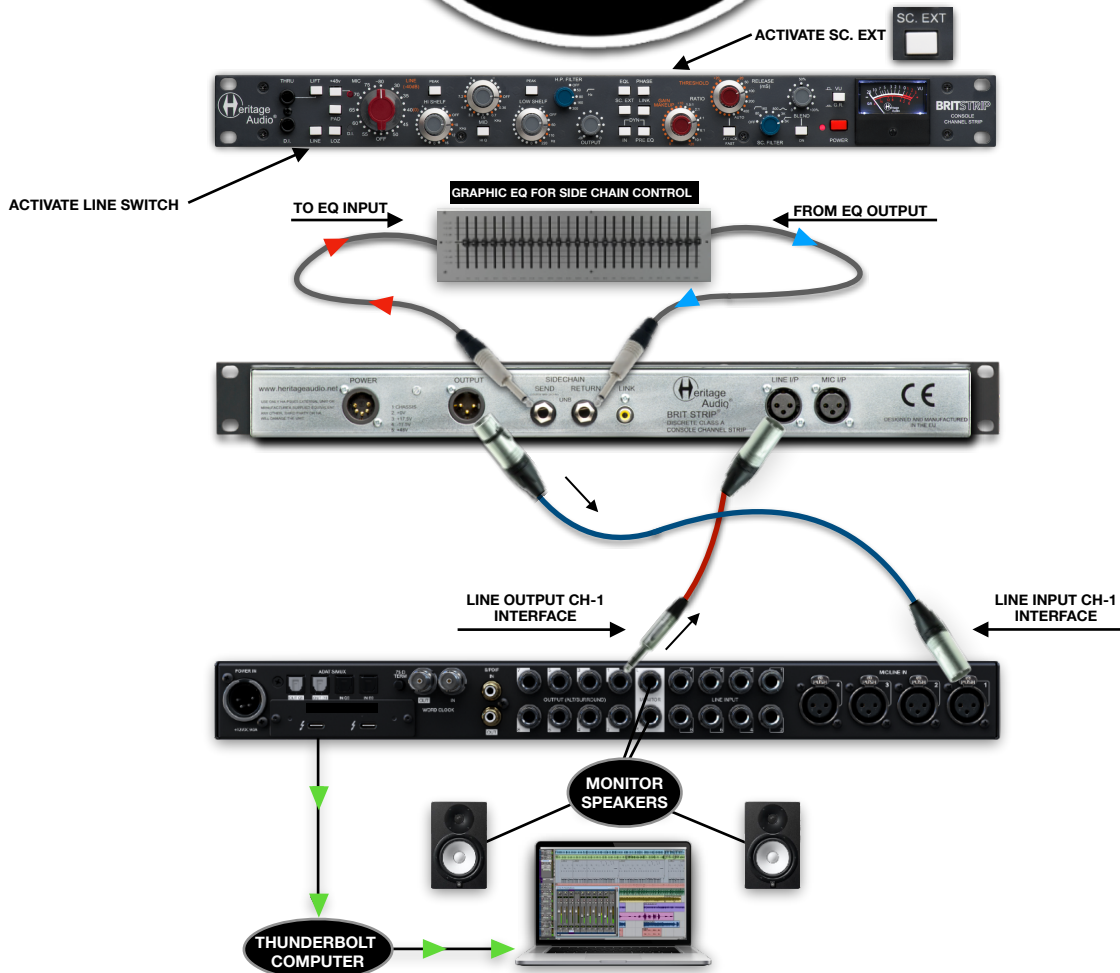

# MIXING STEREO LINK

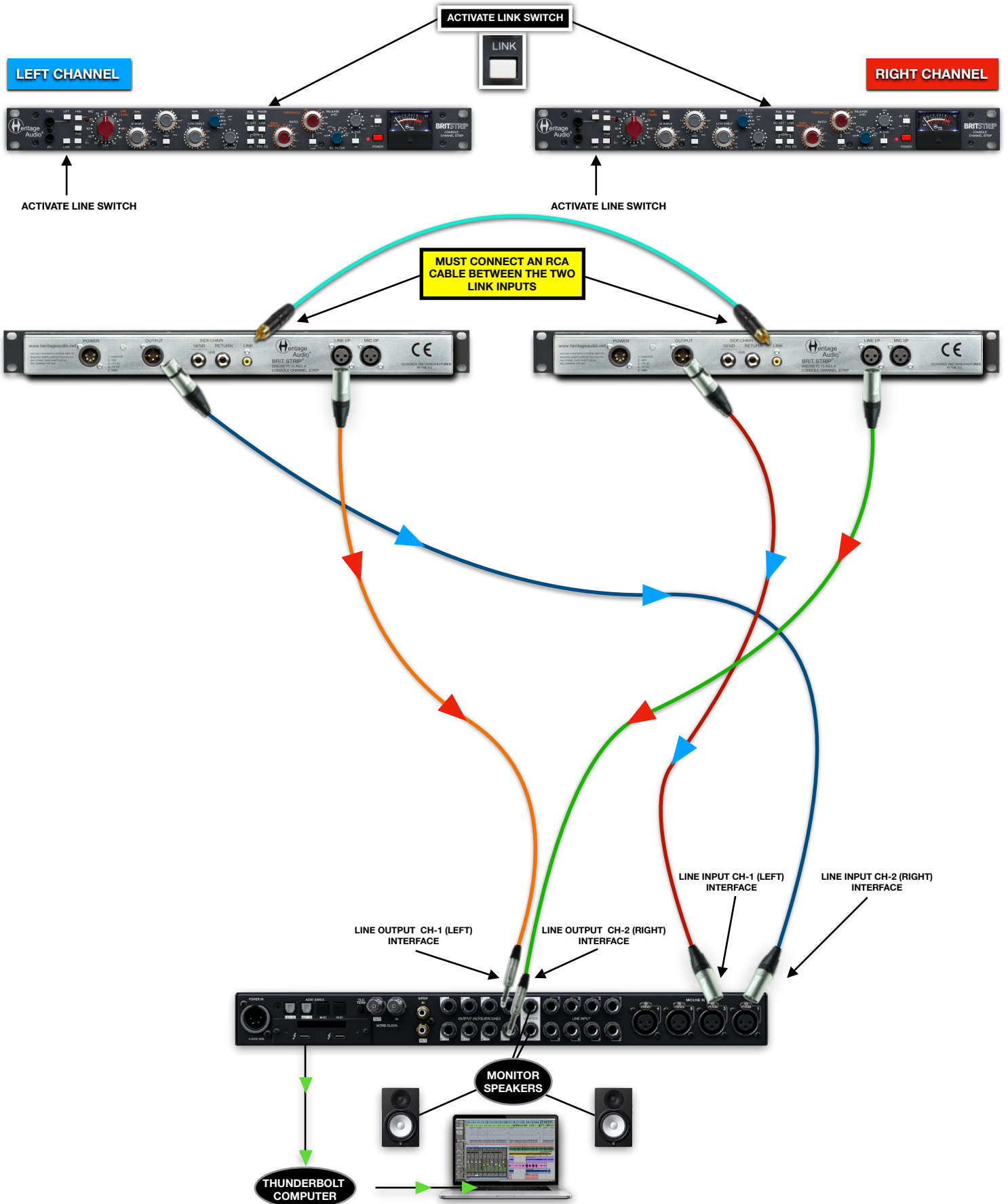

# SPECIFICATIONS

---



---

## Mic Amp Section

---

- Carnhill based, transformer coupled balanced inputs and outputs for added character and vintage vibe.
- 73 style class A output stages bring the desired 73 sound to your mix or drum buses.
- **Microphone input impedance:** HI=1200  $\Omega$  minimum, LO=300  $\Omega$  minimum.
- **Line input impedance:** 10 K $\Omega$  bridging, transformer balanced and floating.
- **DI input impedance:** Greater than 2 M $\Omega$ , unbalanced.
- **Output impedance:** Less than 75  $\Omega$ , transformer balanced and floating, to drive a load of 600  $\Omega$  (factory terminated).
- **Maximum output:** Greater than +26 dBu into 600  $\Omega$ .
- **THD:** Less than 0,025 % at 1 kHz, less than 0,05 % at 100 Hz.
- **Frequency response:** 20 Hz ( +0,3 dB ) to 20 kHz (-0,2 dB).
- **Maximum gain:** Slightly greater than 80 dB.
- **Noise:** Less than -125 dBu EIN.

---

## Technical Specifications

---

- **Maximum input level:** Over +22 dBu.
- **Maximum output level:** Over +25,5 dBu into 600  $\Omega$ .
- **MIC Input EIN:** -125 dBu @ 60 dB.
- **MIC Input impedance:** 300  $\Omega$  or 1200  $\Omega$  selectable.
- **DI Input impedance:** Greater than 2 M $\Omega$ .
- **THD+N (50Hz- 20kHz):** DYNAMIC IN not engaged, less than 0,07 % at +20 dBu.
- **Frequency response:** +- 0,5 dB, 15 Hz- 30 kHz.
- **Line Input impedance:** 10 K $\Omega$ , transformer balanced and floating.
- **Output impedance:** Less than 75  $\Omega$ , transformer balanced and floating, Class A driven.

---

## Dimensions

---

- **Dimensions BRITSTRIP (W x H x L):** 482 mm x 44 mm (1 Rack unit) x 184 mm.

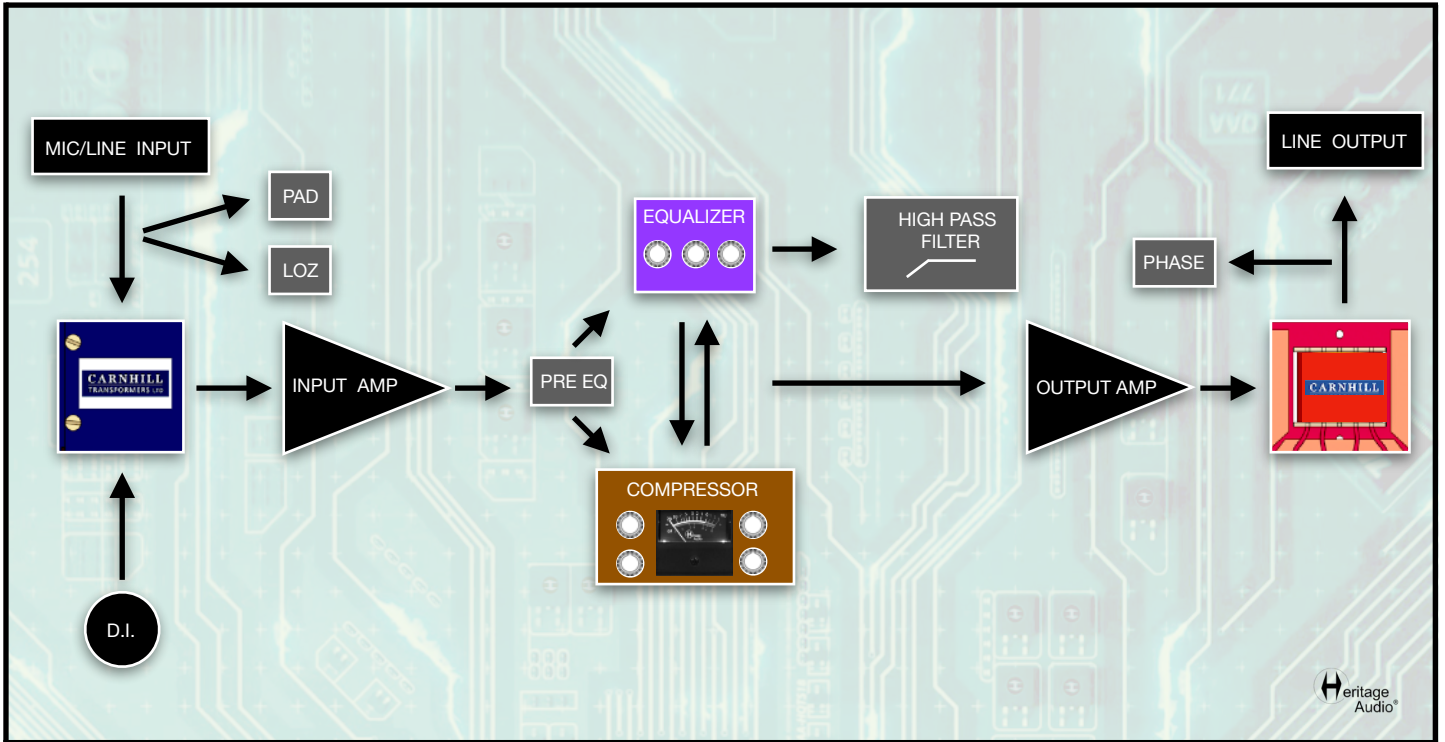

## TROUBLE SHOOTING



PROBLEMS	SOLUTIONS
There doesn't seem to be any power feeding the <b>BRITSTRIP</b> .	Make sure the HA-PSU03 power supply has been connected.
There is no signal from my MIC.	Make sure the LINE button is not pressed.
There is no signal from my D.I.	Make sure the LINE button is not pressed.
There is still no signal from my D.I. even without the LINE button pushed.	Push the LINE button several times repeatedly just in case it got stuck or there was a bad contact.
There is no signal from my MIC.	Make sure the 48 V button is pressed.
There is still no signal from the <b>BRITSTRIP</b> .	Make sure the GAIN MAKEUP is not fully turned down.
There is a ground like noise on my amp.	Try pushing the 'LIFT' button to see if it helps.
While adjusting the GAIN my signal suddenly disappears.	Make sure you are not simply in the 'OFF' position, between the two gain stages.
There is just way too much compression occurring.	Try adjusting the BLEND knob to make the effect less severe.
The low end seems to be overpowering the compressor.	Adjust the SC FILTER so the compressor is not so sensitive to lower frequencies. If necessary, insert a graphic EQ for more control.
I can not get my two <b>BRITSTRIPS</b> to link together.	Have you connected the necessary cable between the two to make the link?

\* For any further doubts or questions please get in contact with us at: [support@heritageaudio.com](mailto:support@heritageaudio.com)

## WARRANTY STATEMENT

---

### LIMITED 2 YEAR WARRANTY

Heritage Audio **BRITSTRIP** is warranted by Heritage Audio SL to be free from defects in materials and workmanship for the period of 2 years to the original purchaser. In the event of such defects, the product will be repaired without charge or, at our option, replaced with a new one if delivered to Heritage Audio prepaid, together with a copy of the sales slip or other proof of purchase date. The warranty excludes problems due to normal wear, abuse, shipping damage or failure to use the product in accordance with the specifications.

Heritage Audio shall not be liable for damages based upon inconvenience, loss of use of the product, loss of time, interrupted operation or commercial loss or any other damages, whether incidental, consequential or otherwise.

This warranty is not transferable.

Heritage Audio and the Heritage Audio “H” logos are registered Trademarks owned and/or licensed by Heritage Audio.



## REGISTRATION

---

Please visit our website: <https://heritageaudio.com/registration/>

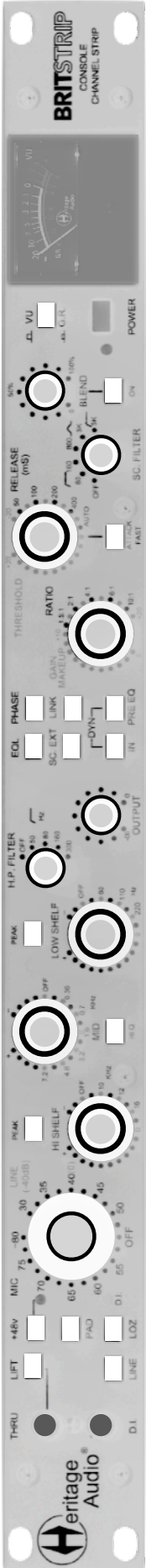

Session / Title: \_\_\_\_\_ Track: \_\_\_\_\_ Connected Equipment: \_\_\_\_\_

Switch ON   
 Switch OFF

Date: \_\_\_\_\_ Instrument: \_\_\_\_\_ Notes: \_\_\_\_\_

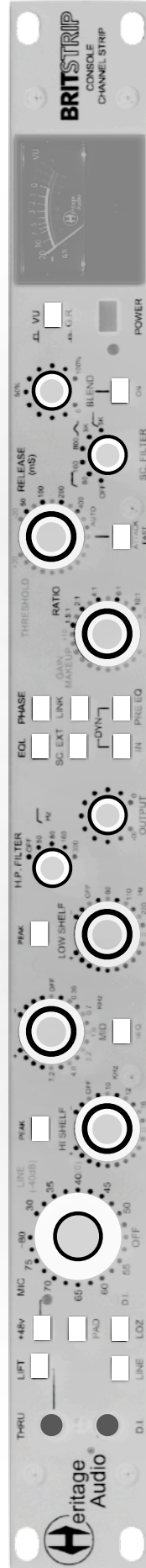

Session / Title: \_\_\_\_\_ Track: \_\_\_\_\_ Connected Equipment: \_\_\_\_\_

Switch ON   
 Switch OFF

Date: \_\_\_\_\_ Instrument: \_\_\_\_\_ Notes: \_\_\_\_\_



[www.heritageaudio.com](http://www.heritageaudio.com)

**HERITAGE AUDIO.** C/ Alfonso Gómez, 38, 3C. 28037 Madrid – Spain. Tel: +34 917 266 189

[info@heritageaudio.com](mailto:info@heritageaudio.com)

